



# IJEAST

INTERNATIONAL JOURNAL  
OF ENGINEERING APPLIED SCIENCE  
AND TECHNOLOGY



**VOLUME : 5    ISSUE : 12    Print / Issue Publication Date: 13-Jul-2021**



**ISSN : 2455-2143**



**DOI : 10.33564/IJEAST.2021.v05i12.016**

Indexed In



[WWW.IJEAST.COM](http://WWW.IJEAST.COM)

[editor@ijeast.com](mailto:editor@ijeast.com)

# THE MAGNETIC ELECTRICITY GENERATOR AND ITS APPLICATION IN WIND TURBINES

P.R.Gavali

Prof. Department of Computer Science and Information Technology,  
Rajarambapu Institute of Technology, Islampur, India

Harshad Kumbhar, Sagar Birajadar

Department of Computer Science and Information Technology,  
Rajarambapu Institute of Technology, Islampur, India

**A B S T R A C T** - A permanent magnet synchronous generator (PMSG) is a device that converts mechanical energy to electrical energy. Permanent magnet generators generate electricity with the inside magnets that can be used to power other electric devices. A PMSG is a generator, where the excitation field is provided by a permanent magnet instead of a winding coil. In this generator/device the rotor windings have been replaced with permanent magnets. Its rotor is consisting of the permanent that generates a field for excitation and replaces the external supply source for the generator. In most of power generation plants, the synchronous generator is used. Now days synchronous generator is used in all types of turbines for e.g. steam turbine, gas turbine and hydro turbine etc. The Permanent Magnet Generator uses the magnetic field generated by a permanent magnet to convert mechanical energy into electrical power. It can be able to generate an AC current, with which it can able to power the whole engine and charge the battery. This study helps to understand the working and application of Permanent Magnet Generator in a windmill turbine.

**Keywords** - Windmill system (WS), Permanent magnet synchronous generator (PMSG), Wind turbine (WT), Excitation Circuit (EC).

## I. INTRODUCTION

The use of permanent magnet synchronous machine is an interesting topic for study. In the continuously growing world the demand for energy is ever growing. The synchronous machines with permanent magnets are rising as reliable equipment for energy generation. With globally increasing demand of energy and by considering the environmental impact and pollution by current time energy generation techniques, the need of methods which uses nonconventional renewable resources for energy production which produce minimum or no impact and pollution of environment is huge.

The wind, water and steam are used to provide mechanical or kinetic energy to the turbines. In a wind system the windmill turbine will continue to convert kinetic energy to electric energy despite of unsteady, irregular and constantly changing flow of wind.

In the wind system, there are two existing primary techniques for energy production. First one is a permanent magnet synchronous generator (PMSG) and second is doubly fed induction generator (DFIG). The waveform of the voltage generated in PMSG is synchronized with rotating generator. A multiple turbine driven PMSG is used in wind conversion system. A distorted waveform and voltage have produced in the system when using nonlinear devices. The injected harmonics have several impacts on utilities grids and loads connected to the system. The harmonic active filters are used to beat the power quality issues. The parallel active power filters are used to decrease the cost and increase the reliability of the wind system. By using these the total harmonic distortion is minimized to least which increases the quality of the wind system

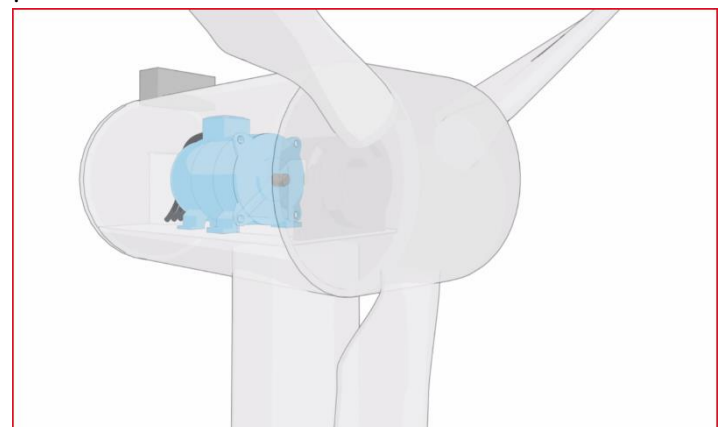

Fig (1) Overview of PMSG in wind turbine

## II. LITERATURE REVIEW

The topic of synchronous machines and use of permanent magnets in synchronous generator has been studied for a long time. Lalit Kumar Gautam and Mugdha, Mishra have already covered the point of wind energy conversion by using PMSG, here there is no requirement of gearbox in the system [1]. The studies for systematic control of permanent magnet synchronous machines (PMSM) and DC motor without brushes has been done by Sandra Eriksson[2]. Designs for generators of wind power, hydro power and power in the form of waves has been studied [2]. Designs for PMSG for a wind turbine with vertical axis has also been studied. The basic development in power electronics and conversion of electric power is done by F. Bladbjerg, Z. Chen, R. Teodorescu.F.Iov they also studied the wind turbine configurations both electrically and aerodynamically[3].For instance, the electrical efficiency of PMSGs is higher than the synchronous-generators (SGs) in the moderate-size power marine diesel gen-sets[4]. The current-vector of an interior type PMSG optimizes the operation at variable wind-velocity, which needs control of six active switches [5] The variable-speed operation of the WECS is essential for extracting maximum wind power. A modern control based tracking of power or torque helps to achieve better utilization of wind-energy [6]. To acquire required shaft speed control strategies are developed based on wind-velocity. high cost and reduced reliability involved in this scheme for a small scale WECS. A Maximum-Power-Extraction Algorithm (MPEA) is proposed for a grid-connected PMSG based WECS and it is feasible to implement in practical without any mechanical sensors for WECS via a PMSG [7]. A high value for gear ratio is chosen, the machine rotates slowly and the rated wind speed is at a low wind speed and then power coefficient drops for high wind speeds [8]. An MPPT control for a PMSG-based grid-tied wind generation system [9]. Voltage transient analysis of a PMSG wind power system using controller-hardware-in-the loops [10]. Realization and control of a wind turbine connected to the grid by using PMSG [11].Control of PMSG based variable speed wind-battery hybrid system in an isolated network[12].Wind Energy Conversion System Connected With the Grid by Using Permanent Magnet Synchronous Generator (PMSG)[13].

## III. METHODOLOGY

The following fig (1) shows the basic structure of PMSG which is used in the wind turbines. Torque generated by the turbines by using kinetic energy in the wind power. The torque generated is then transferred to the rotor of the generator through the generator shaft.

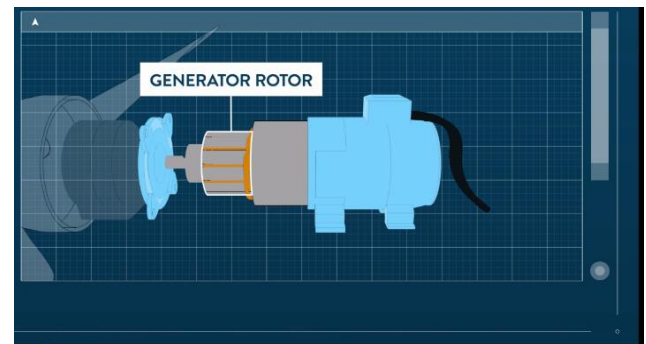

Fig(2) Rotor in Generator

An electrical torque is produced by the generator and the mechanical torque produced from the wind turbine and electrical torque generated from the PMSG determines the situations like acceleration and deceleration of mechanical system or the system remains a constant speed[14]. The current produced from the PMSG is rectified by a three-phase inverter which is connected to the generator to charge a DC-link  $U_{dc}$  capacitor [15]. A second three-phase inverter is fed by the DC-link  $U_{dc}$ , this inverter is connected to the utility grid through an angle, the rotor and the inverter output are accepted to compare with the grid side data.

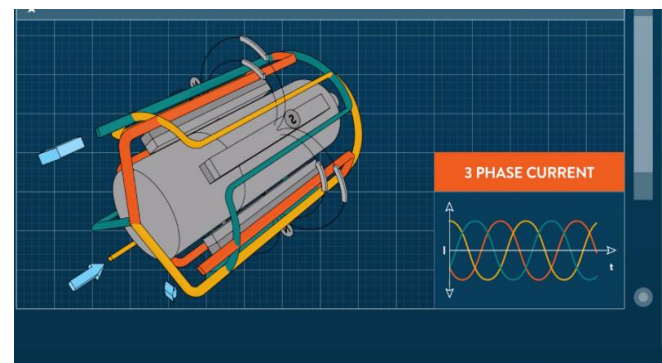

Fig(3) 3-Phase Current Generation by 120° placed armature coils.

A digital signal processing system is used to achieve the correct signals for the best control on the components. The main intent is to synchronize the utility grid and to export power to it [14].

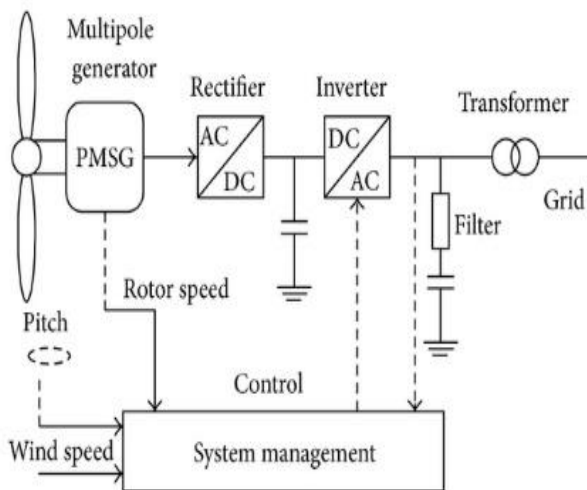

Fig(4) Structural Architecture of WCS

The conversion of kinetic energy of wind to mechanical work is done by the wind turbine. "On the basis of relationship for the calculations, it is possible to express the volume  $P_m$  of the aerodynamic wind turbine." [16-17-18]

$$P_m = 0.5 \cdot \rho \cdot A \cdot v^3 \cdot C_p(\lambda, \beta) \quad (1)$$

Here  $\rho$  is the air density and  $A=3.14 \cdot R^2$  is the blade swept of the turbine,  $V$ = velocity of wind

And is the  $C_p(\lambda, \beta)$  coefficient of power. The power coefficient represents the relationship between pitch and tip speed. The power coefficient is given as:  
 With

$$C_p(\lambda, \beta) = 0.22 \left( \frac{116}{\gamma} - 0.4 \cdot \beta - 5 \right) \cdot \exp\left(-\frac{12.5}{\gamma}\right) \quad (2)$$

$$\frac{1}{\gamma} = \frac{1}{\lambda + 0.089} - \frac{0.035}{\beta^3 + 1} \quad (3)$$

The tip speed lambda is shown as:

$$\lambda = \frac{R \cdot \omega}{v} \quad (4)$$

Where lambda is the relationship between rotor speed and

wind velocity,  $\omega$  is the angular velocity of the blades and  $R$  is the radius of the rotor.

On the basis of rotational motion performance, the value of the torque  $T_m$  which is acting on the generator shaft can be shown follows:

$$T_m = \frac{P_m}{\omega} \quad (5)$$

According to above formulas it makes clear that simultaneous values of performance and mechanically generated torque, on large scale are wind speed dependent.

While pitch angle is kept constant the rotational speed is a function where the energy captured by the blades of the turbine gain maximum output at a specific speed of rotation. This concludes that the tip speed should be kept at  $\lambda_{opt}$  for maximum energy.

The PMSG is modelled completely in dq-coordinates. This conclude that the AC-states are absent in this model. Following figure shows that the PMSG is modelled with DC voltage and the currents are in fixed rotor, rotating coordinate system. The d-axis and the q-axis equation are defined in (1-2-3).

$$\frac{di_{sd}}{dt} = -\frac{R_{sa}}{L_{sd}} i_{sd} + \omega_s \frac{L_{sq}}{L_{sd}} i_{sq} + \frac{1}{L_{sd}} u_{sd} \quad (6)$$

$$\frac{di_{sq}}{dt} = -\frac{R_{sa}}{L_{sq}} i_{sq} - \omega_s \left( \frac{L_{sd}}{L_{sq}} i_{sd} + \frac{1}{L_{sq}} \psi_p \right) + \frac{1}{L_{sq}} u_{sq}$$

The electromagnetic torque in the rotor is given by the following equation:

$$T_e = 1.5 \frac{P}{2} \left[ \psi_p i_{sq} + i_{sd} i_{sq} (L_{sd} - L_{sq}) \right] \quad (7)$$

The electromagnetic torque in the rotor is given by the following equation:



$$T_e = 1.5 \frac{P}{2} \left[ \Psi_p i_{sq} + i_{sd} i_{sq} (L_{sd} - L_{sq}) \right] \quad (7)$$

Where  
the

symbols used are:

1)  $u_{sd}, u_{sq}$  = The d-axis and q-axis voltages respective  
stator resistances.

$i_{sd}, i_{sq}$  = The currents along d-axis and q-axis.

2)  $\omega_s$  = The angular frequency of generator.

$\Psi_p$  = Permanent flux.

$L_{sd}, L_{sq}$  = Inductance of generator along respective axis

3)  $R_{sa}$  = Stator resistance.

$P$  = Number of poles

*Advantages of PM SG:*

- Any external DC power supply is not required for excitation of circuit.
- PMSG doesn't require any slip rings to operate.
- No specific maintenance is required and easy to handle.
- No by-products formed and no pollution produces.
- For field, there is no power converter is required.
- Gear box is not needed in PMSG.

*Disadvantages of PM SG:*

- The cost of large permanent magnets is very high.
- Permanent Magnets performance gets affected by heat.
- Reliability is poor because of the uncontrolled air gap flux density is over voltages.

#### IV. CONCLUSION

This study analyzes the construction and working of the PMSG in the turbine of wind conversion system. The relationship between power generation and the wind speed energy is analyzed. The concept of using PMSG in the WCS has a wide future scope, as the need of more efficient ways to produce energy with minimum or least environmental impacts is large. In future more improved and efficient wind turbines can be constructed by using PMSG.

#### V. ACKNOWLEDGEMENT:

We would like to express our deep sense of gratitude towards our guide "**Prof. P. R. Gavali**", for his valuable help and guidance for the project. We are highly indebted to them for constantly encouraging us by giving critics on our work. We are grateful to them for having given us the support and confidence. We express gratitude towards "**Prof. Dr. Amol Admuthé**", Head of Computer Science and Information Technology Department, for providing support and giving me his valuable time. We also express gratitude towards our family members, and our friends for encouraging us with their valuable suggestions and motivating us from time to time

#### VI. REFERENCE

- [1] Lalit Kumar Gautam, Mugdha Mishra << Permanent Magnet Synchronous Generator Based Wind Energy Conversion System >> Moradabad Institute of Technology, Moradabad Volume 1, Issue 1 (February 2014), ISSN : 2348
- [2] Sandra Eriksson << Permanent Magnet Synchronous Machines >> Received: 2 July 2019 Accepted 29 July 2019 MDIP
- [3] Frede Blaabjerg, Florin Iov, Remus Teodorescu, Zhe Chen << Power Electronics in Renewable Energy Systems >> Aalborg University, Institute of Energy Technology Pontoppidanstraede 101, DK-9220 Aalborg East, Denmark
- [4] Bernardes, T., Montagner, V. F., Grndling, H. A., and Pinheiro, H. (2014). Discrete-time sliding mode observer for sensorless vector control of permanent magnet synchronous machine. *IEEE Transactions on industrial electronics*, 61(4), 1679–1691.
- [5] Morimoto, S., Nakayama, H., Sanada, M., and Takeda, Y. (2005). "Sensorless output maximization control for variable-speed wind generation system using IPMSG", *IEEE Transactions on Industry Applications*
- [6] Tan, K., and Islam, S. (2004). Optimum control strategies in energy conversion of PMSG wind turbine system without mechanical sensors. *IEEE transactions on energy conversion*, 19(2), 392–399.
- [7] Duan, R. Y., Lin, C. Y., and Wai, R. J. (2006). Maximum-power-extraction algorithm for grid-connected PMSG wind generation system. In *32nd Annual Conference on IEEE Industrial Electronics (IECON)*, 4248–4253.



[8] ] P. K. Goel S. S. Murthy, B. Singh and S. K. Tiwari. A comparative study of fixed speed and variable speed wind energy conversion systems feeding the grid. In Int. Conf. on PEDS, pages 736–743, 2007

[9] X. Wang, S. Yuvarajan, et L. Fan, « MPPT control for a PMSG-based grid-tied wind generation system », in North American Power Symposium (NAPS), 2010, 2010

[10] M. Park, C. Hwang, G.-H. Kim, B.-M. Song, et K. Y. Lee, « Voltage transient analysis of a PMSG wind power system using controller-hardware-in-the loops », in Innovative Smart Grid Technologies (ISGT), 2011 IEEE PES, 2011

[11] A. Dahbi, M. Hachemi, N. Nait-Said, et M.-S. Nait-Said, « Realization and control of a wind turbine connected to the grid by using PMSG », Energy Conversion and Management, vol. 84, p. 346–353, août 2014.

[12] M. Singh et A. Chandra, « Control of PMSG based variable speed wind-battery hybrid system in an isolated network », in Power & Energy Society General Meeting, 2009.

[13] <<Wind Energy Conversion System Connected With Grid Using Permanent Magnet Synchronous Generator (PMSG)>> Sourav Ghosh , Prof. Pradip Kumar Saha , Prof. Gautam Kumar Panda Vol. 4, Issue 1, January 2015

[14] Chia-Nan Wang, Wen-Chang Lin, and Xuan-Khoa Le << Modelling of a PMSG Wind Turbine with Autonomous Control>>  
Received 26 February 2014; Accepted 7 April 2014;  
Published 27 May 2014 Academic Editor: Her-Terng Yau  
Copyright © 2014 Chia-Nan Wang et al

[15] ] X. Yuan, F. Wang, D. Boroyevich, R. Burgos, and Y. Li, “DC-link voltage control of a full power converter for wind generator operating in weak-grid systems,” *IEEE Transactions on Power Electronics*, vol. 24, no. 9, pp. 2178–2192, 2009.

[16] ] J. Chen, H. B. Wu, M. Sun, W. N. Jiang, L. Cai, and C. Y. Guo, “Modeling and simulation of directly driven wind turbine with permanent magnet synchronous generator,” in Proceedings of the 2012 IEEE Innovative Smart Grid Technologies, Asia (ISGT '12), pp. 1–5, May 2012

[17] M. Yin, G. Li, M. Zhou, and C. Y. Zhao, “Modeling of the wind turbine with a permanent magnet synchronous generator for integration,” in Proceedings of the 2007 IEEE Power Engineering Society General Meeting, pp. 1–6, June 2007.

[18] A. D. Hansen and G. Michalke, “Modelling and control of variable-speed multi-pole permanent magnet synchronous generator wind turbine,” *Wind Energy*, vol. 11, no. 5, pp. 537–554, 2008

# IJEAST

INTERNATIONAL JOURNAL  
OF ENGINEERING APPLIED SCIENCE  
AND TECHNOLOGY

## ABOUT IJEAST

International Journal of Engineering Applied Science and Technology (IJEAST) is a peer-reviewed, open access journal that publishes high-quality research papers in the field of Engineering, Applied Science and Technology.

IJEAST aims to provide a platform for researchers, academicians, and professionals to share their innovative ideas, research findings, and practical experiences with the global scientific community.

## FOCUS AREAS

- Engineering
- Applied Science
- Technology
- Innovation & Development
- Interdisciplinary Studies



### PEER REVIEWED

All submissions are rigorously peer reviewed to ensure quality.



### OPEN ACCESS

Free and unrestricted access to research for all.



### GLOBAL REACH

Connecting researchers and professionals worldwide.



### TIMELY PUBLICATION

We ensure a swift and efficient publication process.



For more information, visit our website  
[www.ijeast.com](http://www.ijeast.com)



INTERNATIONAL JOURNAL  
OF ENGINEERING APPLIED SCIENCE  
AND TECHNOLOGY

✉ [editor@ijeast.com](mailto:editor@ijeast.com)

🌐 [www.ijeast.com](http://www.ijeast.com)

📍 India



2455-2143