



IJEAST

INTERNATIONAL JOURNAL
OF ENGINEERING APPLIED SCIENCE
AND TECHNOLOGY



VOLUME : 2 ISSUE : 9 Print / Issue Publication Date: 25-Mar-2018



ISSN : 2455-2143



Indexed In



WWW.IJEAST.COM

editor@ijeast.com



COMPARATIVE STUDY ON SINGLE STAGE STEP-UP RECTIFIERS FOR LOW VOLTAGE ENERGY HARVESTING APPLICATION

Anju Ramesh T
Department of EEE
M A College of Engineering,
Kerala, India

Prof. Jeena Joy
Department of EEE
M A College of Engineering,
Kerala, India

Prof. Jisha Kuruvila
Department of EEE
M A College of Engineering,
Kerala, India

Abstract— A AC-DC converter for low voltage and low power AC rectification applications, manages the energy harvested from micro-scale electromagnetic generators. A comparative study on the performance of converter with different topologies of single stage step-up rectifier is analyzed. A converter which integrates the conventional Buck-Boost converter and Boost converter into a single stage with shared energy storage inductor, a bidirectional switch and two split filtering capacitors is found to be more efficient. The Boost and the Buck-Boost topologies function in the positive and negative half input cycles, respectively. The inductor is energized by being shorted with the input source through the MOSFET channel without using the diodes. This converter successfully avoids the need of complicated and costly polarity detector circuit. Discontinuous conduction operation is adopted to decrease the switching losses and improve the efficiency. A circuit prototype, which converts a 0.4 V peak, 50 Hz AC voltage source to DC is designed and tested to verify the result. The simulation of the converters is performed using MATLAB/Simulink. The hardware realization is done using PIC16F877A controller.

Keywords— AC-DC converter, Energy harvesting, Boost, Buck-Boost, Low voltage.

I. INTRODUCTION

The advances made in low power wireless systems present an opportunity for alternative types of power source [1]. Solutions such as micro fuel cells and micro turbine generators are capable of high levels of energy and power density. However, they involve the use of chemical energy and require refueling. Energy harvesting approaches that transform light, heat and kinetic energy available in the sensors environment into electrical energy offer the potential of renewable power sources which can be used to directly replace or augment the battery.

Kinetic energy harvesters convert mechanical energy present in the environment into electrical energy. Typically, kinetic energy is converted into electrical energy using electromagnetic, piezoelectric, or electrostatic transduction mechanisms [1]. In comparison to electrostatic and piezoelectric transducers, electromagnetic transducers out perform in terms of efficiency and power density. Essentially, the energy harvesting system consists of a spring, a proof mass, it can be a magnet and an electrical damper, it can be coils [2]. The extrinsic vibrations excite the internal oscillation between the proof mass and electrical damper. The internal oscillation produces a periodically variable magnetic flux in the coil, which induces a corresponding alternating output voltage.

In energy harvesting systems, power electronic circuit forms the key interface between transducer and electronic load, which might include a battery [3]. The power electronic interface, can efficiently convert low amplitude AC voltage to a boosted and regulated DC voltage. The power electronic circuits are employed to regulate the power delivered to the load, and actively manage the electrical damping of the transducers so that maximum power could be transferred to the load [4]. The AC-DC converter for low voltage and low power AC rectification applications, manages the energy harvested from micro-scale electromagnetic generators.

Various AC-DC converters have been designed and developed through the years for the purpose of low voltage conversion [5]. These include single stage converters and multistage converters. That is, they either directly convert the AC input voltage to required DC output or they convert AC to DC and then stepped up or stepped down according to the requirement. The conventional AC-DC converter used for low voltage energy harvesting consist of two stages. The first stage is the diode bridge rectifier and the second is the DC-DC converter used to regulate the rectified AC voltage to DC voltage. An important drawback of this circuit is the



significant voltage drop caused by the diode bridge. Therefore, this circuit is infeasible for low voltage rectification.

II. SINGLE STAGE STEP-UP RECTIFIERS

To solve the problems regarding the conventional two-stage power converters, direct AC-DC converters were designed. In these converters, bridge rectification is avoided and the micro generator power is processed only in a single stage power converter. As a solution for these problems, single stage AC-DC converter topologies were developed. The important converters which does use bridgeless AC-DC rectification are discussed in the following sections.

A. Parallel combination of boost and buckboost converters–

The AC-DC converter, consists of a boost converter comprising of inductor L_1 , switch S_1 , and diode, D_1 in parallel with a buck-boost converter constituted by inductor L_2 , switch S_2 , and diode D_2 [6]. The output DC bus is realized by using a single capacitor. The output capacitor is charged by the boost converter in the positive half cycle and by the buck-boost converter in the negative half cycle. Fig. 1 shows the schematic of parallel combination of boost and buck-boost converters. A polarity detector is present in the circuit in order to determine the polarity of the input AC voltage.

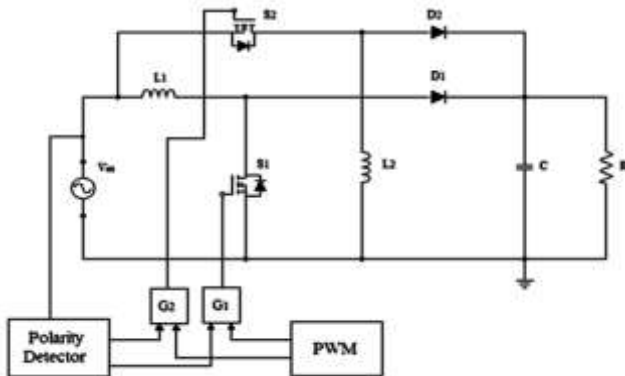

Fig. 1. Parallel combination of boost and buck-boost converters [6]

Mode I and mode II are during the positive half cycle. Mode III and mode IV occurs during the negative half cycle. Operating modes are shown in Fig. 2.

Mode I: Switch S_1 is turned ON. Switch S_2 is kept OFF and diode D_1 is reverse biased during this mode. The inductor L_1 gets charged through switch S_1 from zero.

Mode II: Switch S_1 is now turned OFF. The switch S_2 is kept OFF. The diode D_1 is forward biased. Now the stored charge on the inductor along with supply voltage will be delivered to the load. The inductor current of L_1 decreases and becomes zero. The circuit returns to mode I if the input AC voltage is still in the positive half cycle.

Mode III: Switch S_2 is turned ON. Switch S_1 is kept OFF and diode D_2 is reverse biased. The inductor L_2 gets charged through switch S_2 .

Mode IV: Switch S_2 is turned OFF and the diode D_2 is forward biased. Switch S_1 kept OFF. The inductor L_2 gets discharged through the load and charges the capacitor C.

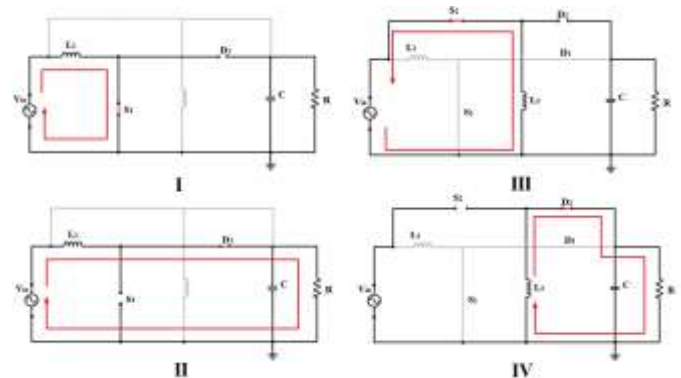

Fig. 2. Operating modes of parallel combination of boost and buck-boost converters

B. Bridgeless boost rectifier–

A bridgeless boost rectifier, shown in Fig. 3, is a unique integration of boost and buck-boost converters [4]. MOSFETs with bidirectional conduction capability work as two-quadrant switches to ensure the circuitry functionality in both positive and negative voltage cycles. Both boost and buck-boost topologies could share the same inductor and capacitor, thereby reducing the size and weight of the circuit.

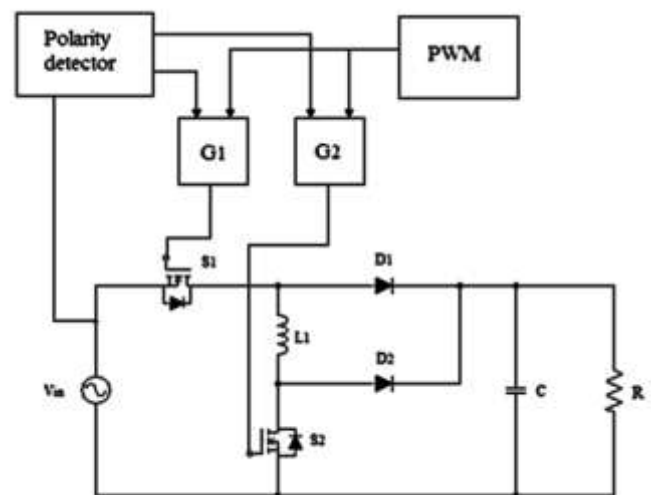

Fig. 3. Bridgeless boost rectifier [4]

The bridgeless boost rectifier has a total of 6 operating modes in one input AC voltage cycle, as shown in Fig. 4. Modes I-III illustrate the circuit operation during positive input cycle, where S_1 is turned ON while D_1 is reverse biased. The converter operates in boost topology during these modes while switching S_2 and D_2 . Modes IV-VI shows the negative input cycle operation. During these modes S_2 is turned ON and



D_2 is reverse biased. S_1 is switched during these modes to operate in buck-boost topology.

Mode I: The switch S_2 is turned ON. The inductor current is zero at this instant. In order to reduce the switching losses, S_2 is turned ON by Zero current switching (ZCS). The inductor L gets charged, as both S_1 and S_2 are conducting and both diodes D_1 and D_2 are reverse biased. The load will be powered by the stored energy in the capacitor.

Mode II: The switch S_2 is turned OFF. The energy stored in inductor during Mode I is now transferred to the load. The inductor current now decreases linearly. Switching loss occur during the turn ON of diode D_2 .

Mode III: As the inductor current become zero, D_2 will be automatically turned OFF. This will prevent the reverse recovery loss of the diode. During this interval, the load is again powered by the energy stored in the capacitor. After mode III, if the input voltage is still in the positive half cycle, the converter would return to the mode I.

Mode IV: The switch S_1 is turned ON. Zero current switching is achieved by ensuring the DCM operation of the converter. The energy is now transferred to inductor L . The load is powered by the energy stored in the output filter capacitor C .

Mode V: S_1 is turned OFF. During this period, the energy stored in the inductor is transferred to the load. The inductor current decreases linearly due to this. D_1 is forward biased during this mode and causing switching losses.

Mode VI: when the inductor current reaches zero, diode D_1 is turned OFF. Zero current switching is thus achieved. The charge stored in the output capacitor is continuously supplying the load. The converter would return to Mode IV as soon as S_1 is turned ON, if the input voltage is still in negative half cycle.

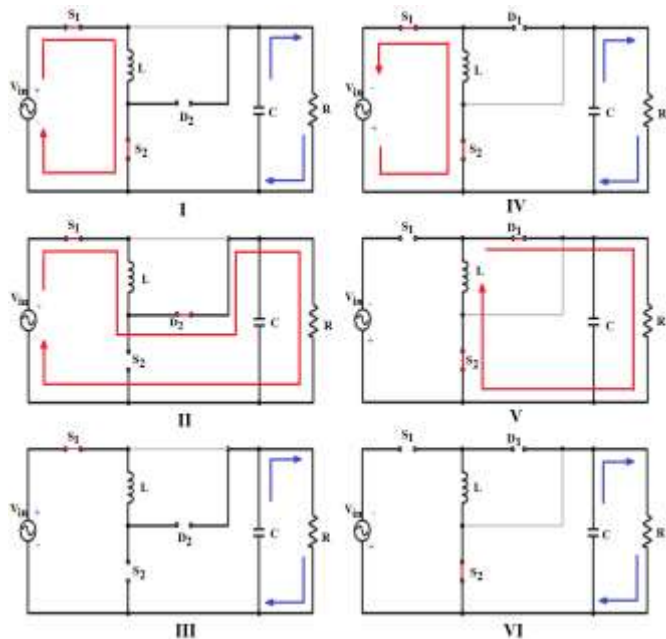

Fig. 4. Operating modes of bridgeless boost rectifier

C. DCM step-up rectifier–

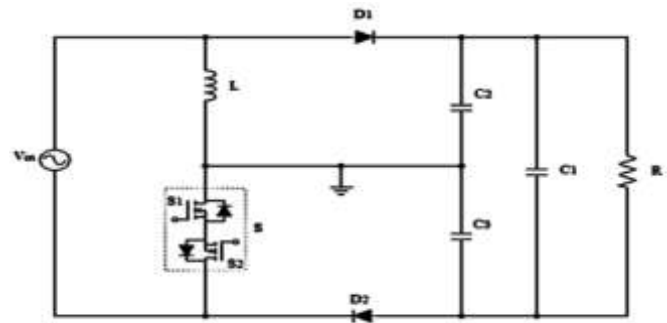

Fig. 5. DCM step-up rectifier [7]

The discontinuous conduction mode single stage step-up rectifier integrates the conventional Boost and Buck-Boost topologies with a shared inductor, a bidirectional switch and two split filtering capacitors [7] is shown in Fig. 5. In order to rectify the AC input to a DC voltage, the switch should be able to conduct and block currents in both directions during the on and off states, respectively. Since a MOSFET is a single quadrant switch, i.e. in on state, MOSFET channel can conduct bidirectional current; while in off state, it can only block unidirectional drain to source voltage. This is due to the existence of its body diode. Therefore, two n-MOSFET are placed in series with their body diodes back to back, to function as a four-quadrant switch. It should be noted that turning on and off of those two MOSFETs, they are always synchronized.

The single stage step-up rectifier has six operating modes, three in each half-cycle, they are shown in Fig. 6. Modes I-III correspond to the positive half-cycle, while modes IV-VI correspond to the negative half-cycle. In the positive half-cycle of the input voltage V_{in} , it operates as a Boost converter (including L , D_2 , and C_3). In the negative half-cycle of V_{in} , it operates as a Buck-Boost converter (including L , D_1 , and C_2). The discontinuous conduction mode (DCM) operation has the benefits of reduced switching losses and mitigated diode reverse recovery. Therefore, this converter is designed to operate in DCM.

Mode I: The switch is turned on, the inductor, L is energized by the input source. The inductor current, i_L increases linearly from zero. The switch, S is turned on with zero current. Therefore, switching losses are reduced. Meanwhile, both diodes are reverse biased. The output capacitors supply power to the load.

Mode II: The switch is turned off, i_L free-wheels via D_2 . C_3 is charged while C_2 is discharged. The voltage across the inductor equals to the difference between input voltage and lower capacitor voltage (V_{C3}), which is a negative value. Therefore, i_L decreases linearly until it crosses zero.

Mode III: When the i_L becomes zero, D_2 turns off naturally with a small di/dt . This significantly mitigates the diode



reverse recovery loss. The capacitors discharge themselves through the load. Given the input voltage is still positive, the converter returns to Mode I as soon as the switch turns on.

Mode IV: As the switch is turned on, the inductor current i_L linearly deviates from zero; the inductor is energized by the input source. The switch is also turned on at zero current. On the other hand, both diodes are reverse biased. The output capacitors supply power to the load.

Mode V: switch is turned off, i_L continues to freewheel via D_1 . C_2 is charged while C_3 is discharged. The voltage across the inductor equals to V_{C3} . Therefore, i_L increases linearly until it crosses zero.

Mode VI: As the inductor current, i_L increases to zero, D_1 turns off automatically. This avoids the reverse recovery losses of the diode. In this condition, the capacitors supply power to load again. Given the input voltage is still negative, the converter returns to Mode IV.

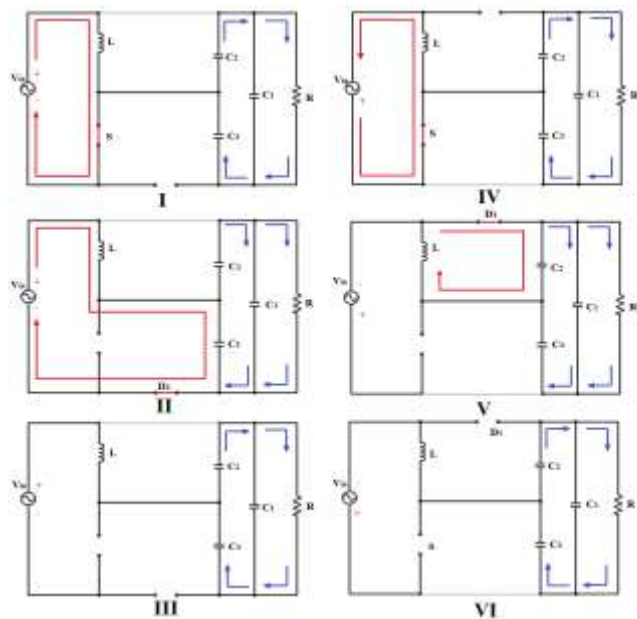

Fig. 6. Operating modes of DCM step-up rectifier

III. SIMULATION RESULTS

The simulations were done on MATLAB/ Simulink. Table 1 gives the simulation parameters for the converters discussed above.

Table -1 Simulation Parameters

COMPONENTS	PARAMETERS
Input voltage (V_{in})	0.4 V, 50 Hz
Switching frequency (f_s)	50 kHz
Duty ratio (d)	0.75
Inductor(s) (L)	10 μ H

Capacitor(s) (C)	200 μ F, 100 μ F
Resistive load	300 Ω

A. Parallel combination of boost and buckboost converters–

An input of 0.4V is given to the converter. Fig. 7 shows the input voltage, V_{in} and input current, I_{in} waveforms. The gate pulses are dependent on the polarity of the input voltage. Fig. 8 shows the output voltage, V_o and current, I_o waveforms. The output voltage is 3.05V DC with a ripple of 0.25V and has got a power output of 30.5 mW. Fig. 9 shows the switching stress V_{S1} and V_{S2} and they are 4V and 4.3V respectively.

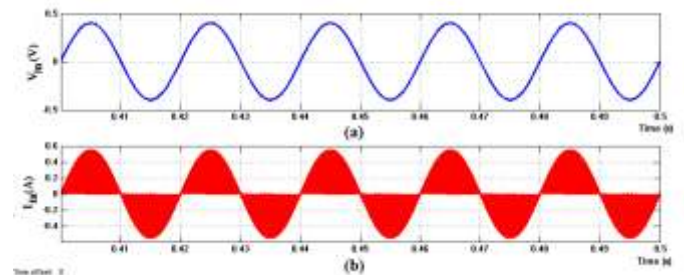

Fig. 7. (a) Input voltage, (b) Input current of parallel combination of boost and buck-boost converters

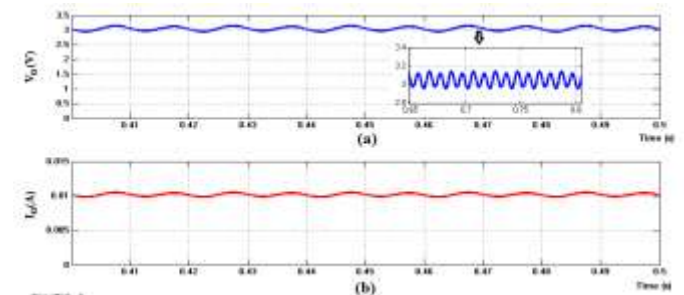

Fig. 8. (a) Output voltage, (b) Output current of parallel combination of boost and buck-boost converters

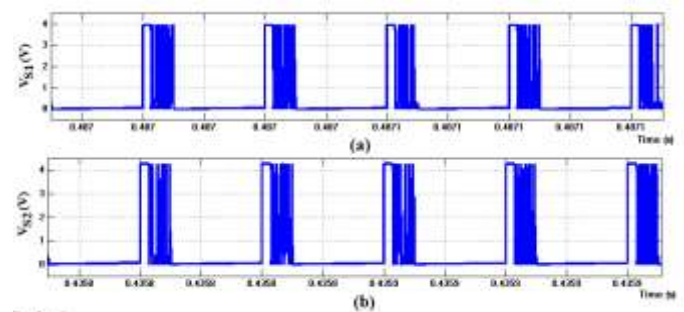

Fig. 9. (a) Stress across switch S_1 , (b) Stress across switch S_2 of parallel combination of boost and buck-boost converters

B. Bridgeless boost rectifier–

An input of 0.4V is given to the converter. Fig. 10 shows the input voltage, V_{in} and input current, I_{in} waveforms. The gate pulses are dependent on the polarity of the input voltage. Fig.



11 shows the output voltage, V_o and current, I_o waveforms. The output voltage is 3.08V DC with a ripple of 0.2V and has got a power output of 30.8 mW. Fig. 12 shows the switching stress across S_1 and S_2 as V_{S1} and V_{S2} and they are 4.2V and 3.9V respectively.

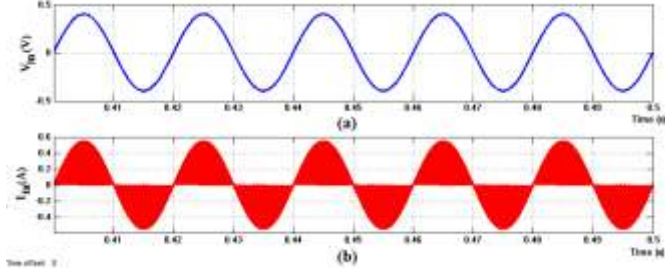

Fig. 10. (a) Input voltage, (b) Input current of bridge-less boost rectifier

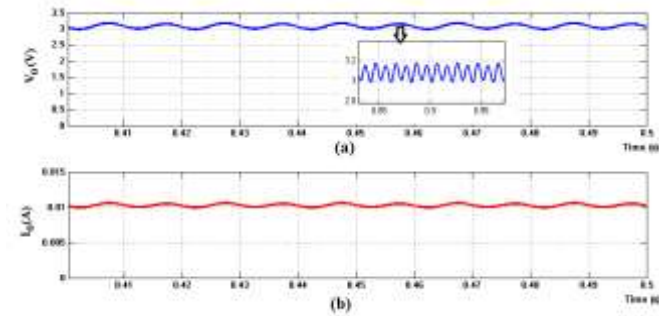

Fig. 11. (a) Output voltage, (b) Output current of bridge-less boost rectifier

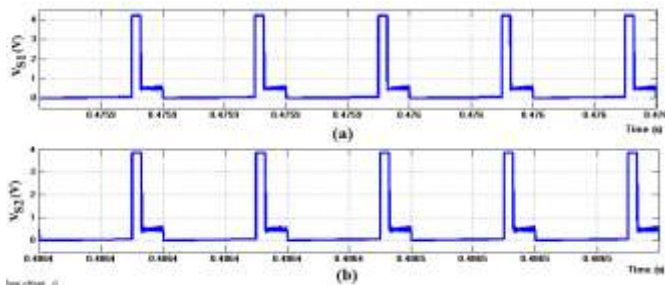

Fig. 12. (a) Stress across switch S_1 , (b) Stress across switch S_2 of bridge-less boost rectifier

C. DCM step-up rectifier–

An input of 0.4V is given to the converter. Fig. 13 shows the input voltage, V_{in} and input current, I_{in} waveforms. Fig. 14 shows the output voltage, V_o and current I_o waveforms. The output voltage is 3.25V DC with a ripple of 0.14V and has got a power output of 35.75 mW. Fig. 15 shows the switching stress V_S and is about 2.6V.

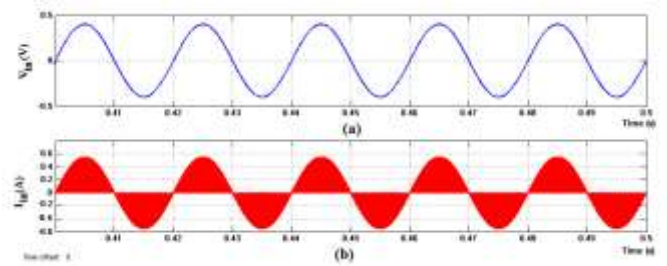

Fig. 13. (a) Input voltage, (b) Input current of DCM step-up rectifier

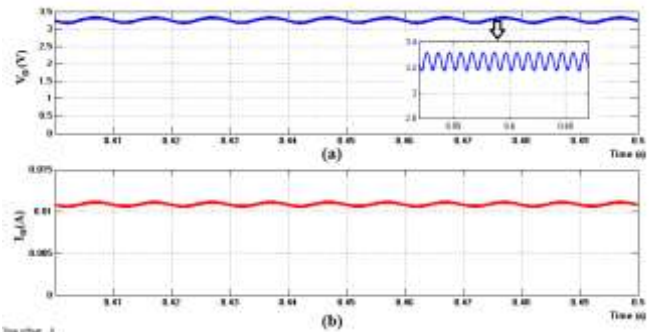

Fig. 14. (a) Output voltage, (b) Output current of DCM step-up rectifier

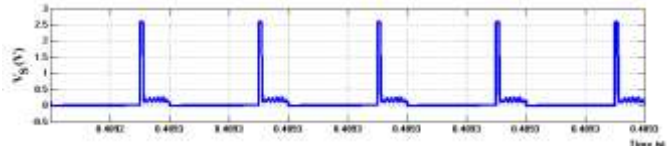

Fig. 15. Stress across switch S of DCM step-up rectifier

Table 2 shows the comparison of the above discussed converters for various parameters. From the comparison it is evident that the DCM step-up rectifier is having high gain, low switching stress and less complexity. A prototype of the DCM step-up rectifier is developed for the hardware implementation.

Table -2 Comparison of different converters

Converter/Parameter	Parallel boost & buck-boost	Bridgeless boost	DCM step-up rectifier
Inductor count	2	1	1
Polarity detector	Yes	Yes	No
Switching stress (V)	4.3	4.2	2.6
Output ripple (V)	0.25	0.20	0.14
Output voltage(V)	3.05	3.08	3.25
Boost ratio	7.63	7.7	8.13



Power Output(mW)	30.5	30.8	35.75
-------------------------	------	------	-------

IV. EXPERIMENTAL SETUP AND RESULT

The input to the rectifier is 0.4V, 50Hz AC. In order to obtain this we have used a voltage divider. Three resistors 10 Ω ,1W, 4.7 Ω ,1W, 1 Ω ,1W are connected across a 4.5V transformer and the voltage across 1 Ω resistor is taken as the input to the power circuit. As the current rating of the transformer is 500mA, only a current less than 500mA flows into the circuit. Control signal is generated using Proteus and programming is

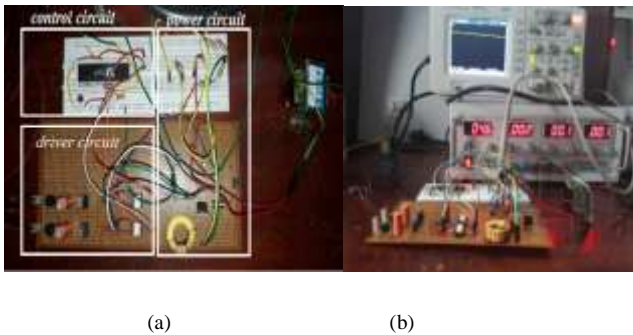

Fig. 16. (a) Different sections of the hardware, (b) Experimental setup



Fig. 17. Output of the converter

done in mikroC. Control scheme is developed by a cost effective simple method which uses a PIC16F877A. The PIC is configured to generate a switching frequency of 10KHz with a duty ratio of 75%. The MOSFET switches used are IRF540. The diodes used are schottky diodes. The power circuit consists of an inductor of 50 μ H, and three capacitors, two of them are 100 μ F and the other is 200 μ F. The load resistor used is 300 Ω . Different sections of the hardware is shown in Fig. 16(a), the entire experimental setup is shown in Fig. 16(b). Fig. 17 shows the output of the rectifier circuit. An output of 1.1V DC was obtained as output voltage. Here the input voltage is rectified and boosted.

V. CONCLUSION

After comparing different topologies of single stage step up rectifiers for low voltage energy harvesting applications, DCM step-up rectifier was found to be the most efficient rectifier. Therefore, it is suitable to be used in low-power micro-scale electromagnetic generators energy harvesting applications. This topology integrates the conventional Buck-Boost converter and Boost converter into a single stage with shared energy storage inductor and a four-quadrant switch. Four quadrant operation of switch is achieved by connecting two MOSFETS back to back and they are always synchronized. This converter successfully avoids the need of complicated and costly polarity detector circuit. Discontinuous conduction mode operation is adopted, so that zero current switching is possible, and thus the switching losses are reduced. The diodes are turned off naturally, which significantly reduces the diode reverse recovery losses. The single stage AC-DC converter developed is able to rectify and step up low amplitude AC voltages. Here, an AC input voltage of 0.4V, 50 Hz is converted to 1.1V DC.

VI. REFERENCES

- [1] S. P. Beeby, R. N. Torah, M. J. Tudor, P. Glynn Jones, T. O'Donnell, C. R. Saha, and S. Roy, "A micro electromagnetic generator for vibration energy harvesting", *J. Micromechanics Microengineering*, vol 17, no 7, pp 1257-1265, June 2007.
- [2] C. B. Williams, C. Shearwood, M. A. Harradine, P. H. Mellor, T. S. Birch, and R. B. Yates, "Development of an electromagnetic micro-generator", *IEEE Proceedings on Circuits Devices System*, volume 148, no 6, p 337, December 2001.
- [3] G. D. Szarka, B. H. Stark, and S. G. Burrow, "Review of power conditioning for kinetic energy harvesting systems," *IEEE Transaction on Power Electronics*, volume 27, no. 2, pp. 803-815, Feb. 2012.
- [4] H. Wang, Y. Tang, and A. Khaligh, "A Bridgeless Boost Rectifier for Low-Voltage Energy Harvesting Applications", *IEEE Transactions on Power Electronics*, volume 28, no 11, pp 5206-5214, November 2013.
- [5] E. Lefeuvre, D. Audigier, C. Richard, and D. Guyomar, "Buck-boost converter for sensorless power optimization of piezoelectric energy harvester", *IEEE Transactions on Power Electronics*, volume 22, no 5, 2018-2025, September 2007.
- [6] S. Dwari, L. Parsa, "An Efficient AC DC Step-Up Converter for Low-Voltage Energy Harvesting", *IEEE Transactions on Power Electronics*, volume 28, no. 8, August 2010.
- [7] Liang Yu, H. Wang, A. Khaligh "A Discontinuous Conduction Mode Single Stage Step-up Rectifier for Low



Voltage Energy Harvesting Applications”, IEEE Transactions on Power Electronics, volume 32, no. 8, August 2016.

- [8] P. P. Proynov, G. D. Szarka, B. H. Stark, and N. McNeill, “The effect of switching frequency, duty ratio, and dead times on a synchronous boost rectifier for low power electromagnetic energy harvesters”, Twenty-Seventh Annual IEEE Applied Power Electronics Conference Exposition, pp 667-674, 2012.
- [9] R. Dayal, S. Dwari, and L. Parsa, “Design and implementation of a direct AC-DC boost converter for low-voltage energy harvesting”, IEEE Transactions on Industrial Electronics, volume 58, no 6, pp 2387-2396, June 2011.

IJEAST

INTERNATIONAL JOURNAL
OF ENGINEERING APPLIED SCIENCE
AND TECHNOLOGY

ABOUT IJEAST

International Journal of Engineering Applied Science and Technology (IJEAST) is a peer-reviewed, open access journal that publishes high-quality research papers in the field of Engineering, Applied Science and Technology.

IJEAST aims to provide a platform for researchers, academicians, and professionals to share their innovative ideas, research findings, and practical experiences with the global scientific community.

FOCUS AREAS

- Engineering
- Applied Science
- Technology
- Innovation & Development
- Interdisciplinary Studies



PEER REVIEWED

All submissions are rigorously peer reviewed to ensure quality.



OPEN ACCESS

Free and unrestricted access to research for all.



GLOBAL REACH

Connecting researchers and professionals worldwide.



TIMELY PUBLICATION

We ensure a swift and efficient publication process.



For more information, visit our website

www.ijeast.com



INTERNATIONAL JOURNAL
OF ENGINEERING APPLIED SCIENCE
AND TECHNOLOGY

✉ editor@ijeast.com

🌐 www.ijeast.com

📍 India



2455-2143