



IJEAST

INTERNATIONAL JOURNAL
OF ENGINEERING APPLIED SCIENCE
AND TECHNOLOGY



VOLUME : 6 ISSUE : 11 Print / Issue Publication Date: 11-May-2022



ISSN : 2455-2143



DOI : 10.33564/IJEAST.2022.v06i11.019

Indexed In



WWW.IJEAST.COM

editor@ijeast.com



GESTURE BASED MONITORING SYSTEM FOR PARTIALLY PARALYSED PATIENTS

Dr. Joshi Manisha S

Professor & Head, Department of Medical Electronics,
BMS College of Engineering, Bangalore, India

Amogh B, Arpitha Kumar, Rakshith K Shetty, Yogeswarr S

Student, Department of Medical Electronics,
BMS College of Engineering, Bangalore, India

Abstract—The electronic document contains details on a device termed Gesture based monitoring system for partially paralysed patients. The device created and the idea originally belongs to RAY HealthTech. The concept of paralysis is explained initially, this is followed by the technical explanation of the device created, the electronic components and the physics of the Monitoring system.

Keywords—Paralysis, Ischemic Stroke, Partial paralysis, MPU6050, ESP32, Firebase and TP4056.

I. INTRODUCTION

Paralysis or Paraplegia is a condition that was discovered way back in 3000 BC in Egypt in Edwin Smith's Surgical papyrus. It was initially described as an injury to the spine. Most paralysis is due to strokes or injuries like spinal cord injuries and broken neck. Other causes of paralysis include: Nerve diseases such as Amyotrophic Lateral Sclerosis, Autoimmune diseases such as Guillain-Barre Syndrome. There are mainly four (4) major types of Paralysis - Monoplegia, Hemiplegia, Paraplegia and Quadriplegia. Paralysis mandatorily need not be full. It can also affect an individual partially.

Ischemic stroke is one of the most common types of strokes that occur across the globe. It is mainly caused due to brain blockage or clots caused in the artery of the brain.

According to the Indian Stroke Association, the incidence of stroke in India has increased by almost 100 per cent in the past few decades. Around 1.8 million people in India suffer from a stroke every year and it is only early treatment that can reduce morbidity and mortality.[1]

The patient can't be monitored continuously for any help or assistance which can lead to many serious health problems in case of emergency. The concept of a wearable watch for paralysis is under research. The current situation makes wearable watches for paralysis a need. This current situation led us to the creation of the Gesture based Monitoring System.

Paralysis or Paraplegia is a condition that was discovered

way back in 3000 BC in Egypt in Edwin Smith's Surgical papyrus. It was initially described as an injury to the spine. Most paralysis is due to strokes or injuries like spinal cord injuries and broken neck. Nerve illnesses, such as Amyotrophic Lateral Sclerosis, and autoimmune diseases, such as Guillain-Barre Syndrome, are other causes of paralysis. There are mainly four (4) major types of Paralysis - Monoplegia, Hemiplegia, Paraplegia and Quadriplegia. Paralysis mandatorily need not be full. It can also affect an individual partially.

The most common sort of stroke is the Ischemic Stroke. Ischemic stroke occurs when a blood clot or fatty deposit, known as plaque, blocks an artery that provides blood to the brain. This obstruction can occur in the neck or the skull. Clots are most commonly formed in the heart and migrate through the circulatory system. A clot can either break up or become stuck in an artery. Ischemic stroke caused by a fatty buildup happens when plaque breaks off from an artery and travels to the brain. Plaque can also build up in the arteries that supply blood to the brain and narrow those arteries enough to cause ischemic stroke.

Ischemic stroke is also more likely in those who have had previous strokes or who have a family history of stroke. Ischemic stroke is more common in men than in women, and blacks have a higher risk than other races or ethnic groups. Risk rises with age as well.

A cranial CT scan is performed to help distinguish ischemic stroke from other issues that cause brain tissue death, such as a hemorrhage or a brain tumor. In case the subject is diagnosed with ischemic stroke, an MRI is the best way to determine the root cause of ischemic stroke.

Treatment's primary goal is to get breathing, heart rate, and blood pressure back to normal. If required, the doctor will use medicine to try to lower the pressure in the brain. Intravenous tissue plasminogen activator (tPA), which dissolves clots, is the most common treatment for ischemic stroke. Because tPA might induce bleeding, it mustn't be given more than five hours after the onset of the stroke. You also can't take it if you have a history of hemorrhagic stroke, brain hemorrhage, or recent severe surgery or head injury.



To avoid future clots, long-term treatments include aspirin (Bayer) or an anticoagulant.

II. LITERATURE SURVEY AND CASE STUDY

In this paper, the Literature survey has been conducted by reading each and every paper covered. A relation of the disease and the device have been interconnected in the process.

Review 1: The first review that is considered, is retrieved by searching the latest assistive Technologies being adopted after a patient suffered after stroke. This included searches in IEEE Xplore, ncbi.nlm.gov.in and ResearchGate.[5]

Electrical or mechanical devices that help people recover from stroke have shown clinical benefits in upper-limb rehabilitation. However, few people currently use these tools in practice. This study aimed to identify the barriers and facilitators that prevent stroke self-management using assistive technology. Around 8 percent of stroke survivors experience upper limb impairment after their stroke. Although estimates of recovery vary depending on the severity of the condition, most of them are not able to walk or use their limbs properly. It is widely acknowledged that stroke affects the quality of life of stroke survivors and their families. The cost of care related to stroke is also significant. There were significant systemic impediments found in realizing the potential of assistive technologies in upper-limb stroke therapy. Increased evidence of assistive technology effectiveness and clinical service provision must be prioritized. To develop new funding mechanisms, enhance device design, and boost knowledge and training in assistive technology use, device manufacturers, researchers, health professionals, service funders, and persons with stroke and family carers must collaborate creatively and together.

In this paper, the Literature survey has been conducted by reading each and every paper covered. A relation of the disease and the device have been interconnected in the process.

Review 2: The second review that is considered, is retrieved by reading the Tongue Operated Assistive Technologies being adopted after a patient suffered after stroke. This included searches in IEEE Xplore, ncbi.nlm.gov.in and ResearchGate.[4]

Assistive technology helps severely disabled people improve their quality of life by allowing them to engage in self-care, educational, vocational, and recreational activities. The tongue possesses a set of properties that make it a good appendage for manipulating paralysed people's environs via tongue-operated assistive devices. A few of these gadgets have been tested, and a new one dubbed Tongue Drive has been released. Motor homunculus, The motor cortex of the tongue and mouth is comparable to that of the fingers and hand. Unlike the eyes, which have extensive cortical

representations but were developed as sense organs, the lips and tongue were developed as motor organs. As a result, they are capable of complex motor control and manipulation tasks by nature, as evidenced by their function in vocalization and swallowing. The hypoglossal cranial nerve connects the tongue to the brain, and it is normally immune to injury and disease. The Tongue Drive System (TDS) can detect the position of the tongue inside the oral cavity wirelessly and transform its motions into a set of user-defined commands. These commands can then be utilized to control the user's environment, access a computer, or drive a wheelchair. TDS is made up of a series of magnetic sensors fixed on a headset and placed inside the mouth, either on the outside surface of the teeth on an orthodontic brace or on the exterior of the mouth near the user's cheeks. The sensor array detects the magnetic field of a small permanent magnet, about the size of a grain of rice, affixed to the tongue by tissue adhesives, implantation, piercing, or clipping. The sensor signals are multiplexed, digitized, and wirelessly transferred to an external wireless interface that the user wears or is linked to his or her bed or wheelchair. In this paper, the Literature survey has been conducted by reading each and every paper covered. A relation of the disease and the device have been interconnected in the process.

Review 3: The third review that is considered, is retrieved by reviewing the Emerging concerns of Older stroke Patients being adopted after a patient suffered after stroke. This included searches in IEEE Xplore, ncbi.nlm.gov.in and ResearchGate.[3]

Assistive gadgets help people with physical disabilities to live more independently and are an important part of rehabilitation. Little is known about the worries, views, and beliefs that older patients have about assistive technology. The device impressions of 103 stroke patients in rehabilitation were described using a structured, qualitative approach in this study. The operation and utility of gadgets, social contexts and repercussions, and attributions of cultural meanings of use were recognised as six categories of patient concerns. The initial use of the gadget created cultural value difficulties due to differences in sociocultural views and opposing normative expectations. These factors indicate new opportunities for social science study and clinical practice enhancements. This study is the first to look into how one group of older people, those who have had a stroke and have returned home, feel about the assistive equipment they receive throughout their rehabilitation. The findings reveal that the emergent meanings attached to rehabilitation devices are more nuanced than merely looking at use rates or evaluating perceptions in terms of positive and negative likes and dislikes. That is, in the context of the six dimensions and 11 subjects derived in this article, the like or disliking of devices as objects is more completely



explicated and, thus, comprehended. Personal interpretations and social evaluations affected worries about newly acquired physical restrictions and the necessity to use technology, according to the empirical data on these dimensions and themes. We believe that more empirical insight into the actual conduct of rehabilitation and patients' first-hand experiences with devices will give therapeutic and scientifically productive avenues for enhancing the successful utilization of devices as older patients move from hospital to home. More research is clearly needed to understand the trajectory of this group's and others' experiences with devices after hospitalization and throughout time.

In this paper, the Literature survey has been conducted by reading each and every paper covered. A relation of the disease and the device have been interconnected in the process.

Review 4: The fourth review that is considered, is retrieved by reviewing the Assistive technologies for the upper extremities being adopted after a patient suffered after stroke. This included searches in IEEE Xplore, ncbi.nlm.gov.in and ResearchGate.[6]

Technical advancements may be able to compensate for the loss of upper-limb motor functions following a stroke. However, the vast majority of designs fall short of meeting the demands and preferences of end customers. According to user-centered design methodologies, paying attention to user perspectives throughout the development of assistive technology results in devices that are better suited to the users' needs. In total, 9 studies were included, with data acquired through focus groups, questionnaires, and interviews. Five overarching but highly interdependent themes emerged as barriers and enablers influencing the adoption of assistive technology for the upper limb after stroke: (1) promoting hand and arm performance; (2) attitude toward technology; (3) decision process; (4) usability; and (5) practical applicability. When an assistive technology has a clear therapeutic base (expected benefit in enhancing function), its users (patients and health care professionals) have a positive attitude toward technology, enough information about the assistive technology is available, and usability and practical applicability have been successfully addressed in its design, expected use of the technology is facilitated. Because the highlighted themes are interdependent, all factors impacting user perceptions of assistive technology must be taken into account while building assistive technology to improve its chances of acceptability. Each factor's value varies depending on personal variables and the context of use, whether at home as an assistance device or in a clinic for rehabilitation.

III. AIM AND SCOPE

The Gesture based Assistant for Partially Paralyzed Patients is a non - invasive Wearable Device worn by the patient on the wrist. The wearable device is like an assistant when the guardian / caretaker / family member is a few meters away from home.

Partially Paralyzed Patients or Paralyzed patients require constant assistance to eat food, use the washroom, drink water, etc., Some of them may not be able to communicate clearly as the stroke hampers their speech. To ease it for the guardian or caretaker, the watch is tied to the wrist to help them understand the needs of the patient.

A. Problem Definition

Ischemic stroke is mainly caused due to brain blockage or clots caused in the artery of the brain. According to the Indian Stroke Association, the incidence of stroke in India has increased by almost 100 per cent in the past few decades. Around 1.8 million people in India suffer from a stroke every year and it is only early treatment that can reduce morbidity and mortality. The patient can't be monitored continuously for any help or assistance which can lead to many serious health problems in case of emergency.

B. Existing Alternative

Assistive technology helps severely disabled people improve their quality of life by allowing them to engage in self-care, educational, vocational, and recreational activities. The tongue possesses a set of properties that make it a good appendage for manipulating paralyzed people's environs via tongue-operated assistive devices.[2]

A 4 wheel walker and rotators, which helps the patient to ask for help and control the wheelchair by his head movement using the joystick.

C. Working

The Gesture based Partially Paralyzed Patients can communicate their needs through hand based movements. For example, if the patient moves his hand/ wrist to the right it means he's thirsty, if the patient moves his hand/ wrist up, it means that he's hungry, if he moves his hand to the left it means he wants to use the washroom. The movement of the hand/ wrist will be tracked by the Gesture based Partially Paralyzed watch.

The Alarm will be given to the nurse/ guardian or caretaker on the phone or tablet.

IV. METHODOLOGY

The methodology involved in the project is all about sensing the slightest body moment of a partially paralyzed patient using a gyroscope.

A gyroscope sensor works on the principle of Conservation of Angular Momentum. It works by preserving the angular



momentum. In a gyroscope sensor, a rotor or a spinning wheel is mounted on a pivot.... Whenever we spin the rotor of the gyroscope, the gyroscope will continue to point in the same direction.

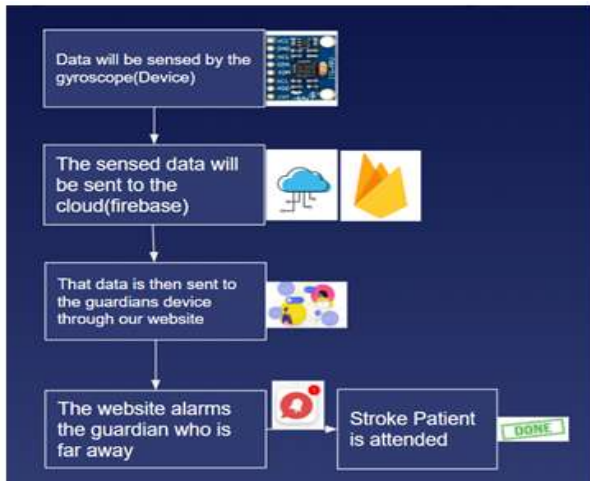

Fig. 1. Block Diagram of the overall Device

Mechanism

1. The MPU6050 (Accelerometer and Gyroscope) sensor detects the motion of the patient’s hand. Here only the Acceleration is detected which is sufficient to track the patient’s movement.
2. The data is sent to the Microcontroller ESP32.It communicates using the standard I2C (Inter-Integrated Circuit) protocol.
3. The ESP32 processes the data and detects if left, right, up and down(movement of hand). If any gesture is detected the acceleration value and the particular gesture is sent to Firebase Realtime Database.
4. Before ESP32 communicates with Firebase there are some initial procedures. The ESP32 should be fed with login credentials of the user or else data won't be sent; this enhances device security and privacy of the user.
5. Now, the data has to be fetched and sent to the user, our website fetches the data from Firebase. In our website the same login credentials which were given to ESP32 have to be fed.
6. The website alarms the guardian/ caretaker phone and thus the patient can be attended with ease.

A. Why ESP32 as the microcontroller?

The main requirement of the Gesture Based Tracker is wireless communication for data transfer, ESP32 has Bluetooth and WiFi communication for data transfer. So hence, there is no requirement of an external module for data transfer. Bluetooth is used to feed initial credentials like WiFi ssid / password and login credentials. One of the main aspects of wearable devices or IoT(Internet of Things) devices is to be battery efficient. The ESP32 only

requires an extra current initially to connect to WiFi and gather the IP address. It has an Ultra-low-power (ULP) co-processor which can be used when there is not a lot of motion of the patient (Say sleeping), at this time the core CPU can be put off and thus battery consumption will be very low. The ULP co-processor has the capability to access the peripherals, timer during this deep-sleep-mode of the CPU. When there is a gesture detected using an external event the CPU can be put into normal mode and data can be sent to Firebase Realtime Database.

The ESP32 has support for almost every communication protocol which makes it advantageous over other microcontrollers. The ESP32 comes with an inbuilt temperature sensor which can detect the user's temperature.

B. Procedure to Use the Gesture Based Tracker

1. When the Gesture Based Motion tracker is purchased/ prescribed, it is essential for the caretakers to visit the website Ray Healthtech <https://ray-health-tech.vercel.app/>. The guardian/ caretaker needs to login through the website and fill in the details of the patient and also fill in their details.
2. The next Procedure is to connect the Gesture based monitor to the phone or tablet that will be used. This connection happens through bluetooth and WiFi.
3. Once the watch and Phone are configured, the tracker can be tied to the Partially paralysed patients
4. When the Patient moves his hand, an alarming sound will be produced by the watch and an alarm will also be given in the phone or tablet.
5. The website will also tell the need of the patient based on his gesture. Once the patient is attended, the guardian/ caretaker needs to select the button attended. That gets noted on the website.

C. Pre-Defined Gestures

Movement of Hand	Command
UP	Want to drink water.
DOWN	Want to go to the washroom.
LEFT	I'm Hungry.
RIGHT	Want medicine.

All the above configurations can be edited with the user requirement and can be done on our website.

D. Abstract specification of the subsystems

1. ESP32

ESP32 (wifi and microcontroller) → To control the overall operation.

The ESP32 is a low-cost, low-power microcontroller series with Wi-Fi and Bluetooth capabilities, as well as a highly integrated structure driven by a dual-core Tensilica Xtensa LX6 microprocessor. This paper compares the ESP32 to some of its competitors on the market and introduces the microcontroller's specifications, features, and programming details. The embedded memory is 448KB ROM, 520KB SRAM and has two 16KB RTC memory. [7]



Fig. 2. ESP 32 - Microcontroller and Wifi

2. MPU6050

Gyroscope/Accelerometer MPU6050 → To detect the gesture.

The ITG MPU-6050 sensor combines a MEMS accelerometer and a MEMS gyroscope onto a single chip. Both the accelerometer and the gyroscope have three axes that can capture x, y, and z with each channel having 16-bit analogue to digital conversion circuitry. Mpu-6050 communicates through I2C, which is a multi-master, multi-slave, single-ended, serial computer bus with low speed but high utility due to the use of only two wires: SCL (clock) and SDA (data).[8]



Fig. 3. MPU6050 - Gyroscope and Accelerometer

3. Firebase

Firestore Realtime Database - Publish and retrieve Data

Firestore is a platform for developing web applications. It aids developers in the creation of high-quality apps. It saves data in the JavaScript Object Notation (JSON) format, which eliminates the need for queries when inserting, updating, deleting, or adding data. It's the part of a system that acts as a database for storing information.[9]

A real-time database and backend are among the services provided by Firestore. The application developer is given an API that allows application data to be synchronized among clients and stored in Firestore's cloud. The company provides client libraries that allow for integration with Android, iOS, and JavaScript apps.

Firestore Auth - To authenticate the user for privacy

Facebook, Google GitHub, and Twitter are among the social login providers supported by Firestore Auth. It is a premium service that allows users to be authenticated using solely client-side code. It also offers a user management system that allows developers to leverage email and password logins stored in Firestore for user authentication.

Firestore Firestore - Store user important details

It stores the information as a JSON file. This type of storage helps to store the details of the user like name, age etc., And stores the important gesture commands.

4. TP4056 Battery charging circuit

It has an input voltage of 5v which can be given through an USB type-B cable or give direct voltage to the input terminals. The output voltage of the chip is 3.7v - 4.2v.

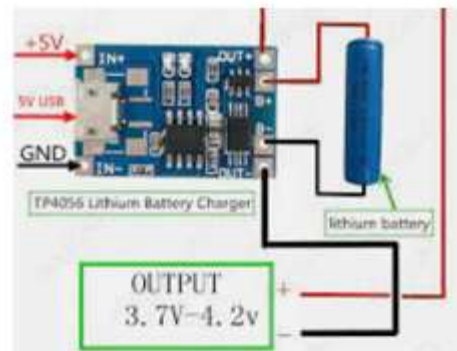

Fig. 4. TP4056 charging circuit with 3.7v Li-Po Battery

5. Push Buttons



Fig. 5. Push Buttons

E. Software Implementation

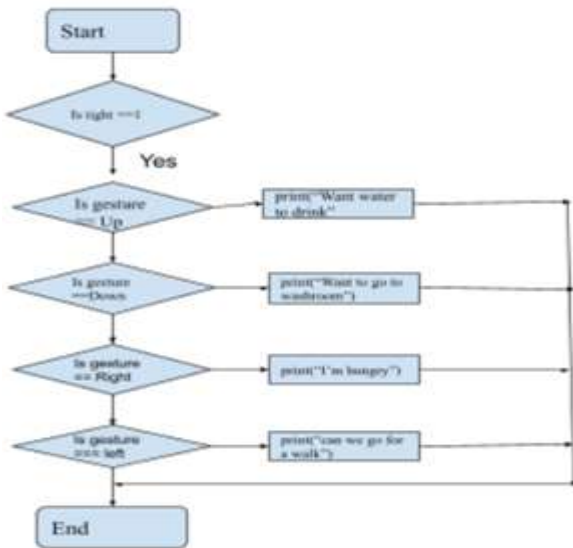

Fig. 6. Flowchart Software Implementation

V. RESULTS AND DISCUSSION

A. Walkthrough of the website.

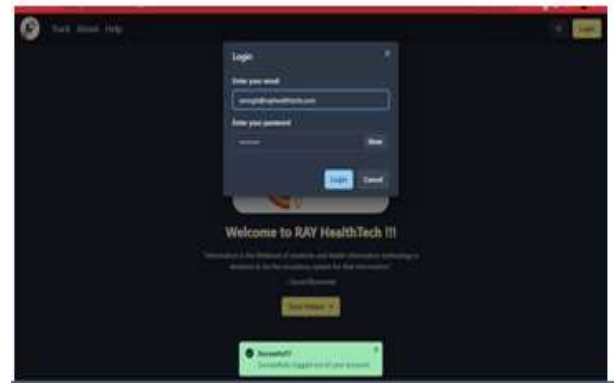
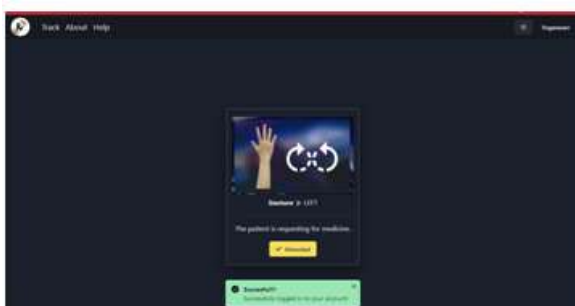

Fig. 7. Snapshots from the website



Initially we login using the credentials (Has to be created for a new user). Later, he can track the patients based on his/her gesture through the “track” tab in the website.

B. Hardware Assembly



Fig. 8. Hardware implementation

Pin of ESP32	Pin of MPU6050
D21	SDA
D22	SCL
3v3	VCC
GND	GND



VI. CONCLUSION

In the present proposed solution, MPU6050 has been connected to the ESP32. The data from MPU6050 is sent to ESP32 and then is published to Firebase Realtime Database. Using this data the caretaker is altered through our website. The website has the capability to change the user's commands and personal details. It is published on the internet through a provider called Vercel.

VII. FUTURE SCOPE

As discussed, IoT based non-invasive health vital monitoring will play a major role in the field of healthcare. In this busy world, having a person dedicated only to monitor a patient is hardly possible. Having said the disadvantages and problems that physical monitoring possesses, it's always a great advantage in having a remote monitoring system. Hence, the device we have developed will have great potential in the healthcare market.

By using machine learning-like algorithms, the device can be developed into an even more effective non-invasive monitoring system. Also by adopting complex programming, the device can be developed as a body vital measuring device and not just a monitoring system.

VIII. ACKNOWLEDGMENT

Teamwork leads to success is what we at RAY Healthtech believe. We, the team of RAY, have supported one another in doing the Gesture based Motion tracker for Partially Paralyzed patients.

During the journey of this project we would like to thank all our Professors and Head for guiding and supporting us. Firstly we would like to thank our Head of Department Dr. Joshi Manisha S for providing us with the opportunity to work on this project. We would also like to thank our guide Dr. Joshi Manisha S for her guidance and valuable advice at every single stage of the project.

IX. REFERENCES

- [1]. Maceira-Elvira, P., Popa, T., Schmid, AC. et al. "Wearable technology in stroke rehabilitation: towards improved diagnosis and treatment of upper-limb motor impairment". *J NeuroEngineering Rehabil* 16, 142 2019, DOI :<https://doi.10.1186/s12984-019-0612-y>
- [2]. Eric Wicklund, "New mHealth App Identifies Stroke Signs Through Speech, Facial Movements", Article October 27 2020
- [3]. Demain S, Burrige J, Ellis-Hill C, et al. "Assistive technologies after stroke: self-management or fending for yourself? A focus group study". *BMC Health Serv Res.* 2013;13:334. Published 2013 Aug 22. DOI:10.1186/1472-6963-13-334

- [4]. Kim J, Park H, Ghovanloo M. "Tongue-operated assistive technology with access to common smartphone applications via Bluetooth link". *Annu Int Conf IEEE Eng Med Biol Soc.* 2012;2012:4054-4057. Published 2013. DOI:10.1109/EMBC.2012.6346857.
- [5]. Gitlin LN, Luborsky MR, Schemm RL. "Emerging concerns of older stroke patients about assistive device use." *Gerontologist.* 1998;38(2):169-180. DOI:10.1093/geront/38.2.169
- [6]. Van Ommeren AL, Smulders LC, Prange-Lasonder GB, Buurke JH, Veltink PH, Rietman JS. "Assistive Technology for the Upper Extremities After Stroke: Systematic Review of Users' Needs." *JMIR Rehabil Assist Technol.* 2018;5(2):e10510. Published 2018 Nov 29. DOI:10.2196/10510
- [7]. A. Maier, A. Sharp and Y. Vagapov, "Comparative analysis and practical implementation of the ESP32 microcontroller module for the internet of things," 2017 *Internet Technologies and Applications (ITA)*, 2017, pp. 143-148, DOI: 10.1109/ITECHA.2017.8101926.
- [8]. Al-dahan, Prof. Ziad & Bachache, Nasseer & Bachache, Nasseer. "Design and Implementation of Fall Detection System Using MPU6050 Arduino." 180-187. 2016, 10.1007/978-3-319-39601-9_16.
- [9]. Khawas, C., & Shah, P.G. Application of Firebase in Android App Development-A Study. *International Journal of Computer Applications.* 2018, DOI:10.5120/IJCA2018917200.

IJEAST

INTERNATIONAL JOURNAL
OF ENGINEERING APPLIED SCIENCE
AND TECHNOLOGY

ABOUT IJEAST

International Journal of Engineering Applied Science and Technology (IJEAST) is a peer-reviewed, open access journal that publishes high-quality research papers in the field of Engineering, Applied Science and Technology.

IJEAST aims to provide a platform for researchers, academicians, and professionals to share their innovative ideas, research findings, and practical experiences with the global scientific community.

FOCUS AREAS

- Engineering
- Applied Science
- Technology
- Innovation & Development
- Interdisciplinary Studies



PEER REVIEWED

All submissions are rigorously peer reviewed to ensure quality.



OPEN ACCESS

Free and unrestricted access to research for all.



GLOBAL REACH

Connecting researchers and professionals worldwide.



TIMELY PUBLICATION

We ensure a swift and efficient publication process.



For more information, visit our website

www.ijeast.com



INTERNATIONAL JOURNAL
OF ENGINEERING APPLIED SCIENCE
AND TECHNOLOGY

✉ editor@ijeast.com

🌐 www.ijeast.com

📍 India



2455-2143