



# IJEAST

INTERNATIONAL JOURNAL  
OF ENGINEERING APPLIED SCIENCE  
AND TECHNOLOGY



**VOLUME : 2    ISSUE : 6    Print / Issue Publication Date: 29-Nov-2017**



**ISSN : 2455-2143**



Indexed In



[WWW.IJEAST.COM](http://WWW.IJEAST.COM)

[editor@ijeast.com](mailto:editor@ijeast.com)



# HIGH THROUGHPUT FFT/IFFT ARCHITECTURE FOR MIMO OFDM: A REVIEW

M.V.Nageswara Rao  
 Department of ECE  
 GMR Institute of Technology  
 Rajam,  
 Andhra Pradesh, India

Pogiri Revathi  
 Department of ECE  
 SVCET  
 Etchela  
 Andhra Pradesh, India

L.Govinda Rao  
 Department of ECE  
 GMR Institute of Technology  
 Rajam  
 Andhra Pradesh, India

**Abstract**— Digital signal processing (DSP) is widely involved in the technology of everyday use. This prevalence drives the research interest for developing DSP algorithms for the VLSI implementations with better performance. Moreover, such implementations should offer lower power, higher speed and lower area. This leads the scope for novel algorithms, architectures for wireless communications applications like MIMO, OFDM, advanced channel coding. The Fast Fourier transform (FFT) processor is the key component in an OFDM system. In this paper, the hardware complexity, performance of various FFT architectures reported in the literature for OFDM applications are reviewed and compared. In this review, the architectures aimed for various wireless technologies such as IEEE 802.11ad, IEEE 802.11n, IEEE 802.11n etc.

**Keywords**— FFT/IFFT, OFDM, MIMO, Wi-Fi, WIMAX

## I. INTRODUCTION

IEEE 802.11ac standard which was recently recommended is the fastest Wireless Fidelity (Wi-Fi) technology, offers faster data rates compared to the earlier technologies like IEEE 802.11ac. Association of industries and IEEE are working to enable the technology offers the data rates up to 7 Gbps for applications like high definition video streaming on smart phones. The high throughput processing can be achieved with multiple input multiple output (MIMO) systems. In the physical layer of MIMO system, orthogonal frequency division multiplexing (OFDM) technique is being widely adopted. A simplified block diagram of the OFDM communication system is shown in Fig.1.

In the Orthogonal Frequency Division Multiplexing, the Fast Fourier transform (FFT) processor is a key component. Here, data to be communicated is treated as a frequency-domain representation of the signal. IDFT (IFFT) is used to derive the time domain signal from data before transmission. At the

receiver, FFT is used to get back the data (frequency domain representation of the signal) from the received signal.

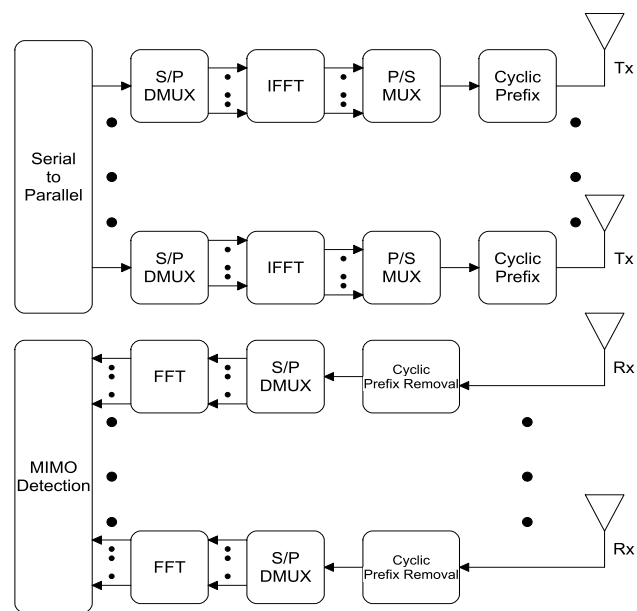

Fig.1. A Complete OFDM communication system

## II. LITERATURE REVIEW

OFDM technique is widely adopted in various applications like digital subscriber lines [1], [2], [3] for modems in wired-communication, and IEEE802.11 [4] Wi-Fi, IEEE802.16 [5], [6] 3GPP long term evolution (LTE) for wireless-communication modems used in base band data processing. To convert the modulated information from frequency domain to time domain Inverse fast Fourier transform (IFFT) is employed at the transmitter. In contrast, FFT collects samples from the time domain and are restored in the frequency domain at receiver. On other hand, Multiple Input Multiple



Output (MIMO) technique dramatically improves the data throughput. Therefore, MIMO-OFDM system can offer high data throughput for wireless communications [7].

During the last few decades, many researchers reported the FFT/IFFT architectures in literature for various OFDM applications. A mixed radix FFT with continuous flow data output is reported in [8], [9]. Here, seamless data processing is achieved by employing two memory blocks of size-N to generate output stream seamlessly. In this architecture, one of the memory block is used in the processing of current FFT/IFFT symbols, and the other memory block stores the earlier FFT/IFFT outcomes. Various pipeline FFT/IFFT architectures presented in the literature can be classified as single or multi path delay feedback (SDF or MDF) and single or multipath delay commutator (SDC or MDC) architectures [10]. In order to generate seamless output SDF schemes possess feedback paths to handle intermediate results in each pipe [11-20]. In contrast, various feed forward architectures based on radix- $2^k$  are reported in [1], [21], [22], [47], [54] [56]. The proposed pipelined architecture in [30] for RFFT is designed on the radix-2 algorithm. However, this technique cannot be generalized for higher radix algorithms. This issue is resolved by the technique proposed in [31]. In order to reduce the computational complexity numerous algorithms for FFT computation are reported in the literature, out of which the Cooley-Tukey radix-2 FFT [32] is very prevalent. Some standard FFT architectures in the literature [14], [35-39] are based on radix-4 [33], split-radix [34], radix- $2^2$  [21] algorithms, which are based on radix-2 algorithm. Radix-2 multi-path delay commutator (R2MDC) is proposed in [35], which is one of the most classical approaches for pipelined implementation of radix-2 FFT. By utilizing the R2MDC storage buffer effectively, the R2SDF architecture is achieved with reduced memory [35]. R4SDF [36] and R4MDC [37], [38] have been reported as radix-4 R2SDF and R4MDC. In [39], modified radix-4 algorithm is used to reduce the complexity of the R4MDC architecture, radix-4 single-path delay commutator (R4SDC) is proposed. Various parallel architectures for FFT are reported in [11], [22], [27], [40], [41]. These hardware architectures has high hardware complexity with poor utilization.

A method for decompose of discrete Fourier transform matrix reported in [13] enables the systematic implementation of the pipelined FFT processor. SDF schemes proposed in [11], [12] employ feedback paths to handle the intermediate results at each stage and to offer continuous processing. Here,

FFT/IFFT processor generates the first output sample immediately after feeding the last input sample. Moreover, SDF schemes can process multiple data streams by employing one FFT/IFFT processor when the input data is properly scheduled. MDC topology is adopted in [1], which saves area compared to SDF FFT when there are multiple streams to process. However, MDC schemes require more memory for switch-box realization [23]. In MDC architecture, the radix-k butterflies are left unused till the arrival of kth input. Therefore, the butterfly hardware utility rate of the MDC FFT/IFFT computing core is  $1/k$ , where it is 100% for SDF FFT/IFFT [1] [10]. Hence,  $(k-1)/k$  computing resources and memory are kept idle in MDC with single stream of input [1]. This utilization rate MDC can be made 100% by increasing the number of streams to  $r$  when the streams are properly scheduled and ordered to feed the pipelined FFT/IFFT. Hence, MDC FFT/IFFT is suitable in MIMO systems.

In MIMO system, to manage the multiple data streams, multiple functional blocks may be needed for the replicated processing of parallel input streams. However, this results in linearly increased FFT/IFFT complexity in MIMO systems. In earlier reported literature, the butterflies and memory are intuitively duplicated as per the number of data streams, and explored the techniques to exploit parallelism with diminished complexity. In MDC MIMO FFT/IFFT architecture, at each pipeline stage only one butterfly can be used [1]. However, proper scheduling and data reordering the input data of  $N_s$  streams is required. The radix of the butterfly employed in the FFT/IFFT architecture influence the hardware complexity. A butterfly with smaller radix simple in structure. On the other hand, to reduce the twiddle factor multiplications a high radix butterfly may be adopted. An MDC FFT/IFFT architecture is designed using radix- $2^k$  butterfly [24]. In [11], [15], [25-27] [29], the design of multi-path pipelined FFT processors provides a high throughput is reported. Nevertheless, for high throughput applications with a rate of over 2 GS/s throughput, the data-paths can be increased to eight or sixteen, results in increased hardware cost. To reduce the area and power consumption numerous FFT algorithms and schemes for dynamic scaling are presented in [15], [25-27]. Radix  $2^4$  FFT algorithm and architecture are proposed to reduce the number of complex multipliers. In [13], reduction of twiddle coefficient multiplications and to attain a simple butterfly concurrently, the radix  $r^k$  algorithms are suggested. Though the radix-2 based FFT processor is simple in structure, it involves many complex multipliers. The radix-4 based FFT



processor offers high throughput, but it results in high complexity [10].

Spectrum of real sample inputs viz. biomedical, speech, RADAR, audio signals and images is symmetric and nearly half the operations are redundant.

Table-1 Summary of various MIMO OFDM FFT/IFFT architectures reported in the literature

	Algorithm	Structure	FFT/IFFT Length	Application
[1]	Radix-4 and Radix-8	MDC	2048/1024/512/128	IEEE 802.16 Wi MAX and 3GPP LTE
[54]	Modified radix-2 <sup>5</sup>	MDF and MDC	512	WPAN
[55]	Radix-3, radix-2/4/8	SDF	128 to 2048/1536	Wi MAX
[47]	Radix-8, radix-4, radix-2	MDC	512/256/128/64	IEEE 802.11ac
[15]	Radix-2 <sup>4</sup> , radix-2 <sup>3</sup>	MDF	2048/128	WPAN
[19]	Radix-2 <sup>4</sup>	MDF	128/64	MB OFDM
[11]	Mixed radix	MRMDF	128	UWB
[17]	Mixed radix	8PBF	128/64	UWB
[25]	Radix-2 <sup>4</sup>	SDF	128	MB-OFDM UWB
[26]	Indexed Scaling	MRMDF	2048	WPAN
[56]	Mixed radix	MRMDC	64/128	IEEE 802.11n WLAN

Few pipelined architectures for real valued signals have been proposed [42], [43] based on the Brunn algorithm but are not popular, since it was demonstrated [44] that the noise is significantly higher than that in the Cooley–Tukey algorithm. Different algorithms are proposed for RFFT computation in [42], [43], [45]. But these algorithms are efficiently used in a digital signal processor when compared to a specific hardware implementation. CFFT presented in [46] computes two RFFTs concurrently. The packing algorithm presented in [46] forms a complex sequence of length N/2 by taking even and odd indexed samples in real input sequence of length N, and computes the N/2-point CFFT of the complex sequence.

A variable length FFT/IFFT processor for IEEE 802.11ac compliant MIMO OFDM system is reported in [47] Various FFT/IFFT architectures reported in the literature for different applications are summarized in Table 1. The 802.11ac [48-50] compliant FFT/IFFT processor requirements [58] are shown in

Table 2.[58] This standard Wi Fi technology supports more spatial streams up to eight, multi-user MIMO and wider channels High data rates up to 6.93 Gbps [58].

Table- 1 Few features of IEEE 802.11ac standard related to OFDM processing.

S. No.	Feature	Mandatory	Optional
1.	Channel Bandwidth	20 MHz, 40 MHz, 80 MHz	160 MHz, 80+80 MHz
2.	FFT Size	64,128,256	512
3.	Data subcarriers/Pilots	52/4, 108/6, 234/8	468/16
4.	Spatial streams and MIMO	1	2 to 8
5.	Modulation types	BPSK,QPSK,16QAM,64QAM	256QAM
6.	Operating mode	Very high throughput	---
7.	*MCS supported	0 to 7	8 and 9

\*Modulation and Coding Schemes[58]

Pre- and post- transformed data reordering is crucial in a pipelined FFT/IFFT processor for multiple data streams. The pre- and post- transform data reordering methodologies for handling multiple data streams up to eight is presented in [57][58].

### III. COMPARISON AND ANALYSIS

The parallel feedback architectures of radix-2<sup>4</sup> [16], [20] saved 50% of the adders and reduced the requirements of memory, while maintaining the same number of rotors when compared with the designs of radix-2<sup>4</sup> [24]. Among the 4-parallel architectures reported in the literature [24], the radix 2<sup>2</sup> feed forward FFT[51] and the radix-4 feed forward FFT [37], [52], require the lower number of adders, rotators, and memory. Even though the architectures of radix-2<sup>2</sup> and radix-4 require the same quantity of hardware resources for 4-parallel samples, these resources possess different layouts.Radix-2<sup>2</sup> concedes the circuits for data management and rotators between radix-2 butterflies, where in radix-4, pairs of successive sets of radix-2 butterflies must essentially be together in order to form the radix-4 butterfly [24].

Comparing the architectures of 4-parallel radix-2<sup>3</sup> and radix-2<sup>4</sup> with the architecture of 4-parallel radix-4 feed forward FFT [18], [52], it is observed that radix-2<sup>3</sup> and radix-2<sup>4</sup> need the same number of adders and the same size of memory, but need less number of general rotators [24]. Furthermore, 4-parallel radix-2<sup>4</sup> feed forward FFT [24] saves 50% of the adders and 25% of the rotators as compared to radix 2<sup>4</sup> parallel feedback architectures [16], [20]. The 8-parallel radix-2<sup>2</sup> feed forward



FFT [24] have the capacity to save the number of rotators by 25% compared to radix-2 feed forward FFTs [53], adders by 50% and rotators by 25% with regard to feedback architectures [14].

Table- 3 Hardware resources for the given M-channel MIMO

Topology	No. of Butterflies	Complex multipliers	Complex Adders
Radix-2 MDC	$\lceil M/2 \rceil$	$\log_2 N - 2$	$2 \cdot \log_2 N$
Radix-4 MDC	$\lceil M/4 \rceil$	$3 \cdot (\log_4 N - 1)$	$8 \cdot \log_2 N$
Radix-8 MDC	$\lceil M/8 \rceil$	$7 \cdot (\log_8 N - 1)$	$(24 + 2TM) \cdot \log_8 N$
Radix-2 SDF	M	$\log_2 N - 1$	$2 \cdot \log_2 N$
Radix-4 SDF	M	$\log_4 N - 1$	$8 \cdot \log_4 N - 1$

\*TM: Trial multipliers [10]

The hardware complexity comparison of various pipeline structures [10] are compared in Table 3. Here, it can be observed that the radix-8 MDC is preferred structured for the FFT/IFFT for eight data stream applications. The hardware complexity of radix-R MDC is shared by R streams while the complexity of other structures is increased with the number of spatial streams [10].

#### IV. CONCLUSION

In this paper, the FFT/IFFT architectures aimed for various wireless technologies such as IEEE 802.11ac, IEEE 802.11n, WPAN, UWB, WiMAX reported in the literature for OFDM applications are reviewed and compared. The hardware complexity of various pipelined structures are compared. It is observed that the radix-R MDC FFT/IFFT for R×R MIMO-OFDM is more area efficient compared to other possible topologies. The radix-2<sup>k</sup> butterfly offers the structural simplicity and optimized hardware complexity.

#### V. REFERENCES

[1] Kai-Jiun Yang, Shang-Ho Tsai, Senior Member, IEEE, and Gene C. H. Chuang, Member, IEEE, "MDC FFT/IFFT Processor With Variable Length for MIMO-OFDM Systems", IEEE Transactions on Very Large Scale Integration (VLSI) Systems, Vol. 21, No. 4, April 2013  
 [2] Asymmetric Digital Subscriber Line Transceivers 2 (ADSL2), ITU-T Standard G.992.3, Jan. 2005.

[3] Very-High-Bit-Rate Digital Subscriber Line Transceiver 2 (VDSL2), ITUT Standard G.993.2, Feb. 2006.  
 [4] The Wireless LAN Media Access Control (MAC) and Physical Layer (PHY) Specifications, IEEE Standard 802.11, 1999.  
 [5] IEEE Standard for Local and Metropolitan Area Networks. Part16: Air Interface for Fixed Broadband Wireless Access Systems, IEEE Standard 802.16-2004, Oct. 2004.  
 [6] IEEE Standard for Local and Metropolitan Area Networks. Part16: Air Interface for Fixed Broadband Wireless Access Systems, IEEE Standard 802.16e-2005, Feb. 2006.  
 [7] Y. G. Li, J. H. Winters, and N. R. Sollenberger, "MIMO-OFDM for wireless communications: Signal detection with enhanced channel estimation," IEEE Trans. Commun., vol. 50, no. 9, pp. 1471–1477, Sep. 2002.  
 [8] B. G. Jo and M. H. Sunwoo, "New continuous-flow mixed-radix (CFMR) FFT processor using novel in-place strategy," IEEE Trans. Circuits Syst. I, Reg. Papers, vol. 52, no. 5, pp. 911–919, May 2005.  
 [9] P. Y. Tsai and C. Y. Lin, "A generalized conflict-free memory addressing scheme for continuous-flow parallel-processing FFT processors with rescheduling," IEEE Trans. Very Large Scale Integr. (VLSI) Syst., vol. 19, no. 12, pp. 2290–2302, Dec. 2011.  
 [10] T. Sansaloni, A. Perex-Pascual, V. Torres, and J. Valls, "Efficient pipeline FFT processors for WLAN MIMO-OFDM systems," Electron. Lett., vol. 41, no. 19, pp. 1043–1044, Sep. 2005.  
 [11] Y.-W. Lin, H.-Y. Liu, and C.-Y. Lee, "A 1-GS/s FFT/IFFT processor for UWB applications," IEEE J. Solid-State Circuits, vol. 40, no. 8, pp. 1726–1735, Aug. 2005.  
 [12] Y.-W. Lin and C.-Y. Lee, "Design of an FFT/IFFT processor for MIMO OFDM systems," IEEE Trans. Circuits Syst. I, Reg. Papers, vol. 54, no. 4, pp. 807–815, Apr. 2007.  
 [13] A. Cortés, I. Vélez, and J. F. Sevillano, "Radix r<sup>k</sup> FFTs: Matricial representation and SDC/SDF pipeline implementation," IEEE Trans. Signal Process., vol. 57, no. 7, pp. 2824–2839, Jul. 2009.  
 [14] E. H. Wold and A. M. Despain, "Pipeline and parallel-pipeline FFT processors for VLSI implementations," IEEE Trans. Comput., vol. C-33, no. 5, pp. 414–426, May 1984.  
 [15] S.-N. Tang, J.-W. Tsai, and T.-Y. Chang, "A 2.4-GS/s FFT processor for OFDM-based WPAN applications," IEEE Trans. Circuits Syst. I, Reg. Papers, vol. 57, no. 6, pp. 451–455, Jun. 2010.  
 [16] H. Liu and H. Lee, "A high performance four-parallel 128/64-point radix- FFT/IFFT processor for MIMO-OFDM systems," in Proc. IEEE Asia Pacific Conf. Circuits Syst., 2008, pp. 834–837.  
 [17] L. Liu, J. Ren, X. Wang, and F. Ye, "Design of low-power, 1 GS/s throughput FFT processor for MIMO-OFDM UWB communication system," in Proc. IEEE Int. Symp. Circuits Syst., 2007, pp. 2594–2597.



- [18] J. Lee, H. Lee, S. I. Cho, and S.-S. Choi, "A high-speed, low-complexity radix-2<sup>4</sup> FFT processor for MB-OFDM UWB systems," in Proc. IEEE Int. Symp. Circuits Syst., 2006, pp. 210–213.
- [19] N. Li and N. P. van der Meijs, "A radix 2<sup>2</sup> based parallel pipeline FFT processor for MB-OFDM UWB system," in Proc. IEEE Int. SOC Conf., 2009, pp. 383–386.
- [20] S.-I. Cho, K.-M. Kang, and S.-S. Choi, "Implementation of 128-point fast Fourier transform processor for UWB systems," in Proc. Int. Wirel. Commun. Mobile Comput. Conf., 2008, pp. 210–213.
- [21] S. He and M. Torkelson, "Design and implementation of a 1024-point pipeline FFT processor," in Proc. IEEE Custom Integr. Circuits Conf., 1998, pp. 131–134.
- [22] M. Garrido, "Efficient hardware architectures for the computation of the FFT and other related signal processing algorithms in real time," Ph.D. dissertation, Dept. Signals, Syst., Radio commun., Univ. Politécnic Madrid, Madrid, Spain, 2009.
- [23] Y. Jung, H. Yoon, and J. Kim, "New efficient FFT algorithm and pipeline implementation results for OFDM/DMT applications," IEEE Trans. Consumer Electron., vol. 49, no. 1, pp. 14–20, Feb. 2003.
- [24] Mario Garrido, Member, IEEE, J. Grajal, M. A. Sánchez, and Oscar Gustafsson, Senior Member, IEEE, "Pipelined Radix-2<sup>k</sup> Feed forward FFT Architectures", IEEE Transactions on Very Large Scale Integration (VLSI) Systems, Vol. 21, no. 1, January 2013.
- [25] J. Lee and H. Lee, "A high-speed two-parallel radix-2<sup>4</sup> FFT/IFFT processor for MB-OFDM UWB systems," IEICE Trans. Fundam., vol. E91-A, no. 4, pp. 1206–1211, Apr. 2008.
- [26] Y. Chen, Y. Tsao, Y. Wei, C. Lin, and C. Lee, "An indexed-scaling pipelined FFT processor for OFDM-based WPAN applications," IEEE Trans. Circuits Syst. II, Exp. Briefs, vol. 55, no. 2, pp. 146–150, Feb. 2008.
- [27] M. Shin and H. Lee, "A high-speed four-parallel radix-2<sup>4</sup> FFT processor for UWB applications," in Proc. IEEE Int. Symp. Circuits Syst. (ISCAS), 2008, pp. 960–963.
- [28] S. Huang and S. Chen, "A green FFT processor with 2.5-GS/s for IEEE 802.15.3c (WPANs)," in Proc. Int. Conf. Green Circuits Syst. (ICGCS), 2010, pp. 9–13.
- [29] T. Cho, H. Lee, J. Park, and C. Park, "A high-speed low-complexity modified FFT processor for gigabit WPAN applications," in Proc. IEEE Int. Symp. Circuits Syst. (ISCAS), 2011, pp. 1259–1262.
- [30] M. Garrido, K. K. Parhi, and J. Grajal, "A pipelined FFT architecture for real-valued signals," IEEE Trans. Circuits Syst. I, Reg. Papers, vol. 56, no. 12, pp. 2634–2643, Dec. 2009.
- [31] Manas Ranjan Meher, Member, IEEE, Ching Chuen Jong, and Chip-Hong Chang, Senior Member, IEEE, "An Area and Energy Efficient Inner-Product Processor for Serial-Link Bus Architecture", IEEE Transactions on Circuits and Systems—I: Regular Papers, Vol. 59, No. 12, December 2012.
- [32] J. W. Cooley and J. Tukey, "An algorithm for machine calculation of complex Fourier series," Math. Comput., vol. 19, pp. 297–301, Apr. 1965.
- [33] A. V. Oppenheim, R.W. Schaffer, and J.R. Buck, Discrete-Time Signal Processing, 2nd ed. Englewood Cliffs, NJ: Prentice-Hall, 1998.
- [34] P. Duhamel, "Implementation of split-radix FFT algorithms for complex, real, and real-symmetric data," IEEE Trans. Acoust., Speech, Signal Process., vol. 34, no. 2, pp. 285–295, Apr. 1986.
- [35] L. R. Rabiner and B. Gold, Theory and Application of Digital Signal Processing. Englewood Cliffs, NJ: Prentice-Hall, 1975.
- [36] A. M. Despain, "Fourier transform using CORDIC iterations," IEEE Trans. Comput., vol. C-233, no. 10, pp. 993–1001, Oct. 1974.
- [37] E. E. Swartzlander, W. K. W. Young, and S. J. Joseph, "A radix-4 delay commutator for fast Fourier transform processor implementation," IEEE J. Solid-State Circuits, vol. SC-19, no. 5, pp. 702–709, Oct. 1984.
- [38] E. E. Swartzlander, V. K. Jain, and H. Hikawa, "A radix-8 wafer scale FFT processor," J. VLSI Signal Process., vol. 4, no. 2/3, pp. 165–176, May 1992.
- [39] G. Bi and E. V. Jones, "A pipelined FFT processor for word-sequential data," IEEE Trans. Acoust., Speech, Signal Process., vol. 37, no. 12, pp. 1982–1985, Dec. 1989.
- [40] J. Lee, H. Lee, S. I. Cho, and S. S. Choi, "A High-Speed two parallel radix- FFT/IFFT processor for MB-OFDM UWB systems," in Proc. IEEE Int. Symp. Circuits Syst., 2006, pp. 4719–4722.
- [41] J. Palmer and B. Nelson, "A parallel FFT architecture for FPGAs," Lecture Notes Comput. Sci., vol. 3203, pp. 948–953, 2004.
- [42] R. Storn, "A novel radix-2 pipeline architecture for the computation of the DFT," in Proc. IEEE ISCAS, 1988, pp. 1899–1902.
- [43] Y. Wu, "New FFT structures based on the Bruun algorithm," IEEE Trans. Acoust., Speech Signal Process., vol. 38, no. 1, pp. 188–191, Jan. 1990.
- [44] R. Storn, "Some results in fixed point error analysis of the Bruun-FFT algorithm," IEEE Trans. Signal Process., vol. 41, no. 7, pp. 2371–2375, Jul. 1993.
- [45] B. R. Sekhar and K. M. M. Prabhu, "Radix-2 decimation in frequency algorithm for the computation of the real-valued FFT," IEEE Trans. Signal Process., vol. 47, no. 4, pp. 1181–1184, Apr. 1999.
- [46] W.W. Smith and J. M. Smith, Handbook of Real-Time Fast Fourier Transforms. Piscataway, NJ: Wiley-IEEE Press, 1995.
- [47] Govinda Locharla, Kamala Mahapatra, Samit Ari, "Variable Length Mixed Radix MDC FFT/IFFT Processor for OFDM Application", IET Computers & Digital Techniques, doi: 10.1049/iet-cdt.2017.0018, Sept. 2017.



- [48] '802.11ac: The Fifth Generation of Wi-Fi Technical White Paper', Cisco, [www.cisco.com](http://www.cisco.com), 2014.
- [49] 'IEEE 802.11ac 5 GHz Wireless Update and Structured Cabling Implications', Siemon, [www.siemon.com](http://www.siemon.com), 2014.
- [50] IEEE Standard for Information technology - Telecommunications and information exchange between systems Local and metropolitan area networks - Specific requirements - Part 11: 'Wireless LAN Medium Access Control (MAC) and Physical Layer (PHY) Specifications - Amendment 4: Enhancements for Very High Throughput for Operation in Bands below 6 GHz', 2013.
- [51] P. A. Milder, F. Franchetti, J. C. Hoe, and M. Puschel, "Formal data path representation and manipulation for implementing DSP transforms," in Proc. IEEE Design Automation Conf., Jul. 2008, pp. 385–390.
- [52] J. H. Mc Clellan and R. J. Purdy, Applications of Digital Signal Processing. Prentice-Hall, 1978, Ch. 5, Applications of Digital Signal Processing to Radar.
- [53] J. A. Johnston, "Parallel pipeline fast Fourier transformer," in IEE Proc. F Comm. Radar Signal Process., vol. 130, no. 6, Oct. 1983, pp. 564– 572.
- [54] Cho, Taesang, and Hanho Lee. "A High-Speed Low-Complexity Modified Radix-2<sup>5</sup> FFT Processor for High Rate WPAN Applications." IEEE Transactions on Very Large Scale Integration (VLSI) Systems 21.1, 2013: 187-191.
- [55] Yu, Chu, and Mao-Hsu Yen. "Area-efficient 128-to 2048/1536-point pipeline FFT processor for LTE and mobile WiMAX systems." IEEE Transactions on Very Large Scale Integration (VLSI) Systems 23.9 (2015): 1793-1800.
- [56] Kang, Byungcheol, and Jaeseok Kim. "Low complexity multi-point 4-channel FFT processor for IEEE 802.11 n MIMO-OFDM WLAN system." Green and Ubiquitous Technology (GUT), 2012 International Conference on. IEEE, 2012.
- [57] Locharla, Govinda Rao, et al. "Implementation of MIMO data reordering and scheduling methodologies for eight-parallel variable length multi-path delay commutator FFT/IFFT." IET Computers & Digital Techniques 10.5 (2016): 215-225.
- [58] <http://www.radio-electronics.com/info/wireless/wi-fi/ieee-802-11ac-gigabit.php>, <http://www.radio-electronics.com>, 2017.

# IJEAST

INTERNATIONAL JOURNAL  
OF ENGINEERING APPLIED SCIENCE  
AND TECHNOLOGY

## ABOUT IJEAST

International Journal of Engineering Applied Science and Technology (IJEAST) is a peer-reviewed, open access journal that publishes high-quality research papers in the field of Engineering, Applied Science and Technology.

IJEAST aims to provide a platform for researchers, academicians, and professionals to share their innovative ideas, research findings, and practical experiences with the global scientific community.

## FOCUS AREAS

- Engineering
- Applied Science
- Technology
- Innovation & Development
- Interdisciplinary Studies



### PEER REVIEWED

All submissions are rigorously peer reviewed to ensure quality.



### OPEN ACCESS

Free and unrestricted access to research for all.



### GLOBAL REACH

Connecting researchers and professionals worldwide.



### TIMELY PUBLICATION

We ensure a swift and efficient publication process.



For more information, visit our website

[www.ijeast.com](http://www.ijeast.com)



INTERNATIONAL JOURNAL  
OF ENGINEERING APPLIED SCIENCE  
AND TECHNOLOGY

✉ [editor@ijeast.com](mailto:editor@ijeast.com)

🌐 [www.ijeast.com](http://www.ijeast.com)

📍 India



2455-2143