



IJEAST

INTERNATIONAL JOURNAL
OF ENGINEERING APPLIED SCIENCE
AND TECHNOLOGY



VOLUME : 5 ISSUE : 1 Print / Issue Publication Date: 29-Jul-2020



ISSN : 2455-2143



DOI : 10.33564/IJEAST.2020.v05i01.128

Indexed In



WWW.IJEAST.COM

editor@ijeast.com

AN EXTENSIVE REVIEW STUDY OF FRICTION STIR WELDING TOOLS AND ITS SPECIFICATIONS.

AZAM IQBAL 1, ER. GURU SEWAK KESHARWANI², PROF.DR. RAVISH KUMAR SRIVASTAVA³

1 M. Tech. Scholar (Production Engineering), New Delhi

2 Assistant Professor, Department of Mechanical Engineering, Meerut, U.P.

3 Head of Department, Department of Mechanical Engineering, S.I.T.E, Swami Vivekanand Subharti University, Meerut 250005, India.

ABSTRACT — Year 1991, Friction stir welding (FSW) emerge as solid state joining technique. The fundamental approach of FSW is simple. A circumvolving tool with a uniquely designed probe (pin) and shoulder is plunged into the touching edges of the work piece and traversed along the weld line. The edged of workpiece gain frictional heating and plasticized and the shoulder downward pressure reinforce the trailing material. FSW is a smokeless and low energy consuming process, no fillet material, no welding weight gain, high tensile strength, and high weld quality, fast welding process, save operation time, no corrosion, and long life cycle marked as green technology. FSW is operated under the liquefying temperature of the material, minim material deformity as cracking, porosity. FSW is a constructive joining technique for Aluminum and alloys. The aspect of FSW tools are to generate heat on workpiece, influence material flow and drive plasticized metal beneath shoulder. Frictional heat generated by circumvolving shoulder tool pin with the workpiece and by the plastic deformation of the metal in the workpiece. The localized stirring softens the material around the probe. The tool rotation and translation make material movement from front to back probe. [1]

The tool shoulder also restricts the metal flow under the bottom shoulder surface. The diverse geometrical details of tools cause material shift around probe can be excessively complicated and naturally distant from one tool to another one. Friction stir welding acknowledge most symbolic engineering for metal joining in the past decades.

KEY WORDS - FSW tools, Tools, Dimension, Process design, Type, geometry, Shape, Size, Material selection, Specifications,

I. INTRODUCTION

A friction stir welding tool is indeed influential integral component for weld operation of piece. Tool with cylindrical threaded pin move around plasticized stirred material by frictional heat generation on work piece when circular disk shape shoulder circumsolve. There might be some defects like solidification cracking, porosity, volatile element loss are avoided although no bulk melting of work piece. Tool pin yield high temperature, severe stress, non-consumable, economical operation, although hard work piece material may affect tool pin.

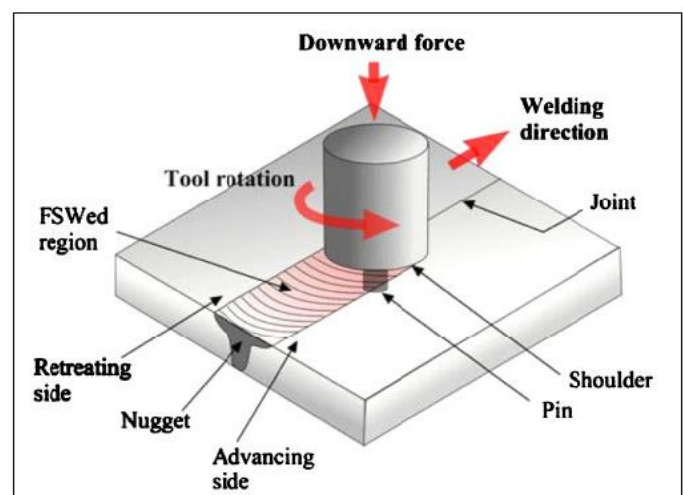

Fig.1 Friction Stir Welding Tool movement.

Tool material like steel and titanium alloy may be a higher cost, although research are continued for cost effective material for tools manufacturing considering for reusable product, high strength, cost cut and empirical by nature. Although significant efforts have been made in the recent past to develop cost effective and reusable tools, most of the efforts

have been empirical in nature, improved designed and practical for weld operation. This review paper focus on tool geometry, issues of material selection, microstructure, load bearing ability, failure mechanisms and process economics, Shoulder design, tool characteristics etc.



Fig.2 Cylindrical and Conical tools shape

These advantages are the main reasons for its widespread commercial success for the welding of aluminum and other soft alloys.

II. LITERATURE REVIEW

Tool is most important component for the joining process. The tool selection is very crucial and selected intelligently and by experienced engineer. Tool uses are non-consumable and have a high resistance value. Tool used must have high stress strength, have high thermal resistance value. Tool design must have high efficiency and operator friendly. Some major principle tool in welding process.

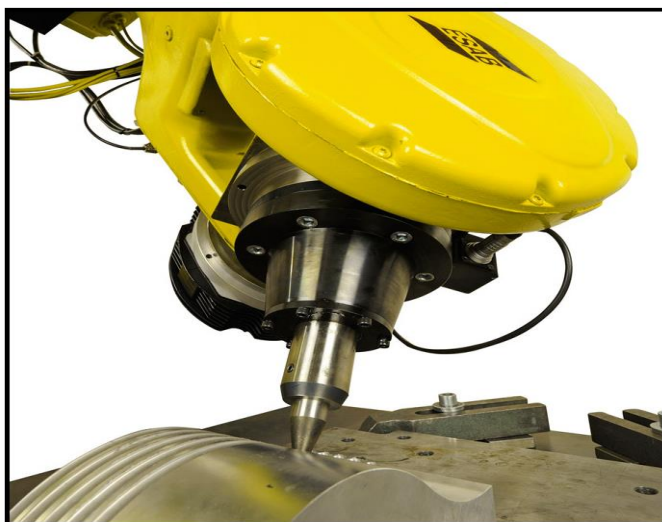

Fig.3 Robotic friendly tool.

Friction Welding Tools Processes Methodology.

Tool pin is the part which indulge in to material or work piece and stir midway edges of work piece to weld. The stir friction welding pin starting at a zero penetration and extending to depth needed to repair a weld or to make a weld. Then withdrawing the pin at zero penetration as the work is translated. The weld path is thus ramped into and out of work

piece leaving no holes which need to be repaired. Circumferential welds can be made keeping the pin extended to the welding path for at least one complete revolution of weld. [1]

There are three major steps in friction stir welding as,

Plunging – Plunging is o of localized indulging into the work piece and making a worm hole in work piece. it is done in two stages as a hole is pierced in the work at required position by tool pin, the pierced hole in work piece is shape and height of pin of tool.

Bonding – The tool pin stir edges of work piece and plasticize material and these discharge plasticized metal back to mix together in the groove and make a bonding on solidification of the materials. This process is known as bonding of metal.

Drawing out – The tool pin is inserted into work piece is drawn out leaving a hole of pin size and height. The pin hole is the drawback of friction stir welding.

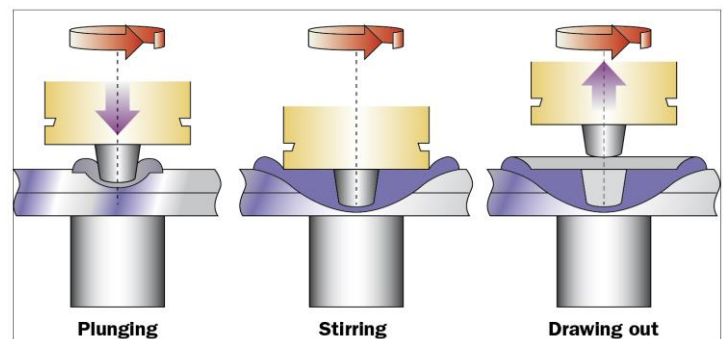

Fig.4 Tool processing steps.

III. TOOLS INVESTIGATION

A. Tool Type

FSW tools has three type as fixed, adjustable and self-reacting. The fixed probe tool coincide to a single piece contain shoulder and probe. Fixed tool can only weld a workpiece with a stable thickness due to fixed probe length, the whole tool replaced if any tool defect caused. In case of fixed tool for friction stir spot welding, tool contain only a single shoulder with no probe was noticed. The adjustable tool contain of two self-reliant pieces, i.e. separate shoulder and probe, to allow adjustable of probe length in course of operation. In this adjustable tools, the shoulder and probe can be designed using distinct materials and the probe can be easily restored when worn or damaged.

Moreover, the adjustable probe length can let joining of variable as well as multiple gauge thickness workpieces, and employment of strategies for dressing exit worm hole, at plunge out. A backing anvil need for both fixed and the adjustable tools, where bobbin type tool is made up of three pieces: top shoulder, probe and bottom shoulder, which hold multiple gauge thickness joints due to the

adjustable probe length between top and bottom shoulders. Since bobbin type tool work perpendicularly to the workpiece surface therefore no backing anvil is required. In contrast, fixed and adjustable tools are tilted longitudinally and laterally.[10]

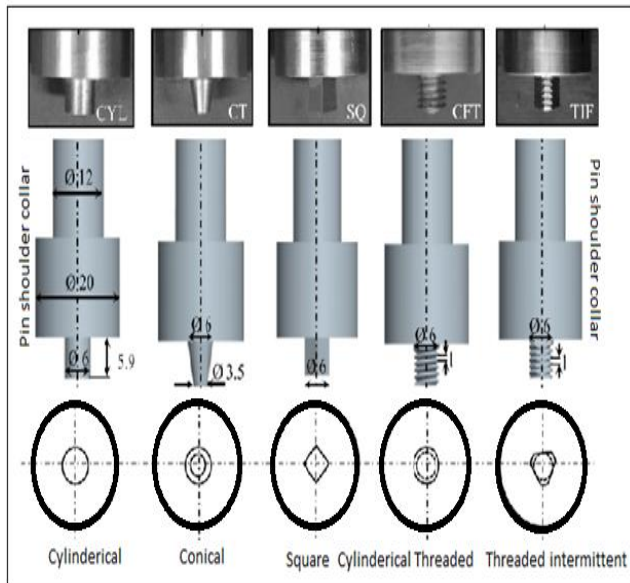

Fig.5 Different typed of tool design.

B. Tool Dimensions:

As generated frictional heat absorption is a function of shoulder radius to the third power however calculated only linearly on the applied forge force and rotational speed.

Thus, the energy admission in welding is strongly dependent on shoulder size. [10]

$$q_0 \sim 4 = 3p^2 m P v R^3 \quad \dots \text{equation (1)}$$

q_0 is the net power (W),

m is effective friction coefficient between workpiece and tool

P is the pressure (MPa),

v is the rotation speed (rev min⁻¹),

R is shoulder radius (mm).

Aircraft engine manufacturing, friction welding operating tools if material nickel and cobalt alloys designed high strength, high ductility, high creep value and great corrosion resistance. Tools are totally robotic machining and welder friendly. Tungsten, Molybdenum, Niobium and Tantalum tool of high temperature bearing material, and high tensile strength value. Carbide offer wear resistance and fracture toughness used for machining tools. Polycrystalline cubic boron nitride for turning and machining of steel, cast iron and super alloy tools has thermal performance and high machining.

C. Tool shapes / Shoulder shapes

Designing tool surface to generate frictional heat on work piece decide welding specifications, produce downward force for forging and solidification and strained heated metal beneath shoulder's bottom surface. Shoulder outmost surface mostly have a cylindrical shape, either conical surface used infrequently. Shape of shoulder outmost surface either cylindrical or conical has minimal impact on the welding

quality as the shoulder plunge depth is consistently small nearly 1–10 % of the gauge thickness. Top surface during joining operation at higher feed ratio, stirred material get regularly trapped in the cavity beneath shoulder. Concave shoulder connected with a scrolled character can minimize the tool drive during high. Further benefits of the scrolled shoulder is the eradication of the tunnel defect formed by the concave tool. Precise coupling between shoulder and work-piece by entrapping plasticized material within special restraint component. [10]

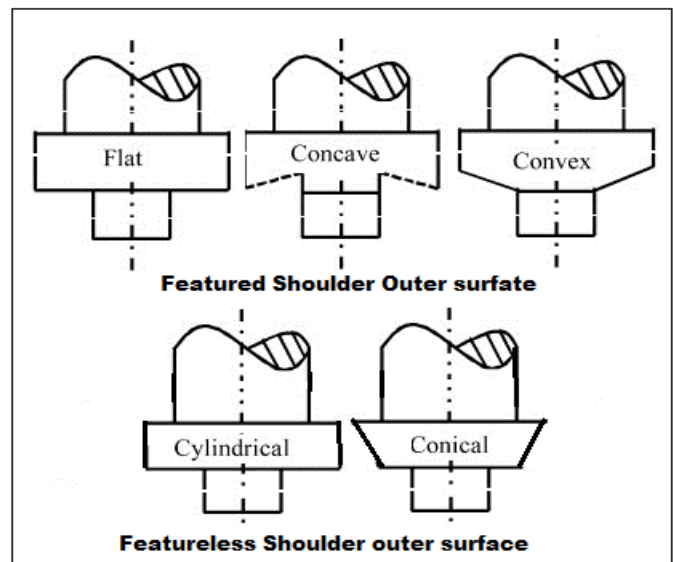

Fig.6 Different Shoulder outer surface.

Shoulder along convex shoulder design halt material shift away from probe and yield benefits of higher flexibility in contact area among shoulder and workpiece, Shoulder with flat surface is simplest design has demerits of not efficient to entrap the material flow beneath shoulder, cause extra material flash. Thus concave shoulder is exceeding for restricting material extrusion roundabout shoulder, Concave shoulder tilt small angle from flat shoulder end surface. At plunging, the material moved by probe is fed into tool shoulder cavity. Thus concave surface tool geometry deliver as reservoir for displaced material from probe. Downward force of tool lead to displace material held in concave shoulder profile provide a forging activity on material behind tool. Tool is tilted with a certain angle for proper operation of tool on work piece. [10]

This is necessary to maintain the material reservoir and to enable the trailing edge of the shoulder tool to produce a compressive forging force on the weld. Higher forging and hydrostatic pressures boost material stirring and enriched nugget integrity. Primary benefits of convex shoulder profile is that it secure contact with workpiece at all location along the convex end surface, manage irregularity in flatness either thickness between the two connecting workpieces. Shoulder end styles are flat, scrolls, ridges, knurling, grooves and concentric circles and other features enforce concave, flat or convex shoulder ends, where Scrolls are generally used shoulder

feature. Scrolled shoulder contain a flat end surface with a spiral medium cleavage from edge towards center. It help material flow from edge of shoulder to probe, thus reduce tools tilt angle where concave polished shoulder end tends to be shift away from the workpiece.

D. Probe shapes

Tool stirring pin yield generate frictional heating and deform work piece edges. Tool designed to unsettle and stir connecting edges of work piece, stir front material of tool and material move behind the tool. The interjection of pin height equal to deformation intensity and tool feed ratio of probe. Probe is flat either domed at end. Flat probe easy design and easy manufacture, most common used by welder. A flat probe has high forge force at plunging where domed or round shape tool decline forge force. Elimination of local stress concentration enhance and exterminate weld root at probe bottom, when tool wore at plunging and bonding metal.

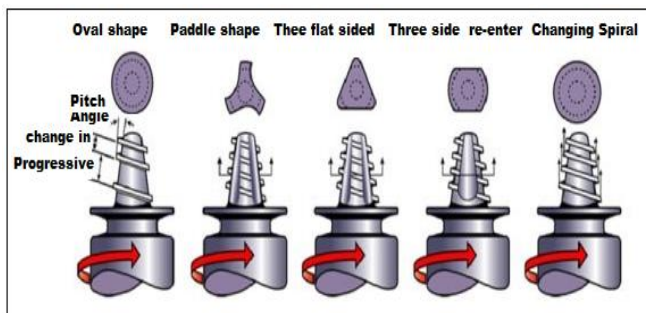

Fig.7 Different probe shape.

As dome shape tool radius decreases, the weld quality was often comprised and dome shape tool radius maximized high weld quality as surface velocity of rotating cylinder as surface velocity of rotating cylinder accelerate high to speed at edges. Higher circumvolving of probe increase stirring rate to metal flow rate, where round smooth shape pin have least stirring rate, cylindrical shape pin is usual and low feed ratio with high circumvolving speed preserve weld integrity of operation.

Higher frictional heat enhance stirring rate and plasticized work piece. High hydrostatic pressure in weld zone excessively enhancing material stirring and clear nugget integrity. Without threaded probes are of material for high strength as threaded tool. Stirred material circulate various times around tool afore deposition trailing tool boost material stirring, oxide breakdown, void closure. It increases material elasticity and turbulent flow decline transverse force, tool torque proportional to flat placed. Without threaded tool create tunnel effect as no tunnel found in non-threaded. Tool weld with high speed achieve integral weld with high surface quality.

E. Tool geometry

Tool geometry influence the heat generation rate, torque thermo-mechanical environment, circumvolving speed, traverse force, feed ratio. Plasticized stirred material flow in workpiece influence tool design and linear and rotational drift of tool. Influential factors are shoulder surface angle, shoulder diameter, pin design, pin shape and size, and nature of tool surfaces.

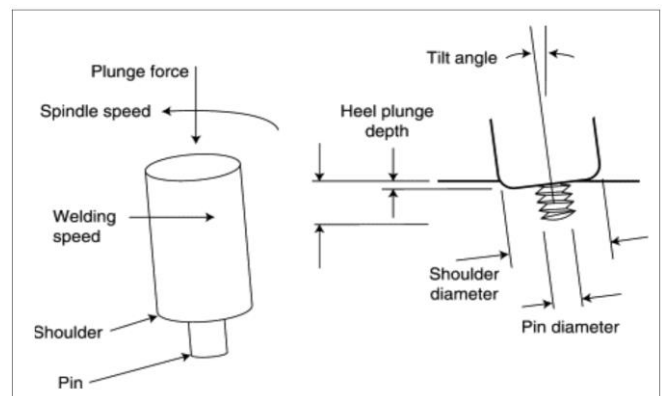

Fig.8 Tool geometry.

F. Shoulder diameter

Shoulder diameter is influential as shoulder generates most of heat, embrace plasticized materials. Both drift and stirring produce frictional heat while material flow induced by stirring. For better weld result, the material should be adeptly plasticized softened to flow and tool must adeptly enclose plasticized material where total torque and traverse force should not be over gain

G. Pin (probe) geometry

Tool pin (or probe) shape and size impact on plasticized material flow and influence weld specifications. As tool shoulder facile large material flow, pin encourage a layer by layer material flow and form onion ring. A 'trifluted' tool (triangular shape) pin enhance the material flow rate with respect to cylindrical shape, and triangular prism pin nearby

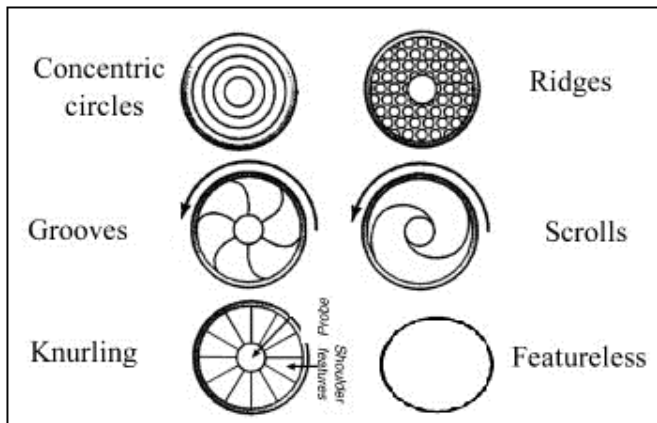

Fig.9 Probe (pin) Geometry.

tools are affected by orientation of threads on pin surface. They suggested that a triangular prism shaped tool pin would be advisable for harder alloys such as AA 5083, 7000 series. Columnar and tapered, both with and without threads observed tapered pin profile with screw thread produced high welds quality.

H. Other tools

Si₃N₄ used for cutting tool material as it has higher hardness, low coefficient of thermal expansion, high thermal conductivity and contain rare property. TiC has high temperature wear resistance can result in further improvements as coated with inactive material such as diamonds. In DP590 steel along Si₃N₄ tools noticed as O and N filth leads to formation of finer martensite. Excessive heat from tool reduced by water cooling, for successful workpiece joining of titanium metal by using TiC welding tool, where Molybdenum based alloy are used to weld AISI 1018 mild steel 75 and Ti-15V-3Cr-3Al-3Sn alloy.



Fig.10 some tools pin of various design.

I. Tool material selection

Fictional heat generation and dissipation decide the properties of joining where tool wear and welding quality are considered while selecting tool material and contact with damaged tool material leads to affect weld microstructure. Cost of operation may go higher when unwanted output on weld microstructure appear and decline tool potential. Eroded tool has low strength at high temperature as stress on tool pin calculated by fatigue durability of workpiece at higher temperature. Temperatures in the workpiece depend on the material properties of tool, such as thermal conductivity, for a given workpiece and processing

parameters. Tool pin material characteristics like thermal conductivity, material hardness, and fatigue strength etc. figure frictional heat temperature develop on work piece while joining operation process where thermal stresses in tool may be affected by coefficient of thermal expansion.

J. Process parameter tool frame work.

Process parameter frame work.	
Tool Design	Weld Quality , Securing maximal accessible welding speed, Pre-strong, tough and hard wearing, High welding temperature.
Tool Rotational Speed	Solid state joining process Process between tool pin profile and plate. Friction generation depends on Rotational speed. Rotational speed increase or decrease weld quality will likely to increase or decrease accordingly.
Welding Feed Speed-	Temperature decreases when an increase in welding speed the temperature at local position. When there is slow feed speed the temperature increases.
Axial Force-	Lead, Copper and its alloys, Titanium and its alloys, Magnesium alloys, Zinc, Plastics, Mild steel, Stainless Steel, Nickel Alloys.

Table.1 Tool process frame work.

K. Tool material characteristics

Selecting the correct tool material requires knowing which material characteristics are important for each friction stir application. Many different material characteristics could be considered important to friction stir welding process.

Material specification of tool is essential assist to select right material for tool pin, which is important for operation. Tool material decide the quality of welding properties. Some significant point to consider for tool material selection. [7]

- Machinability
- Tool Reactivity
- Wear Resistance
- Ambient- and Elevated-Temperature Strength
- Coefficient of Thermal Expansion
- Fracture Toughness
- Elevated-Temperature Stability.
- Uniformity in Microstructure and Density
- Project Economical
- Availability of Materials.



L. Tools affect afore and after joining operation.

Tool wear change tool shape and size, and possibility of defect welding may occur and decline weld quality, wear mechanism calculated on interaction of tool and workpiece. Basically adhesive due to low tool rotation and abrasive wear due to high tool rotation. Tool wear is common, tool wear decline boost tool life. Feed ratio and transverse speed adjustment can be made for proper weld quality and tool wear protection. Aluminum and Magnesium alloys work piece material have steel tool which gain little wear, although steel tool not fit for Ti, Ni, Steel etc. welding and for these high strength material tools are manufactured from carbides, metal matrix composite with very high thermal resistance like WC–Co, TiC and PCBN has higher than 1000Uc.

M. Tool cost

FSW of aluminum alloy is significantly have low energy consuming cost, and process is economical where for hard material cost of energy and tool consumption is higher. Tool of pcBN tool used welding hard material. pcBN has high heat and pressure bearing capacity thus expensive tool. pcBN tool. Cost of pcBN tool is greater than typical tool life. Equipment and utility cost of FSW is respectively higher than cost of RSW. Tool of materials Si3N4, TiB2 have higher cost w.r.t pcBN tool. W–Re or W–La alloys less expensive than pcBN tool with super abrasive nature.

VI. CONCLUSION

Tool shape size depth design is responsible for amount of frictional heat generation, weld quality, downward force on tools. Aluminum and soft alloy tool is economical and long life tool. Tool material may react with oxygen from atmosphere with work pieces, pcBN and W alloys are essential have high durability, high adherence, high temperature stability, smaller wear w.r.t other tools materials where low fracture and high cost of pcBN is demerits and need improvement. W based alloys are economical and not hard and wear resistance used to weld steel and Ti alloys in defined range. Si3N4 is economical w.r.t pcBN for weld operation hence proposed material. Commercial applications for high strength material development increase the region of industrial benefits and fast production, reduce wear and corrosion add advantages over other process.

Material selection of tool decide the cost and project cost of operation and other properties like fatigue strength, fracture toughness, material hardness, thermal conductivity and expansion coefficient, weld quality, tool performance and wear. Pin cross sectional surface features such as threads enhance frictional heat generation, higher material flow rate and axial force developed. Forces on tool like axial, lateral and longitudinal is operation calculated as function of process parameter.

Detailed research in field of tool material improvement gives a wide scope to decline issue of fatigue, fracture strength, tools wear, reduce cost of welding and enhance high weld strength,

high weld quality, high durability, economical, easy alignment w.r.t work piece, machine and welder friendly, right material selection and good tool life for high commercial application for hard work piece material like Ti, Ni, Steel etc.

Research on tool design and material selection for engineering and cost benefits give a wide scope for development and application benefits. [17]

ACKNOWLEDGEMENT

I am grateful to the support of Department of Mechanical Engineering, SITE SVSU, a lot of thanks to my guide Mr. Guru S (Asst. Professor SITE, Meerut) and Prof. Dr. Ravish Srivastav (H.O.D – Mechanical, Meerut), my brother Dr. Asif Eqbal (Research Scholar, California University, U.S.A) and my parents who guide and support me their best and encourage me to carry out the research review on Friction Stir Welding.

V. REFERANCE

- [1] Azam Iqbal, Er. Guru Sewak Kesharwani, Prof. Dr. Ravish Kumar Srivastava, 02 | Feb 2020, An Extensive Review Study on Friction Stir Welding and Specifications. Volume: 07 Issue *Department of Mechanical Engineering, S.I.T.E, Swami Vivekanand Subharti University Meerut.* India.
- [2] Al-moussawi, Montadhar, 2018, A mathematical and experimental analysis of friction stir welding of steel. Available from Sheffield Hallam University Research Archive (SHURA)
- [3] Hanwen Zhao, 2Zhang Liqiang, December 2017, *Hanwen Friction Stir welding Technology, Volume 5 Issue 12 PP. 23-27, College of Mechanical Engineering, Shanghai University of Engineer Science, 201620, China Corresponding*
- [4] Santosh N. Bodake *Ashokrao Mane*, Number 1 (2017), Review paper on optimization of friction stir welding process parameters, Volume 10, Prof. (Dr.) A. J. Gujar *Professor, Department of Mechanical Engineering D. Y. Patil College of Engineering and Technology, Kolhapur.*
- [5] Sivakumar, Vignesh Bose , Raguraman D , Muruganandam D, Review Paper on Friction Stir Welding of various Aluminium Alloys. Dhanish Ahmed College of Engineering, Sri Sairam Engineering College.
- [6] Mihaela Iordachescu, Elena Scutelnicu, Danut Iordachescu, 2005, Microstructural Changes in Aluminium Alloys by Friction Stir Processing, Dunarea de Jos University of Galati, Romania.
- [7] Mohammed Yunus¹ and Mohammad S. Alsofi¹ 03 Apr 2018, Mathematical Modelling of a Friction Stir Welding Process to Predict the Joint Strength of Two Dissimilar Aluminium Alloys Using Experimental Data and Genetic Programming.
- [8] Salekrostam R., Besharati Givi M. K, Mechanical Properties of Stainless Steel 316 L via Friction Stir



- Processing, University of Tehran, Tehran, Vols. 297-301, pp 215-220, Iran Mechanical Engineering, University of Tehran. Enhanced.
- [9] Zhang Y. N, Cao X. *, Larose S and Wanjara P Review of tools for friction stir welding and processing
- [10] Mohsin Abdullah Al-Shammari, 2018, Effect of Friction Stir Welding and Friction Stir Processing Parameters on the Efficiency of Joints, Vol.21 No.2, pp.230-237, Nahrain Journal for Engineering Sciences (NJES).
- [11] Vivek Patel 1, Wenya* Li, Guoqing Wang 3, Feifan Wang 3, Achilles Vairis 1,4 and Pengliang Niu 1, 26 February 2019, Friction Stir Welding of Dissimilar Aluminum Alloy Combinations: State-of-the-Art.
- [12] Bakavos D and Prangnell P. B, 2009, 'Effect of reduced or zero pin length and anvil insulation on friction stir spot welding thin gauge 6111 automotive sheet', Sci. Technol. Weld. Join.14, 443–456.
- [13] Bakavos. D, Chen Y. C, Babout. L. and Prangnell P. B, 2011, 'Material interactions in a novel pinless tool approach to friction stir spot welding thin aluminum sheet', Metall. Mater. Trans. A, 42A, 1266–1282.
- [14] Ding. R. J and Oelgoetz. P. A, 1999 'Auto-adjustable probe tool for friction stir welding', US Patent no. 5893507.
- [15] Ding. R. J, , June 2000 'Force characterization on the welding pin of a friction stir welding retractable pin-tool using aluminum lithium 2195', Proc. 2nd Int. Conf. on 'Friction stir welding', Gothenburg, Sweden, TWI.
- [16] Thomas. W. M, Nicholas. E. D and Smith. S. D, 2001 'Friction stir welding-tool developments', Proc. Aluminum Automotive and Joining Sessions, 213–224, Warren dale, PA, TMS.
- [17] Skinner. M and Edwards. R. L, 2003 'Improvements to the FSW process using the self-reacting technology', Mater. Sci. Forum, 426, 2849–2854.
- [18] Sylva. G., Edwards. R and Sassa. T, September 2004, 'A feasibility study for self-reacting pin tool welding of thin section aluminum', Proc. 5th Int. Conf. on 'Friction stir welding', Metz, France, TWI.
- [19] Marie. F., Allehaux. D. and Esmiller. B, September 2004, 'Development of the bobbin tool technique on various Al alloys', Proc. 5th Int. Conf. on 'Friction stir welding', Metz, France, TWI.
- [20] Sorenson. C. D, Nelson. T. W, Packer. S. M and Steel, September 2004, 'Innovative technology applications in FSW of high softening temperature materials', Proc. 5th Int. Conf. on 'Friction stir welding', Metz, France, , TWI.
- [21] Reynolds. A. P and Lockwood. W. D, June 1999 'Digital image correlation for determination of weld and base metal constitutive behavior', Proc. 1st Int. Conf. on 'Friction stir welding', Thousand Oaks, CA, USA, , TWI.
- [22] Nelson. T. W, Hunsaker B. and Field. D. P, June 1999 Local texture Characterization of friction stir welds in 1100 aluminum', Proc. 1st Int. Conf. on 'Friction stir welding', Thousand Oaks, CA, USA, TWI.
- [23] Sutton. M. A, Reynolds. A. P, Yang. B. and Taylor. R, 2003, Mode I fracture and microstructure for 2024-T3 friction stir welds', Mater. Sci. Eng. A, A354, 6–16.
- [24] Lumsden. J, Pollock. G. and Mahoney. M, 2005 'Effect of tool design on stress corrosion resistance of FSW AA7050-T7451', in 'Friction stir welding and processing III', 19–25; San Francisco, CA, TMS.
- [25] Dubourg. L, Gagnon. F. O, St-Georges. L, Jahazi. M. and Hamel. F. G, October 2006 'Process window optimization for FSW of thin and thick sheet Al alloys using statistical methods', Proc. 6th Symp. on 'friction stir welding', Saint Sauveur, PQ, Canada, TWI.
- [26] Thomas. W. M, Nicholas. E. D, Needham. J. C, Temple-Smith P, Kallee. S. W. K. W. and Dawes. C. J, 1996 'Friction stir welding', UK Patent Application 2306366.
- [27] Colligan. K; 2005 'Tapered friction stir welding tool', US Patent no. 6669075, 2003.
- [28] Colligan. K. J and Pickens. J. R 'Friction stir welding of aluminum using a tapered shoulder tool', in 'Friction stir welding and processing III', 161–170, San Francisco, CA, TMS.
- [29] Nishihara. T and Nagasaka. Y, September 2004 'Development of micro-FSW', Proc. 5th Int. Conf. on 'Friction stir welding', Metz, France, TWI.
- [30] Dawes. C. J. and Thomas. W. M, June 1999, 'Development of improved tool designs for friction stir welding of aluminum', Proc. 1st Int. Conf. on 'Friction stir welding', Thousand Oaks, CA, USA, , TWI.
- [31] Brinckmann. S, Strombeck. A. Von, Schilling. C, dos Santos. J. F, Lohwasser. D. and Kocak. M, June 2000, 'Mechanical and toughness properties of robotic-FSW repair welds in 6061-T6 aluminum alloys', Proc. 2nd Int. Conf. on 'Friction stir welding', Gothenburg, Sweden, TWI.
- [32] Colligan. K. J, Xu. J and Pickens. J. R, 2003 'Welding tool and process parameter effects in friction stir welding of aluminum alloys', in 'Friction stir welding and processing II', Warrendale, PA TMS.
- [33] Packer. S, Nelson. T, Sorensen. C, Steel. R and Matsunaga. M, May 2003, 'Tool and equipment requirements for friction stir welding ferrous and other high melting temperature alloys', Proc. 4th Int. Conf. on 'Friction stir welding', Park City, UT, USA, , TWI.
- [34] Sorensen. C. D, Nelson. T. W and Packer. S. M, , September 2001 'Tool material testing for FSW of high-temperature alloys', Proc. 3rd Int. Conf. on 'Friction stir welding', Kobe, Japan, TWI.
- [35] Nelson. T. W, Zhang. H. and Haynes. T: 'Friction stir welding of aluminum MMC 6061-boron carbide.

IJEAST

INTERNATIONAL JOURNAL
OF ENGINEERING APPLIED SCIENCE
AND TECHNOLOGY

ABOUT IJEAST

International Journal of Engineering Applied Science and Technology (IJEAST) is a peer-reviewed, open access journal that publishes high-quality research papers in the field of Engineering, Applied Science and Technology.

IJEAST aims to provide a platform for researchers, academicians, and professionals to share their innovative ideas, research findings, and practical experiences with the global scientific community.

FOCUS AREAS

- Engineering
- Applied Science
- Technology
- Innovation & Development
- Interdisciplinary Studies



PEER REVIEWED

All submissions are rigorously peer reviewed to ensure quality.



OPEN ACCESS

Free and unrestricted access to research for all.



GLOBAL REACH

Connecting researchers and professionals worldwide.



TIMELY PUBLICATION

We ensure a swift and efficient publication process.



For more information, visit our website

www.ijeast.com



INTERNATIONAL JOURNAL
OF ENGINEERING APPLIED SCIENCE
AND TECHNOLOGY

✉ editor@ijeast.com

🌐 www.ijeast.com

📍 India



2455-2143