



IJEAST

INTERNATIONAL JOURNAL
OF ENGINEERING APPLIED SCIENCE
AND TECHNOLOGY



VOLUME : 1 ISSUE : 12 Print / Issue Publication Date: 30-Nov-2016



ISSN : 2455-2143



Indexed In



WWW.IJEAST.COM

editor@ijeast.com



AN OVERVIEW OF GRID INTERCONNECTION OF RENEWABLE SOURCES

Shilpi, Mukesh Kumar, Dr. Puneet Pahuja, Ashwani Kumar
Department of EE
Hindu College of Engg, Sonipat-131001

Abstract— Most of the amount of energy demand is supplied by the non-renewable sources, but these sources are producing air pollution problem & global warming, reducing fossil fuels and increasing rate have make it look towards the use as renewable energy sources .There is developing interest in renewable energy every side the world. Since most of the renewable sources are irregular in nature, it is a challenging task to combine renewable energy resources into the power grid. Grid connection ability of distributed generation attracts researchers due to the progressive demand for electricity and environment pollution concern as a new prominent technology for supplying reliable and clean power. RES are being increasingly connected in distribution systems employing Power Electronic Converters. Piercing DG such as Solar power generation, CHP with Electricity etc. is running under many subsidization schemes to let off global environmental issue and energy security issue. This paper presents an overview of grid interconnection with different types of renewable energy sources.

Keywords— Combined Heat and Power (CHP), Distributed Generation (DG), Renewable Energy Resources (RES)

I. INTRODUCTION

Renewable Energy Sources (RES) as a forthcoming potential energy solution against the problems occurs due to use of non-renewable sources. Basic Power Quality Requirements are current, voltage, frequency, etc. for interconnecting any equipment to the grid. Large-scale of renewable based systems present a wide range of technical challenges emerging mostly from the growing application of Power Electronic Devices at high power ratings. The combination of distributed energy sources needs transformations in micro grid and energy management systems that evidently gives control. The chosen of an energy resource for electricity generating to increasing concern about other characteristic such as publically, environmental and technological usually and effects of the power wellspring selection. For integration of smart grid and

renewable energy systems into a integrated system requires broad range of skills. These skills include new technology, procedures of interfacing, and general problem solving skills.

II. ROLE OF RENEWABLE ENERGY

In INDIA the use of renewable energy sources are developing with a slower pace but to overcome the problems occurs with the use of non-renewable energy resources. However, India lags behind the other nations in use of renewable energies. The renewable energy capacity (excluding large hydro) of India's total grid connected is around 26.96 GW out of this amount of energy 68.9% comes from wind renewable energy source while 4.59% comes from renewable energy source Solar PV cells. Renewable processing is advising as neat & clean sources of potency and optimal use of these resources reduce environmental concussion, generating minimum other wastes source and are feasible based on present and future economically and social needs.

III. GRID INTERCONNECTION WITH DFIG

The basic configuration of a DFIG wind turbine is shown as in Figure (1) The wind turbine and DFIG are connected through a mechanical shaft system, which consists of two shafts first is a low-speed turbine shaft and second is high-speed generator shaft and a gearbox. Wound-rotor induction generator is used in this configuration. This generator is connected at both the terminals i.e stator side and rotor side. The stator is directly jointed to the grid station while the rotor is fed with a variable frequency dc-link-voltage converter (VFC), which only needs handle a fraction (25-30%) of the total power to get the full control of the generator. The Variable Frequency Controllers has two converters which are power electronics based operated in four quadrants.

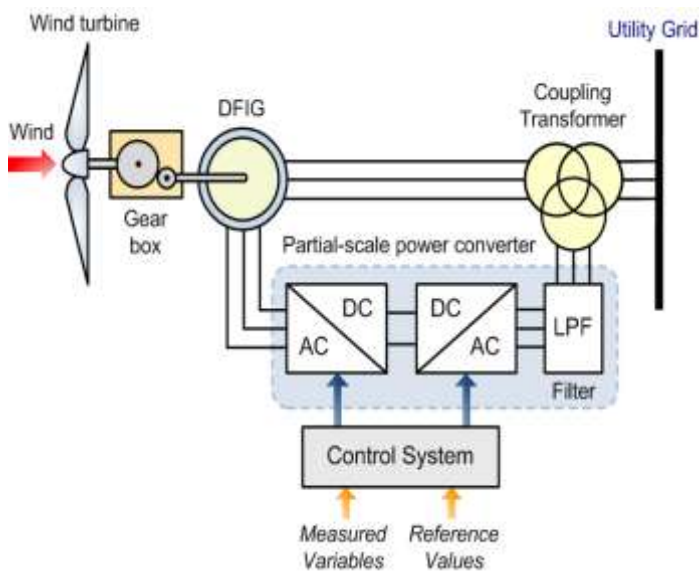

Fig. 1 Grid Interconnection with DFIG

IV. GRID INTERFACING INVERTER WITH WIND ENERGY SYSTEM

The system consists of grid interfacing inverter with the RES and having a set of three phase and single phase linear and nonlinear loads. The generated power is distributed by the grid interfacing voltage source inverter and the RES considered as a dc source. A filter is connected in parallel with the set of both types of loads, i.e., linear & non linear to find the harmonic current. The Filter which is used in this configuration is Active Power Filter. APF has power electronics based circuit which is voltage source inverter having four legs. The three legs are used to commit phase currents and one leg is specially designed to commit the neutral current. The four legs inverter has the advantage of less DC link capacitance and full utilization of DC link voltage. The inverter has power electronic switches and switching pulses are provided. The basic block diagram is as shown in figure 2

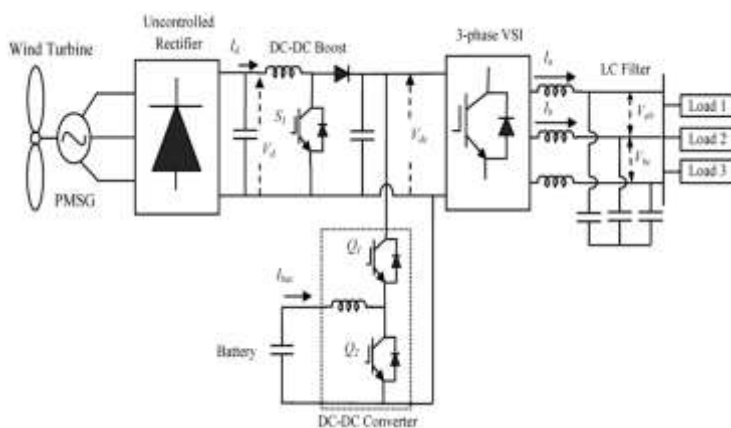

Fig. 2 Grid Interfacing Inverter with Wind Energy System

V. SOLAR PHOTOVOLTAIC SYSTEM

This technology is one of the most developed renewable energy (RE) technologies and there is an increasing demand of installation of solar photo voltaic in both the modes grid-connected as well as off-grid stand-alone modes. Although in recent years, the piercing of solar PV installation has increased significantly due to several initiatives. The main disadvantage of solar system is its cost of installation which is high for producing desired power level of electricity. The reason for this is the manufacturing cost of solar modules having low conversion efficiency. In this system the output of the Panels of Solar Cell depends on the intensity of solar energy and the clouds. Therefore the Power Quality problems not only depend on irradiation of PV Module but also are based on the maximum execution of solar photo-voltaic system involved PV modules, inverters, battery filters controlling mechanism etc. Special attention should be used to the voltage profile and the direction power flow which occurs way on the line. It has also offers that voltage and power quality problems can be solved by using the super-capacitors which result in an increment of about 22% in the cost of the PV system. The general block figure of grid connected PV system is shown in fig (3). Phases of system are depending on the grid station connection requirements. The system may be single phase or three phases.

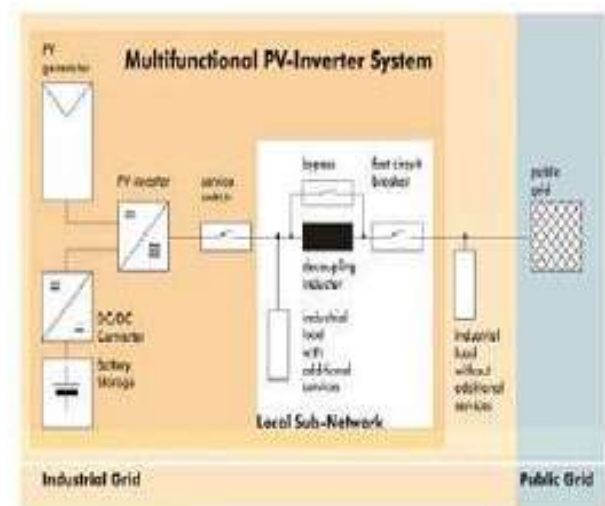

Fig 3: General structure of grid connected PV system

In general report, a grid line connected PV inverter is unable to control the reactive power and harmonic currents pinched from nonlinear loads. A multi-functional PV inverter for a grid line connected system shown in fig (4). The aim of this simulation was to compare three cases: no control, battery

Control and control of both the air conditioner and the battery by a cooperative demand control method. This system describes the system reliability which is improved through the functionality of UPS, harmonic compensation, reactive power compensation capability combined with the connection capability during the voltage sag condition of power system.

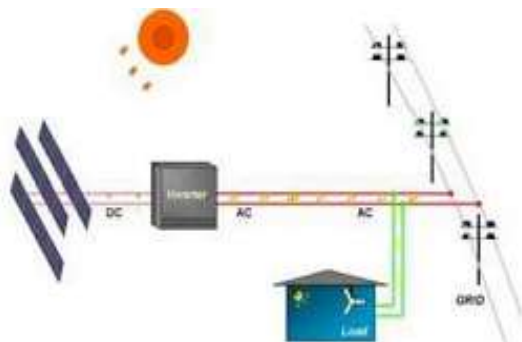

Fig. 4 Concept of Multifunctional PV-Inverter Systems

VI. MITIGATION OF POWER QUALITY PROBLEMS

There are two ways to mitigate the power quality problems—either from the customer side or from the availability side. The first approach is called load conditioning, which ensures that the equipment is less sensitive to power disturbances, allowing the operation even under important voltage dropped. The other solution is to install the line conditioning systems that repress the disturbances occurs in power system. Several devices including flywheels, super capacitors, other energy collection systems, constant voltage transformers, noise filters, isolation transformers, and transient voltage attack repressor is used for the mitigation of specific PQ problems. Facts devices are capable of solving PQ problems related with availability distribution and the end user equipments.

VII. ROLE OF FACTS DEVICES

A fact devices belong to power electronic items, which is considered to distribution systems to give solutions of a dispute occurs due to good power quality. STATCOM is one of the FACTS Devices. It means Static Synchronous Compensator. The STATCOM (or SSC) is a device which is connected in parallel to compensate reactive that is capable of generating and/or captivating reactive power [12] and output can be changed to control the specific parameters of an electric energy system. It is a strong state rule switching converter having capable of generating or absorbing independently controllable both power real and reactive power at its output terminals when it is badly from an energy source or any storage device of energy at its input terminals. Especially, the STATCOM considered in this chapter is a voltage-source converter that, from a given input of dc

voltage, produces a set of 3-phase ac-output voltages, each in phase with and coupled to the corresponding ac system voltage through a relatively small reactance (which is provided by either a device interface reactor or the leakage inductance of a connecting transformer). The energy-storage capacitor provides the dc voltage.

A STATCOM can improve power-system performance in such areas like:

1. The dynamic voltage control in distribution and transmission systems.
2. The damping of power-oscillation in power transmission systems.
3. The system's transient stability.
4. The control of voltage drop; and
5. The regulate of reactive power and also if needed active power in the connected line, requiring a dc energy source

VIII. MODEL OF HYBRID WIND/PV SYSTEM CONNECTED WITH GRID

Generally a hybrid energy system consists of two or more than two renewable energy sources used together to achieve a greater balance in energy supply and increased system efficiency.

In this paper, the hybrid energy system is a photovoltaic array coupled with a wind turbine. Figure 6 shows the schematic diagram of the proposed model. The configuration of hybrid wind and PV system is shown in Figure 8. This configuration is suitable for stand-alone hybrid power system used in remote areas. Wind energy source and solar energy which changes into electricity and then electricity is sent to loads for further use or stored in battery bank (future use).The topology of hybrid energy system consisting of different type speed WT coupled to a permanent magnet generator (PMG) and PV array. Both renewable energy sources are connected in parallel with each other to a common bus line (dc) through their separate dc-dc converters. The load may be dc which is connected to the dc bus line or may consist a PWM voltage source inverter which is used to convert the dc power into ac having frequency 50 or 60 Hz. The output of the hybrid generating system goes to the inverter, which converts the dc into ac. A battery charger is a device which is used to maintain the battery fully charged at a constant voltage which is known as dc bus line voltage. When the output of the system is not available, the dc load gets power from the battery or released to the inverter circuit to power ac loads, through a discharge diode. A battery discharge diode is used for the prevention of battery from being charged when the charger is opened after a full charge.

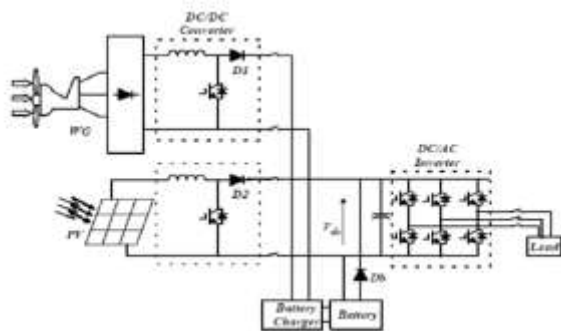

Fig. 5 Model of Hybrid Wind/PV System Connected With Grid

IX. CONCLUSION

This paper we review the grid interconnection with different types of renewable sources. And role of Facts devices in improving power quality in a grid connected renewable energy system. In all these techniques, Hybrid systems are the Good solution for a clean energy manufacturing and combination of both solar and wind power sources provide a realistic form of power generation. In this proposed system, Grid interfacing Solar/Wind turbine hybrid system can be used to supply continuous power to the loads.

X. REFERENCE

- [1] H Fujita, H Akagi, "The Unified Power Quality Conditioner", IEEE Trans on Power Electronics, vol.13, pp.315-322,.
- [2] P. Jintakosonwit, H. Fujita, H. Akagi, and S. Ogasawara, "Implementation and performance of cooperative control of shunt active filters for harmonic damping throughout a power distribution system," IEEE Trans. Ind. Appl., vol. 39, no. 2, pp. 556–564, Mar./Apr. 2003.
- [3] J. M. Guerrero, L. G. de Vicuna, J. Matas, M. Castilla, and J. Miret, "A wireless controller to enhance dynamic performance of parallel inverters in distributed generation systems," IEEE Trans. Power Electron., vol. 19, no. 5, pp. 1205–1213, Sep. 2004.
- [4] J. H. R. Enslin and P. J. M. Heskes, "Harmonic interaction between a large number of distributed power inverters and the distribution network," IEEE Trans. Power Electron., vol. 19, no. 6, pp. 1586-1593, Nov. 2004.
- [5] J. M. Carrasco, L. G. Franquelo, J. T. Bialasiewicz, E. Galván, R. C. P. Guisado, M. Á. M. Prats, J. I. León, and N.M. Alfonso, "Power electronic systems for the grid integration of renewable energy sources: A survey," IEEE Trans. Ind. Electron., vol. 53, no. 4, pp. 1002–1016, Aug. 2006.
- [6] Mde Alegria, J Andreu, J L Martin, P Ibanez, "Connection requirements for Wind farms: A survey on technical requirements and regulations" Renewable and Sustainable Energy Reviews, 2007, vol. 11, 1858-1872
- [7] B. Renders, K. De Gussem, W. R. Ryckaert, K. Stockman, L. Van- develde, and M. H. J. Bollen, (2008) "Distributed generation for mitigating voltage dips in low-voltage distribution grids," IEEE Trans. Power. Del., vol. 23, no. 3, pp. 1581–1588.
- [8] S.M. Muyeen, R Takahashi, T Murata, J Tamura "Application of STATCOM/BESS for Wind power smoothing and hydrogen generation" Electric power systems Reserch, 2009, vol 79, pp365-373.
- [9] S M Dehghan, M Mohammadian and A Y Varjani, "A New variable speed Wind energy Conversion System using Permanent Magnet Synchronous Regenerator and Z source Inverter", IEEE Trans Energy conv, 2009, vol 24, 714-724.
- [10] Nibitha N S, Soumya A V "The Analysis Of Grid Interconnected System At Distribution Level Using Renewable Energy Resources" International Journal Of Technology Enhancements And Emerging Engineering Research, Vol 3, Issue 10 Issn 2347-4289.
- [11] Rajveer Mittal, K.S.Sandhu and D.K.Jain, "An Overview of Some Important Issues Related to Wind Energy Conversion System (WECS)" International Journal of Environmental Science and Development, Vol. 1, No. 4, October 2010 ISSN: 2010-0264
- [12] Mukhtiar Singh, Vinod Khadkikar, Ambrish Chandra, Rajiv K. Varma, IEEE, (2011) "Grid Interconnection of Renewable Energy Sources at the Distribution Level with Power-Quality Improvement Features" VOL. 26, NO. 1.
- [13] Rajiv K. Varma, Ambrish Chandra, Vinod Khadkikar and Mukhtiar Singh, "Grid interconnection of Renewable Energy Sources at the Distribution level with Power-Quality improvement Features," IEEE Trans., Power Delivery, vol. 26, No.1, January 2011
- [14] Dr. S.M. Ali, B.K.Prusty, M.K.Dash, "Role Of Facts Devices In Improving Power Quality In A Grid Connected Renewable Energy System "Journal Of Engineering Research And Studies, Jers/Vol. Iii/ Issue Iii/July-Sept, 2012/33-35,E-Issn0976-7916



[15] S. Josephin Mary, J.Chelladurai, Sharon. D. Ronald ,”Power Quality Improvement In Grid Interconnection of Renewable Energy Sources Using Four Leg Inverter” International Journal Of Scientific & Engineering Research, Volume 4, Issue 5, May 2013 ,ISSN 2229-5518

[16] A.Rajashekar reddy, S.Swathi, P. sadanandam , Md.Yasin,” Grid Interconnection of Renewable Energy Sources with PowerQuality Improvement Features at the Distribution Level” International Journal of Engineering Research and Applications (IJERA) ISSN: 2248-9622 www.ijera.com Vol. 3, Issue 3, May-Jun 2013, pp.741-745

[17] Meena Agrawal, Arvind Mittal “Renewable Energy Integration & Topological Overview of Micro Grids” Journal of Basic and Applied Engineering Research Print ISSN: 2350-0077; Online ISSN: 2350-0255; Volume 1, Number 9; October, 2014 pp. 51-54

[18] T. Thillainayaki , P. Shanthi Grid Interconnection of Renewable Energy Sources at the Distribution Level with Power Quality Improvement Features International Journal of Advanced Research in Electrical, Electronics and Instrumentation Engineering Vol. 3, Special Issue 2, April 2014 ISSN (Print) : 2320 – 3765 ISSN (Online): 2278 – 8875

IJEAST

INTERNATIONAL JOURNAL
OF ENGINEERING APPLIED SCIENCE
AND TECHNOLOGY

ABOUT IJEAST

International Journal of Engineering Applied Science and Technology (IJEAST) is a peer-reviewed, open access journal that publishes high-quality research papers in the field of Engineering, Applied Science and Technology.

IJEAST aims to provide a platform for researchers, academicians, and professionals to share their innovative ideas, research findings, and practical experiences with the global scientific community.

FOCUS AREAS

- Engineering
- Applied Science
- Technology
- Innovation & Development
- Interdisciplinary Studies



PEER REVIEWED

All submissions are rigorously peer reviewed to ensure quality.



OPEN ACCESS

Free and unrestricted access to research for all.



GLOBAL REACH

Connecting researchers and professionals worldwide.



TIMELY PUBLICATION

We ensure a swift and efficient publication process.



For more information, visit our website

www.ijeast.com



INTERNATIONAL JOURNAL
OF ENGINEERING APPLIED SCIENCE
AND TECHNOLOGY

✉ editor@ijeast.com

🌐 www.ijeast.com

📍 India



2455-2143