



# IJEAST

INTERNATIONAL JOURNAL  
OF ENGINEERING APPLIED SCIENCE  
AND TECHNOLOGY



**VOLUME : 7    ISSUE : 08    Print / Issue Publication Date: 10-Feb-2023**



**ISSN : 2455-2143**



**DOI : 10.33564/IJEAST.2022.v07i08.006**

Indexed In



[WWW.IJEAST.COM](http://WWW.IJEAST.COM)

[editor@ijeast.com](mailto:editor@ijeast.com)

# A REVIEW STUDY IN TROUBLESHOOTING OF HYDRAULIC SYSTEMS IN CEMENT INDUSTRIES

Dr. Osama Mohammed Elmardi Suleiman  
Department of Mechanical Engineering  
Nile Valley University, Atbara, River Nile, Sudan

Mansour Hamad Elmamoun  
Mechanical Engineer  
Atbara Cement Factory, Atbara, Sudan

**Abstract:** Behind every hydraulic system there exists critical components that influence power transmission. To improve talent you should recognize how these components operate and affect the system i.e. learn the kinds of filter and piping used in hydraulic systems, describe the types and functions of hydraulic seals, and explain the operating principles of different types of pumps, and further learning the types and uses of accumulators, control valves, relief valves, cylinders, and even actuators.

In this research study appropriate problem-solving processes are applied, and this helps to comprehend the hydraulic concepts and hydraulic schematic representations. Therefore, it will enhance the knowledge and the capacity of troubleshooting the different hydraulics systems in the cement industry. This will enable the person to stay on top of the industry practices in hydraulics, explore the basics of a hydraulic system by reviewing the types and properties of hydraulic fluids, identifying the symbols used on hydraulic schematic representations, and explaining hydraulic circuit operations based on a schematic design.

**Keywords:** Hydraulic systems, cement industry, malfunction and maintenance, causes and remedy, suggested solutions

## I. INTRODUCTION

### 1.1 General Introduction

Cement is an easy and inexpensive industry. By this definition, Sudan is endowed with all the requirements of a successful cement industry. These are high-quality raw materials that meet the international specifications, which are all of them plentiful in many parts of the Sudan.

The cement raw materials available in Sudan had encouraged dam construction companies to launch their own cement plants near the required dam, simply to cut cement transportation cost. The most important component of cement

is high quality limestone, which is in abundance in different regions in the country of Sudan especially in River Nile and White Nile states. It is common knowledge that the constructors of the Sinnar (Mokwar) Dam in Central Sudan in the early 20th Century had set their own cement plant on the location. The availability of these materials was also of great help in the construction of the Meroe Dam in the early 2000s. The River Nile State in the Northern part of the country has now become the hub of cement industry in the country, hosting five big cement plants. Therein, we find Atbara Cement Factory, which was originally a government investment but was later on privatized. This factory was established in 1947 under the name Atbara Portland Cement, and it was found capable of competing with other international products of this commodity.

There are another five cement factories in this State; Alsalam (peace) Cement Plant, the Takamul (integration) Cement Plant, the Sakhr (rock) Alsudan cement Plant, Barber and the Ghubush Cement Plant. Figures 1 and 2 below shows Atbara Cement Factory and cement transport trucks.



Figure 1 Atbara Cement Factory



Figure 2 Cement Transport Trucks

Cement processing is similar in some ways to gold mining and extraction, with respect to limestone, blasting procedures, crushing or grinding operations, heating and cooling. Any technician or professional engineer who masters the stages of gold extraction can score limitless success in making cement and vice versa. Cement has become a strategic element in the construction business. It has caused an economic movement and has created many jobs. The production capacity of Atbara Cement Plant is 400,000 tons while the other five factories produce 2000-2750 tons per day.

Limestone available on the Western Bank of the River Nile is first broken with dynamite then elevated to the plants where it will be crushed through a milling process. At this stage, additional minerals are added to ensure the correct chemical composition for making and manufacturing of cement.

The kiln is at the heart of the manufacturing process. Once inside the kiln, the raw meal is heated to around 1,500 °C, a similar temperature to that of molten lava. At this temperature, chemical reactions take place to form cement clinker, which contains hydraulic calcium silicates. Then, the clinker is cooled and stored, ready for grinding, to produce cement. A small amount of gypsum (3 percent to 5 percent) is added to the clinker to regulate how the cement will set. The mixture is then very finely ground to obtain pure cement. During this phase, different mineral materials, called additions, may be added alongside the gypsum to give the cement specific properties, such as greater resistance to sulfates and aggressive environments. Finally, the cement is stored in silos before being shipped in bulk or in bags to the sites or the destination points where it will be used.

The Atbara Cement Plant sells its product to agents; each agent has a commercial number. Similar processes take place in the other cement plants. Another big cement factory is Rabak Factory in the White Nile State of central Sudan. The production capacity of the factory is 100,000 tons.

The Sudan cement has helped quite a lot in advancing the construction business. It has attracted many investors from the Gulf region and other parts of the World [1] – [56].

## 1.2 Hydraulics

Hydraulics are used for the generation, control, and transmission of power by the use of pressurized liquids.

Hydraulic topics range through some part of science and most of engineering modules, and cover concepts such as pipe flow, dam design, fluidics and fluid control circuitry, pumps, turbines, hydropower, computational fluid dynamics, flow measurement, river channel behavior and erosion.

In the hydraulic technology, we transmit and control forces and velocities by transmitting and controlling pressure and flow [57] – [64].

## 1.3 Classification of Hydraulics

Any device operated by a hydraulic fluid may be called a hydraulic device, but a distinction has to be made between the devices, which utilize the impact or momentum of a moving fluid, and those operated by a thrust on a confined fluid by pressure. This leads us to the subsequent categorization of the field of hydraulics into Hydrodynamics and Hydrostatics.

Hydrodynamics deals with the characteristics of a liquid in motion, especially when the liquid affects an object and releases a part of its energy to do some useful work. Hydrostatics deals with the potential energy available when a liquid is confined and Pressurized. This potential energy also known as hydrostatic energy is applied in most of the hydraulic systems. Pascal's law governs this field of hydraulics. It can thus be concluded that pressure energy is converted into mechanical motion in a hydrostatic device whereas kinetic energy is converted into mechanical energy in a hydrodynamic device.

## 1.4 Hydraulic fluids

Hydraulic fluid is a medium to transfer power in the system or the machinery. Hydraulic fluids play a very important role in the developing world.

The fluids are classified based on their viscosity, which makes a chart, which is useful for the industries to select the fluid for the particular function. The classifications ranges from a simple ISO (International Organization for Standardization) to the recent classification ASTM D 6080-97 which stands for American Society for Testing and Materials (classification based on viscosity).

### 1.4.1 Advantages of Fluid Power Systems

The main Advantages of Fluid Power Systems are described briefly as follows: 1. Not hindered by geometry of machine; 2. Provides remote control; 3. Complex mechanical linkages are eliminated;

4. Instantly reversible motion; 5. Automatic protection against overloads; 6. Infinitely variable speed control.

### 1.4.2 Classification of Hydraulic Fluids based on ISO Viscosity Grade

Most of the fluids used are classified with ISO standards. The ISO standard fluids are mainly classified based on the kinematic viscosity at 400°C. The fluid is mainly taken at 400°C which is taken as a reference temperature between the maximum operating and the ambient temperatures. The ISO



classification is done on 18 main fluids based on their viscosity grade. Table 1 below shows clearly the classification of hydraulic fluids based on ISO viscosity grade.

Table 1 Classification of Hydraulic Fluids based on ISO Viscosity Grade

<b>ISO Viscosity Grades based on Kinematic Viscosity [Centistokes/CST] at 400C</b>		
ISO VG	Minimum [CST]	Maximum [CST]
2	1.98	2.42
3	2.88	3.52
5	4.41	5.06
7	6.12	7.48
10	9	11
15	13.5	16.5
22	19.8	22.2
32	28.8	32.8
46	41.4	50.6
68	61.2	74.8
100	90	110
150	135	165
220	198	242
320	288	353
460	414	506
680	612	748
1000	900	1100
1500	1350	1650

### 1.4.3 Types of Hydraulic Fluids

There have been many liquids tested for use in hydraulic systems. Currently, liquids being used include mineral oil, water, phosphate ester, water-based ethylene glycol compounds, and silicone fluids.

The three most common types of hydraulic liquids are petroleum-based, synthetic fire-resistant, and water-based fire-resistant.

#### 1.4.3.1 Petroleum-Based Fluids

The most common hydraulic fluids used in shipboard systems are the petroleum-based oils. These fluids contain additives to protect the fluid from oxidation (i.e. antioxidant), to protect system metals from corrosion (i.e. anticorrosion), to reduce tendency of the fluid to foam (i.e. foam suppressant), and to improve viscosity.

Petroleum-based fluids are used in surface ships' electro hydraulic steering and deck machinery systems, submarines' hydraulic systems, and aircraft automatic pilots, shock absorbers, brakes, control mechanisms, and other hydraulic systems using seal materials compatible with petroleum-based fluids.

#### 1.4.3.2 Synthetic Fire -Resistant Fluids

Petroleum-based oils contain most of the desired properties of a hydraulic liquid. However, they are flammable under normal conditions and can become explosive when subjected to high pressures and a source of flame or high temperatures. Nonflammable synthetic liquids have been developed for use in hydraulic systems where fire hazards exist.

#### 1.4.3.3 Environmental Acceptable Hydraulic Fluids (EAHF)

These fluids are used in the application where there is a risk of leakage or spills into the environment, which may cause some damage to the environment.

These fluids are not harmful to the aquatic creatures and they are biodegradable. These fluids are used in forestry, lawn equipment, offshore drilling, dams and maritime industries. The ISO have classified these fluids as HETG (based on natural vegetable oils), HEES (based on synthetic esters), HEPG (polyglycols fluids) and HEPR (polyalphaolef in types).

### 1.4.4 Selection of Hydraulic Fluid for the System

#### 1.4.4.1 Effect of Viscosity on System Performance

The performance of pumps and motors are the important parameters for the overall efficiency of the system. There are two types of hydraulic efficiencies. One is mechanical efficiency and other is volumetric efficiency of the system. Mechanical efficiency relates to frictional losses in systems and volumetric efficiency relates to flow losses in the systems. Both of these depend on the viscosity of the fluid. As shown in the below figure viscosity of fluid is directly proportional to volumetric efficiency and inversely proportional to mechanical efficiency of the system. So fluid should be selected satisfying both these efficiencies for the maximum overall efficiency of the system.

Figure 3 below show diagrammatically mechanical, volumetric and overall efficiencies against viscosity plot.

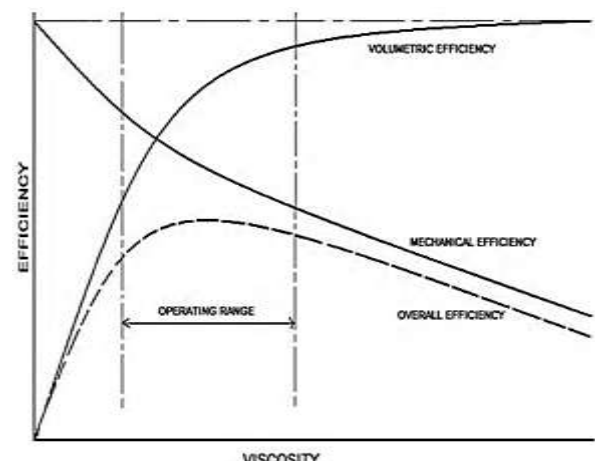

Figure 3 Efficiency versus Viscosity Plot

#### 1.4.4.2 Viscosity Selection Criteria:

The most common method for selecting hydraulic fluid is Temperature Operating Window or TOW method. Based on experimental results the majority of the pumps and motors provide satisfactory performance with a minimum of 13 CST under operating conditions and maximum of 860 CST during start-up of the system.

The below figure (Figure 4) is based on calculated temperature for the mid-range ISO VG (between 13CST to 860 CST) at 100 VI.

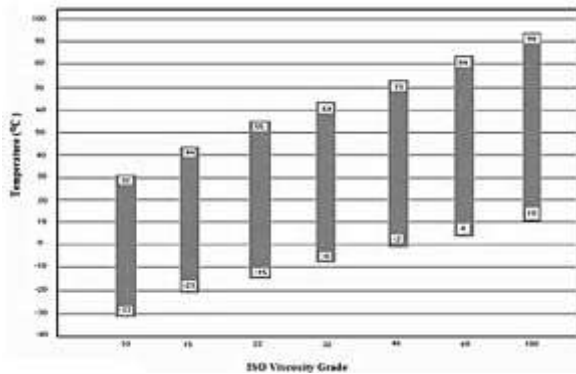

Figure 4 Calculated Temperature for the Mid-Range ISO VG

While selecting hydraulic fluid by this method, determine the lowest ambient temperature and the highest operating temperature of the system. Then select the fluid that falls in this range of temperature. For example if a hydrostatic transmission is considered, assume that the starting temperature is 0°C and the maximum operating temperature is 50°C. For this range of temperature, the suitable ISO VG is 32 VG and 46 VG. Thus, any of these viscosity grades can be selected for the hydrostatic transmission. What if the temperature does not fall in the above figure i.e. TOW method? There is an alternative temperature operating window (ALTOW) method. In this method ASTM D 341 viscosity-temperature chart is used for selecting the viscosity of fluid where it is not explained in this thesis work.

## II. HYDRAULIC SYSTEM COMPONENTS

### 2.1 Introduction

Regardless of its function and design, every hydraulic system has a minimum number of basic components in addition to a means through which the fluid is transmitted. A basic system consists of a pump, reservoir, directional valve, check valve, pressure relieve valve, selector valve, actuator, and filter. Figure 5 below shows diagrammatically the basic components of hydraulic systems [65] and [66].

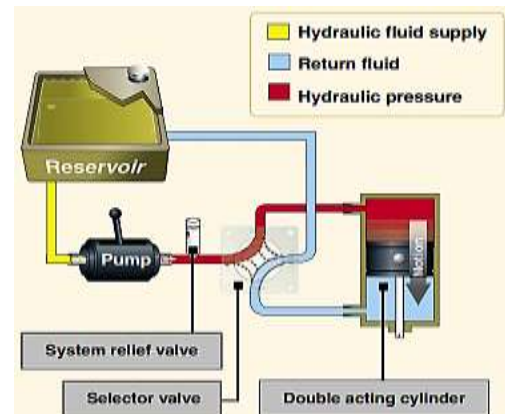

Figure 5 Basic Components of Hydraulic Systems

### 2.2 Hydraulic Pumps

The sole purpose of a pump in a hydraulic system is to provide flow. A pump, which is the heart of a hydraulic system, converts mechanical energy, which is primarily rotational power from an electric motor or engine, into hydraulic energy.

#### 2.2.1 Pump Classification

Pumps can be broadly listed under two categories:

1. Non-positive displacement pumps and
2. Positive displacement pumps.

##### 2.2.1.1 Non-Positive Displacement Pumps

They are also known as hydro-dynamic or roto - dynamic pumps. In these pumps the pressure produced, is proportional to the rotor speed. In other words, the fluid is displaced and transferred using the inertia of the fluid in motion. These pumps are incapable of withstanding high pressures and are generally used for low-pressure and high-volume flow applications.

Examples of these pumps are the centrifugal and axial (propeller) pumps. Normally their maximum pressure capacity is limited to 20–30 kgf/cm<sup>2</sup>. They are primarily used for transporting fluids from one location to the other and find little use in the hydraulic or fluid power industry.

##### 2.2.1.2 Positive Displacement or Hydrostatic Pumps

As the name implies, these pumps discharge a fixed quantity of oil per revolution of the pump shaft. In other words, they produce flow proportional to their displacement and rotor speed. A majority of the pumps used in fluid power applications belong to this category. These pumps are capable of overcoming the pressure that results from the mechanical loads on the system as well as the resistance to flow due to friction. Thus, the pump output flow is constant and not dependent on system pressure. Another advantage associated with these pumps is that the high-pressure and low-pressure areas are separated and hence, the fluid cannot leak back and return to the low-pressure source.

These features make the positive displacement pump most suited and universally accepted for hydraulic systems.

The advantages of positive displacement pumps over non-positive displacement pumps are: 1. Capability to generate high pressures; 2. High volumetric efficiency; 3. Small and compact with high power to weight ratio; 4. Relatively displays smaller changes in efficiency throughout the pressure range; 5. Wider operating range i.e. the capability to operate over a wide pressure and speed range.

## 2.2.2 Types of Hydraulic Pumps

### 2.2.2.1 Gear Pump

Gear pumps as the name suggests make use of the principle of two gears in mesh in order to generate pumping action. They are compact, relatively inexpensive and have few moving parts. Gear pumps are further classified as: External gear pumps; internal gear pumps; lobe pumps; and Gerotor pumps.

**1. External Gear Pump:** An external gear pump consists of two gears usually equal in size, which mesh externally and are housed in a pump case. Each gear is mounted on a shaft, which is supported by needle bearings in the case covers. One of these shafts is coupled to a prime mover and is called the drive shaft. The gear mounted on this shaft is called the drive gear. It drives the second gear as it rotates. Two side plates are provided one on each side of the gear. The side plates are held between the gear case and case covers. The suction side is where the teeth come out of the mesh. The volume expands in this region leading to a drop in pressure below the atmospheric value, which results in the fluid getting pushed into this void. The fluid is trapped between the housing and the rotating teeth of the gears. The discharge side is where the teeth go into the mesh and here the volume decreases. Since the pump has a positive internal seal against leakage, the fluid is forced into the outlet port. The number of gear teeth, the volume of fluid between each pair of teeth and the speed of rotation determine the amount of displacement in gear pumps. Figure 6 shows the internal parts of an external gear pump.

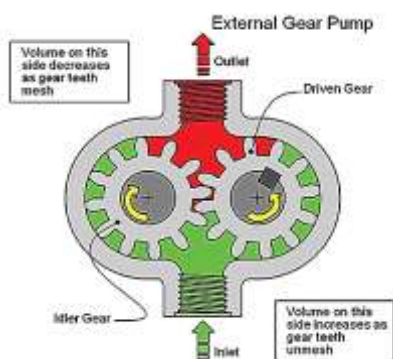

Figure 6 the Internal Parts of an External Gear Pump

**2. Internal Gear Pump:** Internal gear pump is another variation of the basic gear pump in its internal construction and operation. The design consists of an internal gear, a

regular spur gear, a crescent-shaped seal and an external housing. As power is applied to either gear, the motion of the gears draws the fluid from the suction, and forces it around both the sides of the crescent seal. This acts as a seal between the suction and discharge ports. When the teeth mesh on the side opposite to the crescent seal, the fluid is forced out through the discharge port of the pump. Similar to the external gear pump, internal gear pumps also have an in-built safety relief valve. Figure 7 shows the internal parts of an internal gear pump.

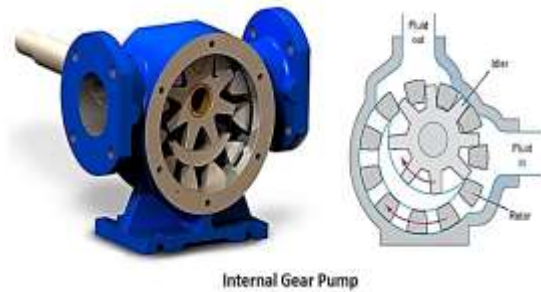

Figure 7 the Internal Parts of an Internal Gear Pump

**3. Lobe Pump:** The lobe pump is yet another variation of the basic gear pump. This pump operates in a fashion quite similar to that of an external gear pump, but unlike external gear pumps, the gears in these pumps are replaced with lobes, which usually consist of three teeth. Unlike the external gear pumps, both the lobes are driven externally so that they do not actually make contact with each other. They are quieter than the other gear pumps. Due to the smaller number of mating elements, the lobe pump will show a greater amount of pulsation. However, its volumetric displacement is generally greater than other types of gear pumps. Although these pumps have a low-pressure rating, they are well-suited for applications involving shear-sensitive fluids. Figure 8 shows the internal parts of a lobe pump.

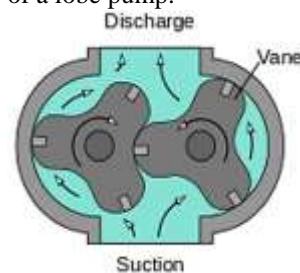

Figure 8 the Internal Parts of a Lobe Pump

**4. Gerotor Pump:** Gerotor pumps are one of the most common types of internal gear pumps whose operation is quite similar to that of an internal gear pump. The inner gear rotor (i.e. Gerotor element) is power driven and draws the outer gear rotor around as they mesh. This forms the inlet and outlet discharge pumping chambers between the rotor lobes. The tips of the inner and the outer lobes make contact to seal the

pumping chambers from each other. The inner gear has one tooth less than the outer gear, and the volumetric displacement is determined by the space formed by the extra tooth in the outer gear. Figure 9 shows the internal parts of a Gerotor pump.

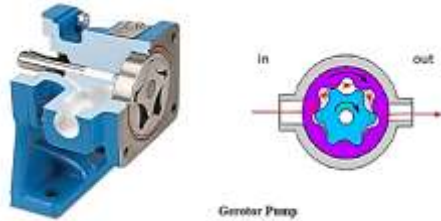

Figure 9 the Internal Parts of a Gerotor Pump

### 2.2.2.2 Vane Pump

The pumping mechanism of a vane pump essentially consists of a rotor, vanes, ring and a port plate with kidney-shaped inlet and outlet ports.

There are two types of vane pumps: Unbalanced vane pump and balanced vane pump.

**1. Advantages and Disadvantages of Balanced Vane Pumps:** The advantages of balanced vane pumps are as follows: 1. the balanced pump eliminates the bearing side loads and therefore, high operating pressure can be used; 2. the service life is high compared to unbalanced type due to less wear and tear.

**2. Disadvantages of Balanced Vane Pumps:** The disadvantages of balanced vane pumps are as follows: 1. They are fixed displacement pumps; 2. Design is more complicated; 3. Manufacturing cost is high compared to unbalanced type. Figure 10 below shows the internal parts of a vane pump.

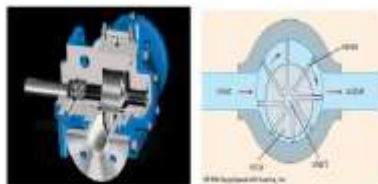

Figure 10 the Internal Parts of a Vane Pump

### 2.2.2.3 Piston Pump

Piston pumps are high-pressure, high-efficiency pumps. A piston pump works on the principle that a reciprocating piston can draw in fluid when it retracts in a cylinder bore and discharge it when it extends. In other words, these pumps convert the rotary motion of an input shaft to an axial reciprocating motion of the piston.

Piston pumps are of two types, which could be classified into the following types:

**1. Axial Piston Pumps:** Axial piston pumps have a circular piston group, which rotates against an angled swash plate. As the rotary group turns, the pistons are pushed forwards and

backwards. A grooved timing plate at the top of the pistons controls the fluid, which is drawn through the suction side of the pump, and out through the pressure side. Figure 11 below shows the internal parts of an axial piston pump.

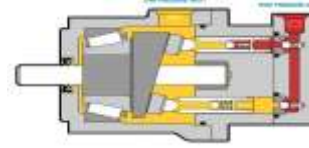

Figure 11 the Internal Parts of an Axial Piston Pump

**2. Radial Piston Pumps:** Radial piston pumps consist of reciprocating pistons and cylinders and can be classified as cam or rotating piston pumps. Figure 12 below shows the internal parts of a radial piston pump.



Figure 12 the Internal Parts of a Radial Piston Pump

## 2.3 Hydraulic Motors

Hydraulic motor converts hydraulic energy into mechanical energy i.e. a rotating shaft. It uses hydraulic pressure and flow to generate torque and rotation, you can use hydraulic motors for many applications, such as winches, crane drives, self-driven cranes, excavators, mixer etc.

The design of a hydraulic motor and a hydraulic pump are very similar. For this reason, some pumps with fixed displacement volumes may also be used as hydraulic motors.

### 2.3.1 Types of Hydraulic Motors

- 1. Hydraulic Gear Motors:** Includes Hydraulic Gear Motor and Gerotor Gear Motor.
- 2. Hydraulic Vane Motors:** Includes Balanced Vane Motor.
- 3. Hydraulic Piston Motors:** Includes Axial Piston Motor and Radial Piston Motor.
- 4. Part-turn Actuators:** Includes Rotary Actuator and Rack and Pinion Actuator.

## 2.4 Hydraulic Valves

A valve is a control device used for adjusting or manipulating the flow rate of a liquid or gas in a pipeline. The valve essentially consists of a flow passage whose flow area can be varied. There are three types of control valves:

### 2.4.1 Direction Control Valves

Direction control valves are used to control the direction of flow in a hydraulic circuit. It is that component of a hydraulic system that starts stops and changes the direction of the fluid flow.

### 2.4.2 Pressure Control Valves

Pressure control valves protect the system against overpressure conditions that may occur either because of a gradual build up due to decrease in fluid demand or a sudden surge due to opening or closing of the valves.

### 2.4.3 Flow Control Valves

Flow control valves control the fluid flow rate in a hydraulic system. Flow control valves regulate the volume of oil supplied to different parts of a hydraulic system.

## 2.5 Hydraulic Accessories

### 2.5.1 The Reservoir

The reservoir as the name suggests, is a tank, which provides uninterrupted supply of fluid to the system, by storing the required quantity of fluid.

### 2.5.2 Hydraulic Filters

Hydraulic filters remove dirt and particles from fluid in a hydraulic system. The performance for every hydraulic filter is measured by its contamination removal efficiency, i.e. high dirt-holding capacities. Almost every hydraulic system contains more than one hydraulic filter.

#### 2.5.2.1 Types of Hydraulic Filters

Hydraulic filters are often classified by where they are designed to be placed in a hydraulic system. The figures (Figures 13 – 18) below show the common filter types:

**1. In-line Filter:** The in-line filter is placed directly on the fluid line; may be suction side (before the pump) or pressure side (after the pump but before valves and cylinders); inlet, outlet, and media are aligned. Figure 13 below shows the in-line filter.



Figure 13 the In-line Filter

**2. Off-line Filter:** The off-line filter consists of a separate pump and a filter linked directly to the reservoir; often used to supplement main system filters. Figure 14 below shows the off-line filter.



Figure 14 the Off-line Filter

**3. Tank Filter:** Tank filter is suitable for low-pressure systems; machine tools, forest harvester equipment, and casting machines. Figure 15 below shows the tank filter.



Figure 15 the Tank Filter

**4. Spin-on Filter:** The spin-on filter consists of an in-line head screwed onto a threaded canister; easy to install and economical. It is used in systems without flow surges; low pressure systems. Figure 16 below shows the spin-on filter.



Figure 16 the Spin-on Filter

**5. Return Line:** Return line filter is placed directly on return line; it can also be spin-on, in-line, or tank-mounted. It is suitable for systems where pumps need the most protection; economic; casting machines, drilling rigs. Figure 17 below shows the return line filter.



Figure 17 the Return Line Filter

**6. Duplex Filter:** The duplex filter is actually a valve/filter assembly permitting flow to two separate filters in order to maintain flow during filter maintenance. It is used mainly in continuous flow systems; critical hydraulic systems. Figure 18 below shows the duplex filter.



Figure 18 the Duplex Filter

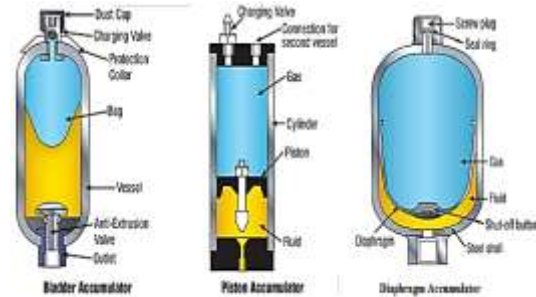

Figure 19 the Internal Components of the Three Types of Accumulators, Namely Bladder, Piston and Diaphragm Accumulators

### 2.5.3 Hydraulic Accumulators

Accumulators can take a specific amount of fluid under pressure and store it. The fluid is then released when it's required to perform a specific task in the hydraulic system. Accumulators can provide several functions, such as: Energy storage; Compensation of leakage oil; Compensation of temperature fluctuations; Emergency operation; and Dampening vibrations.

#### 2.5.3.1 Types of Hydraulic Accumulators

Accumulators comprise of two compartments: one of the compartments is filled with gas; the other compartment, which is connected to the hydraulic circuit, is filled with fluid. The accumulator shell is made of carbon steel, stainless steel or Aluminium. Depending on separating elements, it can be classified into three types of hydraulic accumulators: Bladder accumulators; Diaphragm accumulators; and Piston accumulators

**1. Bladder Accumulators:** The most popular of these is the bladder type. Bladder accumulators feature fast response (less than 25 milliseconds), a maximum gas compression ratio of around 4:1 and a maximum flow rate of 15 liters (4 gallons) per second, although "high-flow" versions up to 38 liters (10 gallons) per second are available. Bladder accumulators also have good dirt tolerance; they are mostly unaffected by particle contamination in the hydraulic fluid.

**2. Piston Accumulators:** Piston accumulators, on the other hand, can handle much higher gas compression ratios (up to 10:1) and flow rates as high as 215 liters (57 gallons) per second. Unlike bladder accumulators whose preferred mounting position is vertical to prevent the possibility of fluid getting trapped between the bladder and the shell, the piston accumulators can be mounted in any position.

**3. Diaphragm Accumulators:** Diaphragm accumulators have most of the advantages of bladder-type units but they can handle gas compression ratios up to 8:1. They are limited to smaller volumes, and their performance can sometimes be affected by gas permeation across the diaphragm. Figure 19 below shows the internal components of the three types of accumulators, namely bladder, piston and diaphragm accumulators.

### 2.5.4 Heat Exchangers

The steady-state temperature of the fluid depends on the rate of heat generation and the rate of heat dissipation. If the fluid-operating temperature is excessive, it means that the rate of heat dissipation is inadequate for the system. Assuming that the system is reasonably efficient, the solution is to increase the rate of heat dissipation. This accomplished by the use of 'coolers', which are commonly known as heat exchangers.

### 2.5.5 Fluid Conductors – Hydraulic Pipes and Hoses

Fluid conductors comprise that part of the hydraulic system that is used to carry fluid to the various components. These conductors include the likes of steel tubing, steel pipes and hydraulic hoses.

## III. MALFUNCTION AND MAINTENANCE OF HYDRAULIC SYSTEM

### 3.1 Malfunction and Maintenance of Hydraulic Pumps

The pump is probably the component most subject to wear in a hydraulic system and the one most likely to cause a sudden or gradual failure in the system. Pump trouble is usually characterized by increased noise, increased heat, and erratic operation of cylinders, difficulty to develop full output, decreased speed of cylinders or hydraulic motors, or failure of the system to work at all.

One of the following problems will most likely be the cause if any of the above symptoms appear, if they are indeed caused by the pump [67].

#### 3.1.1 Pump Cavitation

Cavitation is the inability of a pump to draw in a full charge of oil. When a pump starts to cavitate its noise level increases, and it may become extremely hot around the shaft and front bearing. Other symptoms of pump cavitation are erratic movement of cylinders, difficulty in building up full pressure, and a milky appearance of the oil.

If cavitation is suspected, check these points: 1- Check the condition of pump suction strainer. Clean it even if it does not look dirty; 2- Check for restricted or clogged pump inlet plumbing. If hoses are used, be sure they are not collapsed; 3-



Be sure that the air breather on top of the reservoir is not clogged with lint or dirt; 4- Oil viscosity could "be too high for the particular pump. Some pumps cannot pick up the prime on heavy oil or will run in a partially cavitating condition; 5- Check suction strainer size. Be sure that original strainer has not been replaced with one of smaller size; 6- The use of high quality oil may reduce formation of varnish and sludge; 7- Determine recommended speed of pump. Check pulley and gear ratios. Be sure the original electric motor has not been replaced with one, which runs at a higher speed; 8- Be sure that pump has not been replaced with one which delivers a higher flow which might overload the suction strainer. Increase suction strainer size if necessary.

### 3.1.2 Water Leaking Into the System

Water leaking into the system will cause the oil to have a milky appearance while the system is running, but the oil will usually clear up a short time after the system is shut down as water settles to the bottom of the reservoir. Water may enter into the system in these, possibly other ways:

- 1- A leak in a shell and tube heat exchanger may allow water to mix with oil.
- 2- Condensation on the inside walls of the reservoir.
- 3- Be sure that any tubing or piping which carries cooling water inside the air space of the reservoir enters and leaves below the oil level, so water cannot condense on it.

### 3.1.3 Oil Leakage around the Pump

**1. Leakage around the Shaft:** Leakage may only occur after the pump has been stopped. Prematurely worn shaft seals may be caused by excessive oil temperature. Otherwise, rubber seals considered have a very short life.

**2. Leakage around a Pump Port:** Check tightness of fittings in the ports. If dry seal pipe threads are used, there should be no need to use a pipe thread sealant. Beware of screwing taper pipe threads too tightly into a pump body casting. This may cause the casting to crack.

**3. Leakage caused by a Small Crack in the Body Casing:** If leakage is from a small crack in the body casing, this most likely has been caused either by screwing a pipe fitting in too tightly, or from operating the pump in a system where the relief valve is set too high.

### 3.1.4 Pump Delivering too little or no Flow

- 1. Shaft Turning in Wrong Direction:** Shut down immediately. Reversed leads on a 3 phase motor are the commonest cause for wrong rotation. Pumps must be run in the direction marked on their nameplate or case.
- 2. Intake Clogged:** Check suction filter for dirt, and check for collapsed intake hoses.
- 3. Low Oil Level in the Reservoir**
- 4. Stuck Vanes, Valves, or Pistons:** Stuck vanes, valves, or pistons, from varnish in the oil or from rust or corrosion.

Varnish indicates that the system is running too hot. Rust or corrosion may mean water is getting into the oil.

**5. Oil too thin:** Oil too thin, either from wrong choice of oil or from thinning out at high temperature.

**6. Pump running too slow**

**7. Cavitation of Pump Inlet**

**8. Air Leaking into the System from Low Oil or Other Cause**

**9. Mechanical Noise:** Mechanical noise caused by loose or worn coupling, loose set screws, badly worn internal parts, etc.

**10. System may be running too hot**

**11. Pump may be running too fast**

### 3.1.5 Short Pump Life

1. Operation of pump above catalog pressure rating, especially if pump must maintain this pressure for a high percentage of total running time; 2. Oil of wrong viscosity or of poor quality; 3. Operating the oil at excessively high temperatures; 4. Inadequate filtering; 5. Failure to keep suction strainer clean; 6. Misalignment of pump shaft with driving motor or engine. Note: When replacing a foot mounted pump, leave the bracket and replace only the pump and the new pump will not have to be realigned with the driving source; 7. Air or water may be leaking into the system; 8. Running the pump too fast or too slow; 9. Inlet cavitation from other causes.

### 3.2 Malfunction and Maintenance of Hydraulic Filters

In the following points mentioned below are the most malfunctions, which occur, in hydraulic system and how proper maintenance can be done for best performance:

#### 3.2.1 Low Outlet Pressure

1- Low inlet pressure, change system conditions to achieve higher pressure; 2- Filter is blocked due to dirt and non-cleaning for long periods of time, change in water quality, and dirt development in mainlines. Also, there may be Leaks or cracks in main pipes which need to be repaired.

#### 3.2.2 Leaks from Filter Parts

1- Damaged sealing. The leaking item should be disassembled and replaced; 2- Replace the part if necessary and make sure all bolts are tightened.

### 3.3 Malfunction and Maintenance of Hydraulic Cylinder and Actuators

#### 3.3.1 Damaged Piston Rods or Rod Bearing

Damaged piston rods or rod bearings are the most common cause of rod seal failure. The usual causes of such damage are poor alignment between the cylinder and its load, resulting in side loading; or a bent piston rod, resulting from the use of an undersized rod in a thrust application.

Figure 20 below shows the wear in gland and seal which results from excessive side loading. The brass paste on seal is a mixture of gland material and hydraulic fluid.



Figure 20 the Wear in Gland and Seal which results from Excessive Side Loading

### 3.3.2 Contaminated Fluid:

Contaminated fluid can also cause premature rod seal failure. Abrasive particles suspended in the fluid can damage the seal and the piston rod surface, while airborne contamination can be drawn into a cylinder via a faulty wiper seal. Water for example is a common contaminant in mineral oil systems.



Figure 21 the Contamination Damage in Rod Seal

Figure 21 above shows the contamination damage is apparent in this rod seal, where the serrations are worn completely away. The seal on the right is a new one, shown for comparison.

### 3.3.3 Extreme Temperatures:

Extreme temperature applications pose two challenges. First, the temperature itself may limit the choice of seal materials and geometries, e.g.: polyurethane seals should be restricted to a maximum of 50°C, in order to avoid hydrolysis of the seal compound. Second, the fluids used in such applications often have less lubricity than mineral oil-based fluids. Figure 22 below shows the cracked outer sealing lip of wiper seal which displays Damage caused by excessive heat.



Figure 22 The Cracked Outer Sealing Lip of Wiper Seal which displays Damage caused by Excessive Heat

### 3.3.4 Hydraulic Cylinder Not Moving

#### 1- Directional Valve Failure:

Check power to solenoids, determine if it is shifting, valves may need cleaning or repair, coil or solenoid armature may be burned out, check electrical wires and connections.

2- **Insufficient Pressure Supplied:** Check system pressure.

2- **Hydraulic Line Problem:** Check for kinked, dented or crushed hoses and tubes, check for damaged fittings.

4- **Defective Actuator:** Check cylinder condition - piston rod bent or cylinder barrel dented causing binding, barrel ID is scored or corroded causing excessive friction, seals worn causing oil bypassing piston.

3- **5- Load Exceeds Capacity of Actuator:**

Check system pressure and size of piston and calculate forces and compare to load, allow for friction, force vector geometry and pressure loss.

6- **Hydraulic Circuit Error:** Valve installed incorrectly, check valve backwards, lines installed incorrectly, breather port on single acting cylinder plugged

### 3.3.5 Routine Maintenance of Hydraulic Actuators

1-Check and adjust the compression relief valve operating pressure to ensure that the maximum actuator compression force is consistent with the current test requirements.

2- Clean exposed areas of the actuator piston rod with a clean, dry, lint free rag. If the actuator is continually exposed to a dirty operating environment, clean the piston rod on a daily basis.

3- Inspect actuator piston rod and seals for excessive wear and/or leakage. Small scratches in the axial direction of the piston rod or polishing of the rod surface is considered normal operating wear.

4- Change actuator seals if necessary. Actuator assemblies may require more or less frequent seal changes depending on usage. External oil leakage and/or decreased performance are indications of seal wear.

### 3.4 Accumulator Failure: The Most Common Causes and Solutions

1. Picked out pin hole near top of bladder. This happens due to the operation of the accumulator with little or no recharge which allows fluid pressure to force bladder to extrude into gas valve. So, always operate accumulator with proper nitrogen gas recharge; 2- Bubbles, flaking on bladder surface, or burnt smell. This is caused by the use of incompatible fluid, or excessive temperature. Refer to rubber compatibility chart and temperature chart for correct elastomeric compounds; 3- Grooves or Holes on bladder surface. This symptom is due to fluid contamination, which causes foreign debris entrapment between bladder and shell during cycling, to avoid this problem use clean fluid and proper filtration; 4- Broken or

damage gas valve or threads. This always happens due to excessive torque used to install gas valve or threads. In this case you don't have choice other than the replacement of damaged parts by new ones; 5- Gas valve is leaking gas. Dirt may get into the gas valve stem keeping the valve core from sealing, first using shop air or nitrogen, blow out the cleaned stem and recharge using dry nitrogen only. Then check for leakage using soapy water. If leakage continues replace the gas valve stem.

#### IV. HYDRAULIC SYSTEMS IN CEMENT PLANTS

##### 4.1 Cement Production Process

A cement production plant consists of the following three processes:

1. Raw material process; 2. Clinker burning process; 3. Finish grinding process.

Figure 23 below shows cement processing and production line. Raw material process starts from crusher area since impact crusher crushes the limestone so that the size of the stones that comes out from the crusher should be less than 20 mm in diameter, after that raw material stock is kept in large storage reservoirs.

Next, the raw meal will be ground by vertical mills and stored in two raw material homogenizing silos, which are equipped for this project. During the production period, if the plant intends to produce different types of cement, these two silos can store different types of raw meal, which is convenient for shifting. They can store one type raw meal as well.

The raw material mixture enters the kiln at the elevated end, and the combustion fuels are generally introduced into the lower end of the kiln in a countercurrent manner. The materials are continuously and slowly moved to the lower end by rotation of the kiln. As they move down the kiln, the raw materials are changed to cementitious or hydraulic minerals because of the increasing temperature inside the kiln. The fuels used in the kiln are coal and occasionally oil.

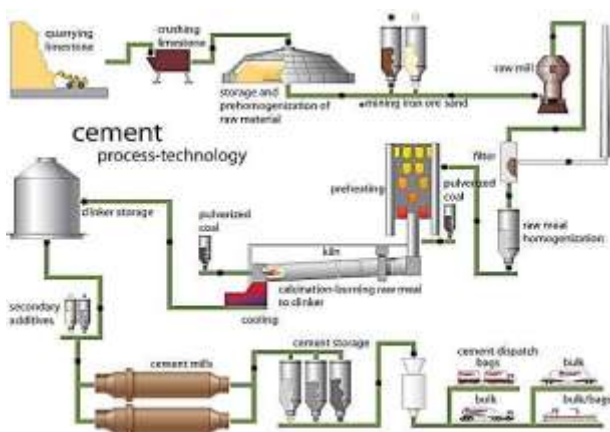

Figure 23 Cement Processing and Production line

The final step in cement manufacturing involves a sequence of blending and grinding operations that transforms clinker to

finished Portland cement. Up to 5 percent gypsum or natural anhydrite is added to the clinker during grinding to control the cement setting time, and other specialty chemicals are added as needed to impart specific product properties. Milling operation is accomplished almost exclusively in ball mills. Typically, the final product is carried in a closed-circuit system, in which the operation of product sizing is done by air separation.

The finished cement powder leaving the mill is sent into the homogenization silo through the elevator on the silo side and poured at the top of the silo, and is uniformly distributed by layers to form multilayer bed of material accumulated at different times, then the fine powder is filled in bags inside rotary packers, and the finally packed material is shipped by trucks to its destination points [68] – [72].

##### 4.2 Hydraulic System in Production Line (ACCL)

###### 4.2.1 Crushers Area

**1. Limestone Crusher:** The main components of limestone crusher as are as shown in the schematic diagram below (Figure 24): 1. Housing lower section, 2. Housing upper section, 3. Hinged section, 4. Front impact apron, 5. Rear impact apron, 6. Spindle, 7. Adjusting device, 8. Locking bolt, 9. Rotor, 10. Blow bar, 11. Pillow block, 12. Inspection door, 13. Hydraulic cylinder for rear hinged section, 14. Hydraulic cylinder for impact aprons, 15. Hydraulic cylinder for the grinding path.

The function of hydraulic unit in lime stone crusher is to open and close the main door of the crusher using large hydraulic cylinder also, to control and adjusting the gap between rotor and impact aprons otherwise there must be another hydraulic cylinders with extended rod used for moving, extracting and adjusting grinding path.

The hydraulic unit - assembled, checked, prepared and supplied by OEM must be stored so that it is protected against dirt, weather and mechanical influences.

Cleanliness of the unit is of paramount importance, all connections (pipes and tubes, etc.) are to be kept clean at all times, also the correct hydraulic fluid according to the standard types is to be available.

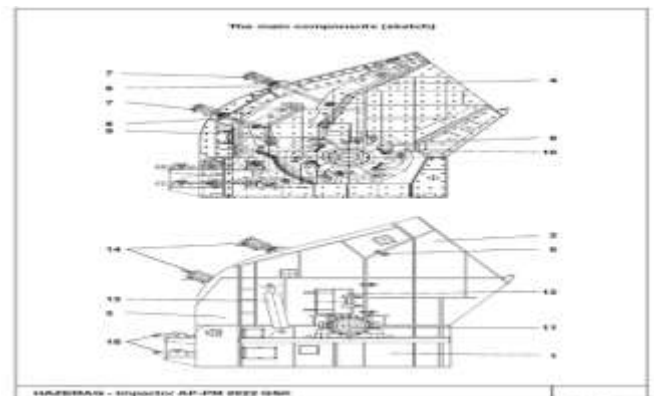

Figure 24 the Main Components of Limestone Crusher

**2. Hydraulic Unit Circuit:** First hydraulic oil is pumped into the filter to remove sediments and particles from oil under high pressure (max. 700 bar), after that oil passes through hoses and safety valves to the cylinders, and then the oil returns back to the tank. Figure 25 below shows the main components of the hydraulic oil station.

The main components of the hydraulic oil station are as follows (as shown in Figure 25): 1- Motor pump unit, 3- Valve block, 4- Front door, 5-Temp- and level switch, 6-Return line filter, 7- Filler- and breather filter, 8- Manometer, 9- Fluid level- and temperature gauge, 10- Cover for motor bracket, 11-Cover for filter bracket, 12- Sealing, 13- Sealing, 14- Exhaust filter, 26- Sealing ring, 30 -Check valve, 31- Check valve, 32- Adjustable male stud elbow, 34- Blanking cone, 36- Manometer, 37- Mini measuring nozzle, 101- Hose assembly, 102- Hose assembly.

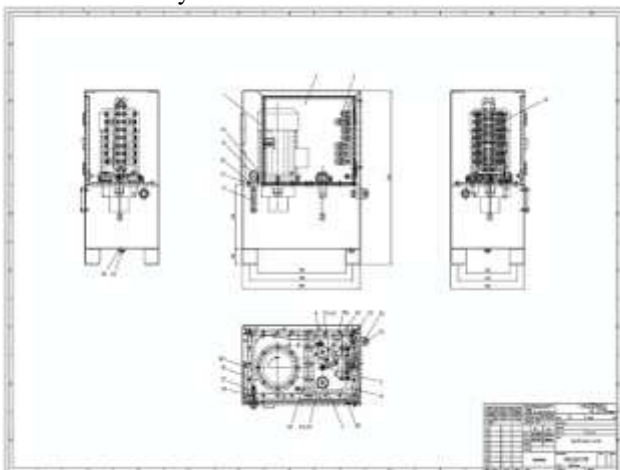

Figure 25 the Main Components of the Hydraulic Oil Station

#### 4.2.2 Raw Mill

A raw mill is the equipment used to grind raw materials into "raw mix" during the manufacture of cement. Raw mix is then fed to a cement, which transforms it into clinker, which is then ground to make cement in the cement mill. The raw milling stage of the process effectively defines the chemistry (and therefore, physical properties) of the finished cement, and has a large effect upon the efficiency of the whole manufacturing process.

Type of mill used is MPS 5000 B vertical mill. Vertical mill is a kind of grinding mill with high efficiency and low energy. Also, it is designed specially to solve the problem of low capacity.

**1. Function of Raw Mill and Grinding Process:** The MPS vertical roller mill is an air-swept vertical roller mill consisting of several constructional components. The main components - mill and classifier - form a single and compact unit. The principal feature of the MPS roller mill are three stationary grinding rollers which roll on a slowly rotating grinding plate. Together with one pressure, frame and three pull rods the

grinding rollers form a statically determined system which provides a uniform load distribution over the grinding bed and the segmented thrust bearing of the gearbox. Each grinding roller is flexibly connected to the pressure frame by means of a pressure yoke, which allows lateral rocking movements of the grinding rollers. This flexibility of movement and the pneumatic suspension of the tensioning system ensure an optimum adjustment of the grinding rollers to the grinding bed. The material, carried in by the feeder, is drawn in and crushed between grinding rollers and grinding plate. The forces required for the grinding are produced by pressing the grinding rollers onto the grinding plate. The contact pressure is created by a hydro-pneumatic tensioning system and can be varied during operation if necessary. The material is ground and conveyed toward the ported air ring by compression and shear. The gas flowing up through the ported air ring mixes with the material and so forms a rotating fluidized bed above the ported air ring. The coarser particles fall back onto the grinding plate and undergo again the grinding process.

The fine-ground particles are caught by the gas stream and carried up to the classifier. In the separation zone a rotating separating wheel separates the material into fine finished product and coarse particles (grits). The separating wheel is fitted with a variable speed drive to adjust the rotation speed to the required finished product fineness. The separated finished product is carried by the gas stream to the dust collector arranged after the mill. The coarse material falls back onto the grinding plate and is taken back into the grinding process. Figure 26 below shows the raw mill components and the grinding process.

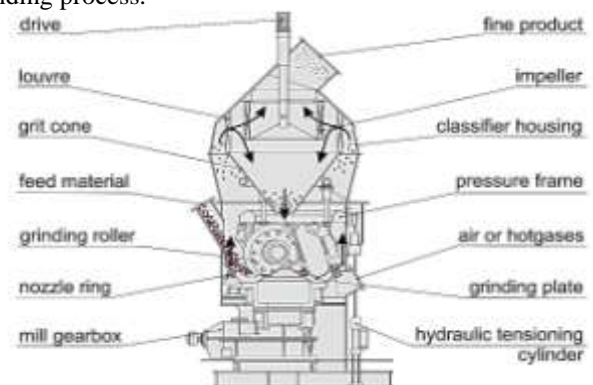

Figure 26 the Raw Mill Components and the Grinding Process

#### 4.2.3 Hydraulic Tensioning System

The contact pressure required for the grinding rollers is created by a hydro pneumatic tensioning system. The pressure frame, which has the shape of an equilateral triangle, transmits the forces created by the tensioning system onto the pressure yokes with the grinding rollers. Fitted to the ends of the pressure frame are the pull rods which transmit the forces from the hydraulic tensioning cylinders.

The three hydraulic tensioning cylinders are supplied with oil by one hydraulic unit which also produces the pressure required for the pre-tensioning of the grinding rollers. Each

hydraulic tensioning cylinder is fitted with a bag-type pressure accumulator filled with nitrogen gas which absorbs the shocks and vibrations occurring during mill operation. The hydro-pneumatic tensioning system is designed in such a way that the grinding rollers can be lifted for start-up purposes.

**1. Hydraulic Tensioning Components:** Figure 27 below shows the hydraulic tensioning system. The main components of hydraulic tensioning system are: 1- Oil supply system (pumps, filters, valves etc.), 2- Hydraulic cylinder, 3- Hydraulic bladder accumulator, 4 – Pull Rod, 5- Articulation head.

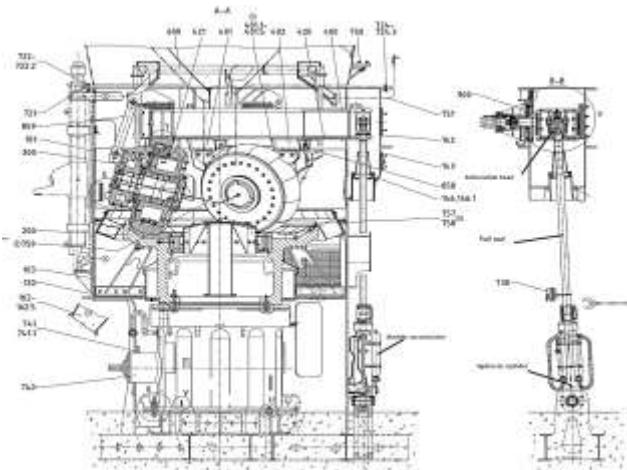

Figure 27 Hydraulic Tensioning System

#### 4.2.4 Rotary Kiln

**1. Work Principle of Rotary Kiln:** Rotary kiln is made of steel plate, and inside the kiln body refractory lining is inserted, which keeps specified inclination with horizontal line. Three tires are supported by supporting device around the tire at feed end, which uses tangential spring plate to fix big gear, under which a pinion is meshing with. During normal operation, the rotary kiln is driven by main motor through main reducer to transmit power to open gear.

Material is fed into kiln from kiln tail. Due to the slope and rotation of the cylinder, the material makes a composite motion—it rolls in circumferential direction and at the same time moves in axial direction. After sintering process, the material is calcined in cement clinker and discharged into cooler machine through kiln head hood. Figure 28 below shows the rotary kiln.



Figure 28 the Rotary Kiln

**2. Hydraulic Thrust Device (HTD):** The automatic hydraulic thrust device (HTD) controls the kiln's axial motion. It counteracts the slope of the kiln and ensures uniform use of the contact surfaces between tires and supporting rollers, as well as the girth gear and pinion. The hydraulic thrust device is designed to take up the full axial load of the kiln, so skewing of the support rollers is not needed. The result is smooth operation with improved life time for rolling components.

**3. Hydraulic Thrust Device Main Components:** Figure 29 below shows the hydraulic thrust device main components.

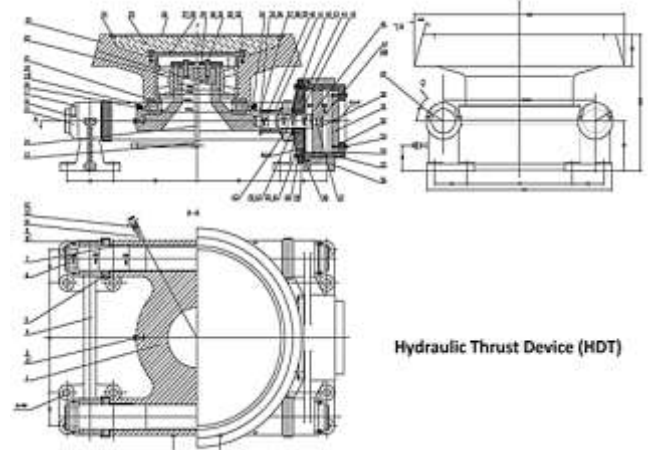

Figure 29 the Hydraulic Thrust Device Main Components

1- Thrust roller, 2- Hollow Shaft, 3- Hydraulic Cylinder, 4- Oil Supply System (Pumps, filters, accumulator, etc.), 5- Roller Bearings, 6- Axis

#### 4.2.5 Clinker Cooler

The function of clinker cooler is to cool the material coming out from rotary kiln using fresh air produced from large fan in high volume and pressure.

In Atbara cement the outlet material temperature nearly 1400 °C and it is directly cooled in a cooler, until the material becomes hard like stones then it is crushed in a hammer crusher to reduce size of stones. Figure 30 below shows the clinker cooler.

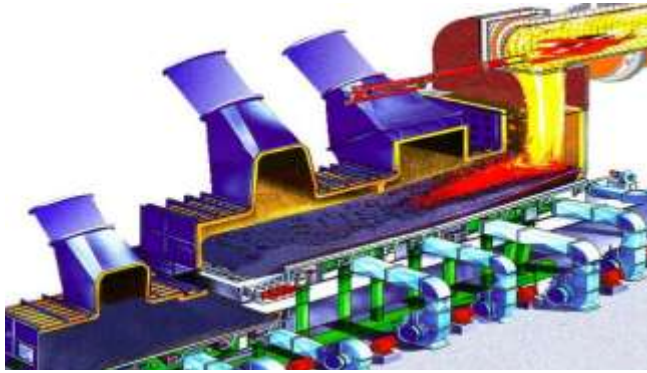

Figure 30 Clinker Cooler

**1. Main Components of Clinker Cooler:** The main components of clinker cooler are: 1- Walking lanes to transport material from inlet to discharge side of cooler, 2- Cooling fans disturbed at lengthwise of cooler, 3- Hydraulic cylinders to move walking lanes with material transport towards the end or beginning of cooler, 4- Clinker Crusher

**2. Hydraulic Components of Transport System:** 1- Electro – Motor Pump Station; 2- Oil tank and all components required for maintaining oil quality such as oil cooler, filtration, heating and water separation system; 3- Control blocks include all valves required for controlling movements; The proportional direction valve is operated in accordance with directional and speed value sent by the local control; 4- Hydraulic cylinders: translate the hydraulic energy into the motion energy of the transport lanes.

## V. MALFUNCTION OF HYDRAULIC SYSTEM IN CEMENT PLANT & SUGGESTED SOLUTIONS

### 5.1 Lime Stone Crusher

The correct functioning and service life of a hydraulic unit – irrespective of the sphere of application is influenced largely by careful maintenance and correct handling.

The following points are some malfunction which occurs in the hydraulic system of limestone crusher: 1. Flow rate is too low due to Pump defect or there is high temperature on the pump; 2. Over Flow losses due to Misadjusted in setting valves; 3. Due to contamination, valves don't switch or control; 4. Worn or damage hydraulic cylinder (Seals, Piston, etc.); 5. Accumulator defect or has lost charge; 6. Pressure reducing relief or unloading valve worn out or damaged; 7. Pump drive motor turning in wrong direction.

To avoid the previous malfunctions so as to increase the life time of the crusher, the instructions below should be followed:

1. Cleanliness of the unit is of paramount importance, all connections (pipes and tubes, etc.) are to be kept clean at all times; 2. Care must be taken regarding contamination of the hydraulic fluid. No dirt must be allowed to enter the accumulator during the filling operation, and filling must be carried out only in conjunction with the appropriate filter; 3. The choice of tubes and hoses is to be made according to the maximum operating pressure, the permissible hydraulic fluid

flow rate or permissible flow resistance and the type of hydraulic fluid used; 4. Pipes/tubes are to be bent where possible in a cold state and be de-burred cleanly. Heat-treated pipes/tubes are to be cleaned mechanically, and then pickled and a film of oil is applied. The ends of finished pipes/tubes are to be plugged until fitted during erection. Cleaning is to be effected using only non-fraying fabrics or special paper; sealing materials, such as hemp, filler or sealing tape are not permitted; 5. The proper installation of flexible coupling and alignment; 6. Care must be taken to ensure that the electrical connections to the electrical devices (solenoid valves, etc.) are correct; 7. A check must be carried out to ensure that all the hydraulic lines have been cleaned and fitted correctly, and that all screw connections and flanges have been tightened to the prescribed torques; 8. The hydraulic fluid is to be filled with the fluid level up to the top mark on the sight glass; 9. Switch on the pump drive motor to check the prescribed direction of rotation; 10. If there is an external control pump, it is to be put into operation. The same applies to any parallel flow filter units; 11. The correct functioning of the electro-hydraulic control should first of all be checked in accordance with the manufacture control flow sheet by an electrician using the appropriate test instruments; 12. During the whole start-up phase, continuous checks are to be carried out. These includes: Checking the oil level in the tank, Checking the filter (change elements if necessary), Checking the pressures indicated on the meters, Checking the correct functioning of the cooling system, Checking the plant and lines for leaks, Listening for any unusual noises; 13. The fluid level in the sight glass is to be checked regularly, and the hydraulic fluid topped up as necessary. Mixing of different kinds of hydraulic fluid is not permitted; 14. The filter elements are to be checked and replaced as necessary. Should the button of the contamination monitor pop out when the fluid is cold, it must be pushed back when the plant has warmed up to the operating temperature. If it pops out again, the filter element is contaminated. When a dynamic pressure gauge is used as a contamination meter, the indicated pressure of an operationally warm plant should lie within the green zone. If the pressure is in the yellow zone, then the filter element must be replaced at the next opportunity. Should the pressure lie in the red zone, the crusher must be shut down and the filter element changed. The readings of all contamination meters are accurate only for crusher running at the operating temperature; 15. The hydraulic fluid should be bled off at operating temperature. Old and/or contaminated fluid cannot be improved by adding new fluid. Re-filling is only to be effected using an appropriate filter; 16. Samples of hydraulic fluid should be taken at regular intervals and tested in an authorized laboratory for particle presence, type, size and amount, the results are to be recorded in the maintenance logbook; 17. The gas pressure in hydro-pneumatic accumulators is to be checked at regular intervals which are suited to the type of operation; 18. The piping/tubing system is to be checked for leaks; if necessary, the screw connections are to be tightened



when the plant is not under pressure; 19. Valves, pumps, motors, cylinders, etc. are to be checked for any leaks; defective parts or seals are to be replaced as necessary.

**5.2 Raw Mill**

As it is mentioned earlier, hydraulic Mechanism is used for grinding roller suspension system. So, the malfunction occurs in the following states: During tensioning, during raising, in automatic mode, and in local mode.

**1. The Main Basic Causes:** Quantity and pressure are not generated, Quantity and pressure are not maintained/are lost.

**2. The Basic Fault Sources can be identified in:** Valves are not properly installed, not being triggered properly, are stuck, have dirt build-up, and have leaky gaskets or seals; Pump does not generate the requisite pressure or convey at the requisite rate; Cylinder gaskets are defective.

**3. Common Malfunction Scenarios:** 1. Piston seals are defective: Wear and tear; Symptom: the tensioning pump is in continuous operation; Note: Cylinder pipe and return-flow line heat up, leakage oil from tank line. 2. Rectifier missing in valve plug of pressure drain valve: The diode lights up when triggered, yet the valve doesn't switch; Symptom: pressure build-up up to a capacity of 100 bar only as the oil current is being restricted while. 3. Flowing to the tank: Note: oil back-flow via tank line 28x3; switching sequence of the valves is incorrect; Symptom: no lifting pressure build-up.

**5.3 Causes of Malfunction and Troubleshooting:**

Table 2 below shows causes of malfunction and troubleshooting.

Table 2 Causes of Malfunction and Troubleshooting

Reason	Remedy
No pressure builds-up	Pressure relief valve malfunctioning or with dirt builds-up. Clean the pressure relief valve or replace it.
	Coupling broken. Replace the coupling
	Pump malfunctioning .Replace the pump
	Internal leaking .Look for source of leaking, remedy it
No pressure shown	Improper valve switching. Check the valve position according to the hydraulic circuit diagram and inspection and testing specification
	Pressure gauge and/or pressure malfunctioning. Replace pressure switch/pressure gauge
	Choker valve closed. Open the choker valve and clean it
	Directional valve not in the right switched Position. Correct switched position
	Directional valve malfunctioning or

	with dirt build-up. Check the plug (voltage), replace it if necessary, check for the right pin assignment; if necessary, clean valve
Built-up pressure too low	The setting of the pressure relief valves is wrong. Check the setting and correct it, if necessary
	Internal leakage. Check the valves and, if necessary, replace them
Pressure build-up insufficient	Valve switched incorrectly, has dirt build-up or is malfunctioning. Check the switched position; clean valve or replace it check the 1.2 mm orifice in upstream of the valve
	Cylinder leaking. Replace piston gasket, if necessary repair cylinder
No pressure present	Respective check valves leaking, with dirt build-up, connected wrong or not being triggered. Check routing of lines, connections against documentation; if necessary correct them.
	Dirt build-up or malfunction of valves. Check valve switching, remedy leaking, clean or replace valve as necessary
	Cylinder leaking. Replace piston gasket, if necessary repair cylinder
Pressure values present as specified in hydraulic circuit diagram, no upward movement	Directional valve not being switched correctly. Correct switched position
	Movement electronically restricted by position sensor system. Check setting
Pressure present, however not all cylinders are moved	Leaking, dirt build-up or malfunction of valves. Check the switched position and function of the valves; clean valves or replace them as necessary
	Piston gasket of respective cylinder is defective. Replace piston gasket
	Flow divider malfunctioning. Check flow divider
No or insufficient pressure	Malfunction or leaking of valve or in connection with leakage, dirt build-up or malfunctioning of valves. Check valve switching, remedy leaking, clean or replace valves as necessary; check



	switching sequence
	Safety valve of flow divider malfunctioning. Replace valve: (do not change valve setting, factory-set).
Pressure present, however no LOWER function	Flow-control valve Closed. Set flow-control valve
No pressure relieved when switching the facility off	Choker valve closed after pressure build-up. Open choker valve.
No pressure relief possible when valve is closed	Valve malfunctioning. Check valve.

#### 5.4 Kiln

Kiln is very sensitive equipment as well as it works 24 hours per day, so many malfunctions happened during operation as mentioned below:

**1- Pressure Failure, Deficit Pressure:** Table 3 below shows the causes and remedies of pressure failure and deficit pressure.

Table 3 the Causes and Remedies of Pressure Failure and Deficit Pressure

Causes	Remedy
Rotary direction wrong	Adjust the rotary direction
Leakage in pipes	Inspect and repair
Oil level low	Fill oil to the required level
Pipes connect wrongly	Reconnect them or repair
Oil pump lacks of repair, wears out	Repair it or place with new one

**2- Noise and Vibration:** Table 4 below shows the causes and remedies of noise and vibration.

Table 4 the Causes and Remedies of Noise and Vibration

Causes	Remedy
Air in pipe	Inspect oil level, ventilation, oil viscosity, blocking or not of the suction end in oil box, and do some dry run, discharge the air from gas discharging end for pressure measurement
Large pulsation in oil flow	Oil pump or valve parts blocking. Check and repair
Failure of mounting accuracy of motor to pump, big clearance or pipes do not fixed well	Adjusting the mounting accuracy, install a fixing frame in some place.

**3 - Actuating Mechanism Does Operate, Not operate uniformly or without Enough Speed:** Table 5 below shows the causes and remedies of the actuating mechanism, which does operate, not operate uniformly or without enough speed.

Table 5 the Causes and Remedies of the Actuating Mechanism which Does Operate, Not Operate Uniformly or Without Enough Speed

Causes	Remedy
Air in system	Discharge air from the air outlet(cylinder does several strokes of full distance movement, pump out the air)
Failure in guiding and lubrication of actuating mechanism	Repair the mechanism parts
Sealing parts too tighten, no flexibility	Adjusting

**4 - Technical Property of Main Parts:** Table 6 below shows the causes and remedies of the technical property of main parts.



Table 6 the Causes and Remedies of the Technical Property of Main Parts

Causes	Remedy
Oil pump, output capacity, output pressure	Failure in reaching the set values. Do some repair
Pressure of pressure gauges in stable values	If not, check the out end of adjusting spring, valve core blocking or not, pipes connect wrongly or not.
Direction change valve	
a. no actuation or way change	Check if the electric magnetic valve is qualified or not, unit parts suitable or not, if so, try to repair or replace.
b. flow regulating failure or not well done	Adjusting bolt in good situation or not, parts mating well or not, blocking and etc.
One-way valve failure	Sliding valve block in the valve body, no spring and etc., repair

Table 8 the Causes and Remedies of No Pressure or Insufficient Pressure in System

Reason	Remedy
Pump sucks air	Top up oil and Check oil used
High pump temperature	Repair or replace worn or defective Pump
	Check oil viscosity , if the viscosity is low replace the oil
	Check cooling in oil conditioning facility / check fins of oil-air cooler
Hydraulic output of pump too low	Restore basic pump setting if misadjusted
Overflow losses	Set valve pressure to basic setting in accordance with circuit diagram
	Relief valves do not close due to presence of dirt or defective parts. In this case Clean, determine defect, repair or replace
	Damaged cylinder bore; piston rod or piston seal should be repaired or replaced.
Valves do not switch or control	This happens due to contamination on the oil , so drain oil, clean system and components, fill in new oil
Air inclusions in the system cause irregular cylinder movements	Check ports and signals if defective valves, control signal missing or oscillating
	Flush system and vent again
	If cylinder sucks air via seal then check seal and replace, if necessary

### 5.5 Clinker Cooler

The following Malfunctions hints will facilitate fault locating and removal:

**1. Abnormal Noise in System:** Table 7 below shows the causes and remedies of the abnormal noise in system.

Table 7 the Causes and Remedies of the Abnormal Noise in System

Reason	Remedy
Air inclusions in oil ( foaming )	Top up oil and Check oil used
	Retighten or replace hose and fittings
	Check seals and filters and replace, if necessary
Mechanical vibrations	If there is vibrating pipelines then check mountings and retighten, if necessary
	Check coupling if Pump drive coupling loose
	Repair or replace defective or damaged Pump

**2. No Pressure or Insufficient Pressure in System:** Table 8 below shows the causes and remedies of no pressure or insufficient pressure in system.

**3. Hydraulic Cylinders Do Not Move:** Table 9 below shows the causes and remedies of hydraulic cylinders that do not move.



Table 9 the Causes and Remedies of Hydraulic Cylinders that Do Not Move

Reason	Remedy
Pump defective	Drive coupling of pump loose. Check it and Fix
	Pump defective or damaged. Repair or replace
Pump rotates in wrong direction	Incorrect motor sense of rotation. Change poles of electrical connections
Electric monitoring system for hydraulic cylinder movement defective	Internal damage, cable broken. Check and replace, if necessary
Mechanical damage / jamming	Check bottom part of cooler
Wrong valve setting	Valves misadjusted. Check settings and adjust
Proportional valve does not switch	Check electric control system

**4. Oil Temperature too high:** Table 10 below shows the causes and remedies when the oil temperature is too high. Table 10 the Causes and Remedies when the Oil Temperature is too high

Reason	Remedy
Overflow losses	Safety or relief valve setting too low. Correct the setting
	Safety valve does not close because of dirt or defective components. Clean, determine damage, repair or replace
Insufficient cooling	Oil supply has failed. Rectify fault
Inadequate cooling	Thermostat on oil tank defective. Check thermostat and replace, if necessary
	Set switching points correctly

Inadequate heat removal	Inadequate ventilation of hydraulic room Take measures ensuring adequate heat removal
Pump overheated	Pump is worn. Repair or replace
	Viscosity of oil used too low. Check oil used

**5. Leakage on Hydraulic Components:** Table 11 below shows the causes and remedies in the case of leakage on hydraulic components.

Table 11 the Causes and Remedies in the Case of Leakage on Hydraulic Components

Reason	Remedy
Contamination	Wear of components. Flush system and change oil
	Inadequate cleaning after repairs. Flush system and change oil
Seals defective	Seals incorrectly installed. Replace defective seals
Fittings insufficiently tightened	Retighten with correct torque.

## VI. CONCLUSIONS

### 6.1 Causes of Excessive Noise of Hydraulic Pump

The following charts are arranged in five main categories the heading of each one is an effect, which indicates malfunction on the system, for example if a pump is exceptionally noisy refer to chart 5.1 entitled excessive noise. The noisy pump appears in column (A) there under the main heading. In column (A) there are four probable causes for a noisy pump. The causes are sequenced according to the likelihood of happening or the ease of checking it. The first cause is cavitation and the remedy is "a". If the first cause does not exist, check for cause number 2 and so on. Chart 6.1 below shows the causes of excessive noise of hydraulic pump.

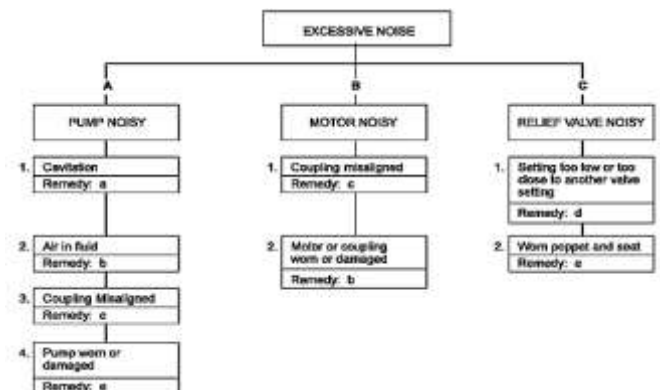
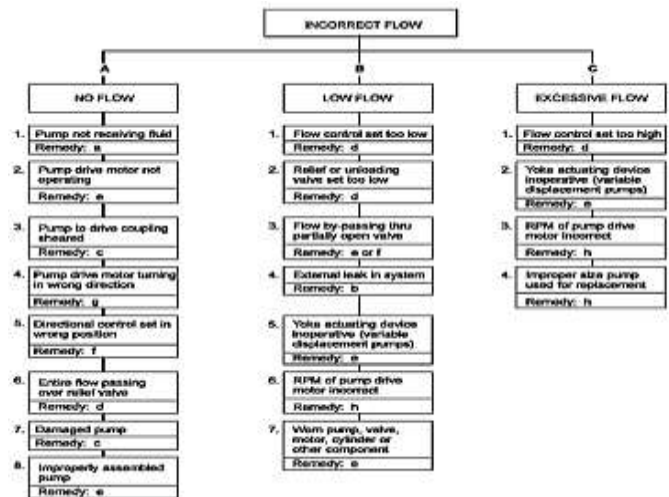



Chart 6.3 the Causes of Incorrect Flow



**Remedies:** a) Any or all of these points : replace dirty filters in solvent compatible with system fluid ; clean clogged inlet line , clean or replace reservoir breather vent ; change system fluid ; change to proper pump drive motor speed ; overhaul or replace supercharge pump ; fluid may be too cold . b) Any or all of these points: tighten leaking connections; fill reservoir to proper level, bleed air from system; replace pump shaft & seal. c) Align unit and check condition of seals, bearing and coupling. d) Install pressure gauge and adjust to correct pressure. e) Overhaul or replace.

Chart 6.1 Causes of Excessive Noise of Hydraulic Pump

### 6.2 Causes of Excessive Heat

Chart 6.2 below shows the causes of excessive heat.

Chart 6.2 the Causes of Excessive Heat



**Remedies:** a) Any or all of these points: replace dirty filters ; clean clogged inlet line ; clean or replace reservoir breather vent , change system fluid ; change to proper pump drive motor speed ; overhaul or replace supercharge pump . b) Any or all of these points: tighten leaking connections; fill reservoir to proper level, bleed air from system; replace pump shaft & seal. c) Align unit and check condition of seals, bearings; locate and correct mechanical binding; check for workload in excess of circle design. d) Install pressure gauge and adjust to correct pressure. e) Overhaul or replace. f) Change filters and system fluid if improper viscosity; fill tank to proper level. g) Clean cooler and/or cooler strainer, replace cooler control valve; repair or replace cooler.

### 6.3 Causes of Incorrect Flow:

Chart 6.3 below shows the causes of incorrect flow.

**Remedies:** a) Any or all of these points: replace dirty filters ; clean clogged inlet line ; clean or replace reservoir breather vent , change system fluid ; change to proper pump drive motor speed ; overhaul or replace supercharge pump . b) Tighten leaking connections. c) Check for damaged pump or pump drive; replace and Align coupling. d) Adjust. e) Overhaul or replace. f) Check position of manually operated controls; check electrical circuit on solenoid operated controls; repair or replace pilot pressure pump. g) Reverse rotation. h) Replace with correct unit.

### 6.4 Causes of Faulty Operation:

Chart 6.4 below shows the causes of faulty operation.

Chart 6.4 the Causes of Faulty Operation

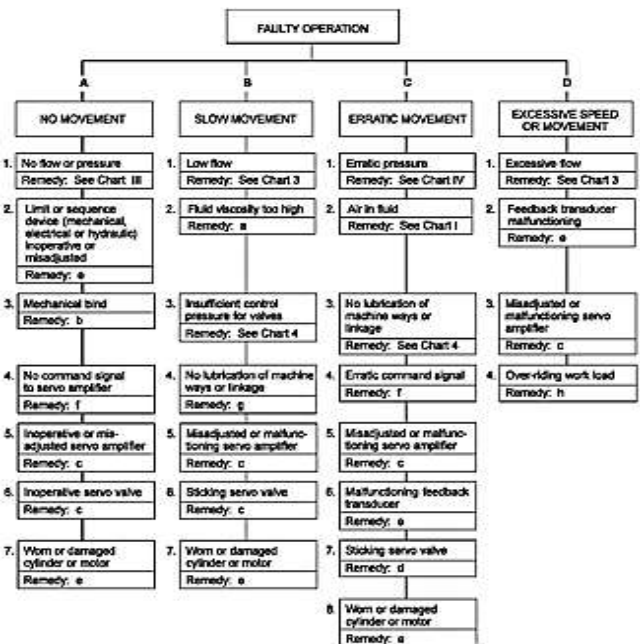



**Remedies:** a) Fluid may be too cold or should be changed to clean fluid or correct viscosity. b) Locate bind and repair. c) Adjust, repair or replace. d) Clean and adjust or replace; check condition of system fluid and filters. e) Overhaul or replace. f) Repair command console or interconnecting wires. g) Lubricate. h) Adjust, repair or replace counterbalance valve.

## VII. REFERENCES

- [1]. "The domestic economy: Portuguese company is to build a cement factory - Country Report Angola March 2006 Country Report". Eiu.ecnext.com. Archived from original on 2011-07-10. Retrieved 2011-02-22.
- [2]. "Das Portal der Republik Angola". Botschaftangola.de. Archived from the original on 2011-01-20. Retrieved 2011-02-22.
- [3]. "Organization Record - Benin". afdevinfo.com.
- [4]. "About Africa Action / Africa Policy E-Journal / Burundi: Recent Documents". U.S. Committee for Refugees. January 15, 1997. Archived from the original (Press Release) on 2008-08-20.
- [5]. "About PPC > Company Structure" Archived 2011-09-25 at the Way back Machine. PPC.co.za.
- [6]. "Bienvenue sur". Apanews.net. Retrieved 2011-02-22. ^ "Nubian Cheetah: Korean-led group to build Cameroon cement plant". Nubiancheetah.blogspot.com. 2008-01-22. Retrieved 2011-02-22.
- [7]. "Central African Republic: Cement - Bangui Negotiates Supply". Emmanuel Kendemeh, AllAfrica.com, 28 April 2008.
- [8]. "The Mineral Industry of Congo (Brazzaville) in 2005" (PDF). Retrieved 2011-02-22.
- [9]. "Italcementi Group". Italcementigroup.com. Archived from the original on 2009-03-30.
- [10]. "China New Era International". Cnme.com.cn. Archived from the original on 2011-07-07. Retrieved 2011-02-22.
- [11]. Ethiopian reporter adds fortune, 2017. ^ "Areas & Countries" Africa-Mediterranean Basin "Africa". Heidelberg Cement Global.
- [12]. "The Mineral Industry of Gabon in 1999" (PDF). Retrieved 2011-02-22.
- [13]. "Editorial: What must be done on cement price crisis? | Press Review 2007-04-03". Ghanaweb.com. 2007-04-03. Retrieved 2011-02-22.
- [14]. "President inaugurates Diamond Cement Factory". GNA - Ghana News Agency. 29 September 2004.
- [15]. "Information Gateway to Ghana - . Let's make Ghana ". Ghana Today. Archived from the original on 2011-01-02. Retrieved 2011-02-22.
- [16]. "Ghana - Heidelberg Cement in Africa". Heidelbergcement.com. 2006-12-04. Retrieved 2011-02-22.
- [17]. "Ghacem increases production capacity" source: thebftonline.com. 2012 November 30.
- [18]. "The Mineral Industries of Guinea, Liberia, and Sierra Leone". Thomas R. Yager. Section 17.4 U.S. Geological Survey Minerals Yearbook. 2002. Retrieved 2011-10-10.
- [19]. "Athi River Mining — Mon, February 21, 2011 ~ Nairobi Stock Exchange, Portfolio Manager, Personalized Information, Superior Analysis Tools, News, Nairobi Stock Exchange". Mystocks.co.ke. Retrieved 2011-02-22.
- [20]. Bamburi Cement Limited. Lafarge.
- [21]. Railways Africa editor (2009-09-14). "New Kenya Cement Railway". Railways Africa. Retrieved 2011-02-22.
- [22]. Railway Gazette International June 2012, p31.
- [23]. "Rail, Rail Anchors, Fasteners and Sleepers Gallery". Railway Technology. Retrieved 2011-02-22.
- [24]. "The Manufacture of Cement, Lime and Plaster in Malawi, 2019 Report".
- [25]. "Lafarge Cement Ltd. (Port Louis, Mauritius) | Port Louis, Mauritius | Company Profile, Research, News, Information, Contacts". Goliath.ecnext.com. Retrieved 2011-02-22.
- [26]. Quelles perspectives pour le marché du ciment au Maroc.
- [27]. "Cimentos de Mozambique". CimPor.pt.
- [28]. "Mozambique News Agency - AIM Reports". Poptel.org.uk. Retrieved 2011-02-22.
- [29]. "Namibia: Cement Factory to Be Opened at Karibib". 16 July 2008. AllAfrica.com.
- [30]. "Cement plant Ohorongo". Economist.com.na. Archived February 13, 2012, at the Wayback Machine.
- [31]. "German firm to construct US\$350 million Cemtn Plant in Namibia". AfriquenLigne.fr. August 14, 2008. Archived August 17, 2008, at the Way back Machine.
- [32]. Marketplace. Namibian.com.na. August 2007. Archived 2007-08-15 at Archive. Today.
- [33]. "Namibian Rail Developments near Otavi". Railways Africa. March 15, 2010. Archived from the original on June 29, 2010. Retrieved 2011-02-22.
- [34]. BikSpec [permanent dead link]. bikspec.com.
- [35]. <http://www.railwaysafrica.com/blog/2011/10/dangote-group-plans-rail-connections-in-nigeria/>.
- [36]. "worldwide < Profile < Group". Lafarge. Retrieved 2011-02-22.
- [37]. "Ashaka Cement". Dangote-groupng.com.com.
- [38]. "Home: Lafarge - Cement, concrete, aggregates and gypsum". Lafargewapco.com. Retrieved 2011-02-22.
- [39]. "Nigerian Cement". Dangote-groupng.com.
- [40]. "Rwanda: Second Cement Factory Planned". John Gahamanyi, 18 December 2007. AllAfrica.com.(subscription required).



- [41]. "Cement Works | Societe Commerciale De Transport ET D'Industrie - Suarl (Dakar)". Senegalphonebook.com. Retrieved 2011-02-22.
- [42]. Publications, Europa (2003). Africa South of the Sahara 2004 - Google Books. ISBN 9781857431834. Retrieved 2011-02-22.
- [43]. "Cement Report 06/07" Archived 2010-11-29 at the Wayback Machine (PDF). Polysius AG, ThyssenKrupp Technologies.
- [44]. "Archived copy". Archived from the original on 2015-07-15. Retrieved 2015-07-15.
- [45]. "(Cement, Lime, Aggregates) - Welcome to the PPC website". PPC. Retrieved 2011-02-22.
- [46]. "The Mineral Industry of Sudan" (PDF). Thomas R. Yager. USGS.gov. 2001.
- [47]. Article. SiloBreaker.com [dead link].
- [48]. "Mbeya Cement - Company profile & brands". Transnationale.org. Retrieved 2011-02-22.
- [49]. "Cement Works - Togolese Republic". Togophonebook.com. Retrieved 2011-02-22.
- [50]. "Projects - Togo: Cimao Regional Clinker Project". Web.worldbank.org. Retrieved 2011-02-22.
- [51]. "Tunisia chooses French bank to carry out privatization of two cement factories". Arabicnews.com. Archived from the original on 2012-02-14. Retrieved 2011-02-22.
- [52]. "Cement Industry in Tunisia". AUCBM.org. 2009. Archived from the original on 2011-05-27. Retrieved 2011-06-29.
- [53]. "Current Capacity at 1,000,000 Metric Tonnes Annually". Archived from original on 2013-12-02. Retrieved 2013-11-26.
- [54]. Cement. Open Society Institute. [Dead link].
- [55]. "Lafarge Cement Zambia Plc: LUS: LAFARGE quotes & news - Google Finance". 2010-06-23. Retrieved 2011-02-22.
- [56]. "Lafarge Cement Zimbabwe Limited: ZIM: LACZ quotes & news - Google Finance". Retrieved 2011-02-22.
- [57]. Basic of Hydraulic System, Publisher: CRC Press 2008, Author: Qin Zhang.
- [58]. Practical Hydraulic Systems: Operation and Troubleshooting for Engineers and Technicians, Publisher: Elsevier Science 2005, Author: Ravi Doddannavar, Andries Barnard, Jayaraman Ganesh.
- [59]. Hydraulic Systems Analysis, Publisher: Macmillan Education, Limited, Author: John Stringer.
- [60]. Parker Hannifin, Hydraulic & Pneumatic Company-Germany [www.Parker.com](http://www.Parker.com).
- [61]. HYDAC, Hydraulics Company, Germany, [www.HYDAC.com](http://www.HYDAC.com).
- [62]. HAZEMAG Mining & Cement Industry - Germany – [www.HAZEMAG.com](http://www.HAZEMAG.com).
- [63]. CLADUIS PETERS Technology -Germany – [www.claudiuspeters.com](http://www.claudiuspeters.com).
- [64]. Gebr Pfeiffer, Raw Mill & Coal Mill Manufacturing – Germany [WWW-Gebr.pfeiffer.com](http://WWW-Gebr.pfeiffer.com).
- [65]. Toro University Technical Training, Hydraulics Circuits, Components, Schematics, Hydrostatic Drives and Test Equipment.
- [66]. BASIC HYDRAULIC SYSTEMS AND COMPONENTS Sub course Number AL 0926 EDITION a US Army Aviation Logistics School Fort Eustis, Virginia 23604-5439 4Credit Hours Edition Date: September 1994.
- [67]. Technical Topic, Hydraulic System Care & Maintenance, 2009.
- [68]. W. L. Greer, et al., "Portland Cement", Air Pollution Engineering Manual, A. J. Buonicore and W. T. Davis (eds.), Von Nostrand Reinhold, NY, 1992.
- [69]. U. S. And Canadian Portland cement Industry Plant Information Summary, December 31, 1990 ,Portland Cement Association, Washington, DC, 1991.
- [70]. J. S. Kinsey, Lime And Cement Industry - Source Category Report, Volume II, EPA-600/7-87- 007 ,U. S. Environmental Protection Agency, Cincinnati, OH, February 1987.
- [71]. Written communication from Robert W. Crolius, Portland Cement Association, Washington, DC, to Ron Myers, U. S. Environmental Protection Agency, Research Triangle Park, NC. March 11, 1992.
- [72]. Written communication from Walter Greer, Ash Grove Cement Company, Overland Park, KS, to Ron Myers, U. S. Environmental Protection Agency, Research Triangle Park, NC, 1993.

# IJEAST

INTERNATIONAL JOURNAL  
OF ENGINEERING APPLIED SCIENCE  
AND TECHNOLOGY

## ABOUT IJEAST

International Journal of Engineering Applied Science and Technology (IJEAST) is a peer-reviewed, open access journal that publishes high-quality research papers in the field of Engineering, Applied Science and Technology.

IJEAST aims to provide a platform for researchers, academicians, and professionals to share their innovative ideas, research findings, and practical experiences with the global scientific community.

## FOCUS AREAS

- Engineering
- Applied Science
- Technology
- Innovation & Development
- Interdisciplinary Studies



### PEER REVIEWED

All submissions are rigorously peer reviewed to ensure quality.



### OPEN ACCESS

Free and unrestricted access to research for all.



### GLOBAL REACH

Connecting researchers and professionals worldwide.



### TIMELY PUBLICATION

We ensure a swift and efficient publication process.



For more information, visit our website

[www.ijeast.com](http://www.ijeast.com)



INTERNATIONAL JOURNAL  
OF ENGINEERING APPLIED SCIENCE  
AND TECHNOLOGY

✉ [editor@ijeast.com](mailto:editor@ijeast.com)

🌐 [www.ijeast.com](http://www.ijeast.com)

📍 India



2455-2143