



# IJEAST

INTERNATIONAL JOURNAL  
OF ENGINEERING APPLIED SCIENCE  
AND TECHNOLOGY



**VOLUME : 2    ISSUE : 3    Print / Issue Publication Date: 09-Mar-2017**



**ISSN : 2455-2143**



Indexed In



[WWW.IJEAST.COM](http://WWW.IJEAST.COM)

[editor@ijeast.com](mailto:editor@ijeast.com)



# A REVIEW ON THE REMOTE SENSING IMAGES BASED ON OBJECT DETECTION USING DEEP BELIEF NETWORKS

Er.Amarjot Kaur

M.Tech Scholar Department of Computer Science & Engineering, Amritsar College of Engineering & Technology, Amritsar

Er.Navleen Kaur

Associate Professor, Department of Computer Science & Engineering, Amritsar College of Engineering & Technology, Amritsar

**ABSTRACT**— This paper represents the object detection which has been one of the hottest issues in the field of remote sensing image analysis. It is of vital importance for object dynamic surveillance and other applications. So far, object detection has been widely researched. It shows an efficient coarse object locating method based on a saliency mechanism. The method could avoid an exhaustive search across the image and generate a small number of bounding boxes. After that, the trained DBN is used for feature extraction and classification on sub-images. The general purpose of this document is actually to research the a variety of strategies based on object detection and it also demonstrate the accuracy and efficiency of object detection framework using a saliency prior and DBNs for remote sensing images.

**Keywords**— Image segmentation, Object detection, Deep belief networks, Saliency.

## I. INTRODUCTION

Environmentally friendly keeping track of wants, preservation desired goals, spatial organizing enforcement, and also ecosystem-oriented all-natural assets administration, to list just a few drivers, give significant desperation to enhancing business options that may draw out concrete data via distant realizing data. The actual work connected with satellite TV for pc data era, including the Territory sitting and also SPOT satellites or the ASTER and also MODIS tools, have become crucial in worldwide and also local scientific studies connected with biodiversity, nature preservation, foodstuff safety, deforestation affect, desertification keeping track of, and various application fields. Remote control detecting imagery of a giant selection of space or room carried and air-borne receptors presents a lot of info with regards to all of our earth floor intended for world and comprehensive analysis, adjust recognition and monitoring. Potent indicate processing solutions are generally developed to explore the invisible info around state-of-the-art sensing unit data. REMOTE realizing photographs bought by simply multispectral alerts, like the widely used Landsat Thematic mapper (TM) indicator, have shown his or her performance within the planet watching with interest (EO) applications. In general, the comparatively few purchase programs that characterizes multispectral

alerts might be enough for you to discriminate amongst several land-cover courses (e.g., forestry, water, vegetation, urban areas, etc.). Nonetheless, his or her discrimination power is usually limited when different kinds (or conditions) of the identical kinds (e.g., a variety of forest) should be recognized. Hyper spectral alerts enable to handle the following problem. These alerts tend to be characterized by a really substantial spectral decision that typically translates into a huge selection of watching with interest channels.

## A. OBJECT DETECTION

Object detection is probably the fundamental responsibilities within far off smell photo analysis. It can be critical pertaining to item active detective as well as other applications. A frequent paradigm to cope with this condition is definitely to coach item sensors of which operate on subscription photos in addition to implement most of these sensors in the inclusive approach all over all locations in addition to scales.

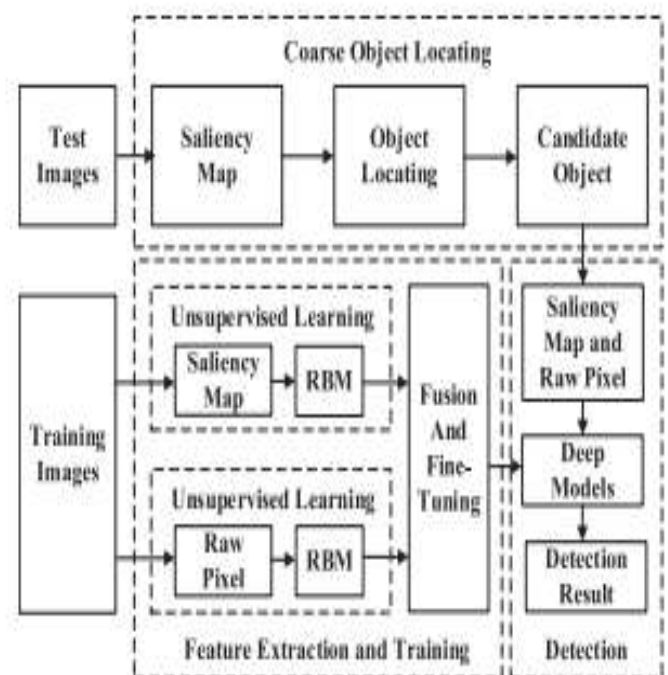

Fig. 1. Object Detection Framework



A structure is often broken into 2 parts, i.e., it level as well as the prognosis stage. The training provides the without supervision aspect understanding as well as the discriminative fine-tuning. A disjoint photograph selection is employed while it arranged to coach some sort of DBN. For the prognosis level, a coarse object tracking down way is handled upon test images to obtain a small number of bounding cardboard boxes while object candidates. As a final point, your sub images usually are indexed by your DBN.

## **B. IMAGE SEGMENTATION**

Image segmentation can be a as well as difficult difficulty as well as a crucial first step in image analysis along with high-level image presentation as well as comprehension including software eyesight, item recognition, as well as health imaging. The aim of image segmentation will be to partition a photo in to a pair of disjoint zones having uniform as well as homogeneous capabilities including depth, color, sculpt or texture, etc. The look segmentation methods may be split up into three categories: thresholding, clustering, fringe diagnosis as well as area extraction. In this particular report, the clustering based mostly method for image segmentation will likely be considered.

## **C. SALIENCY**

The Saliency regarding a product or a particular person or a pixel – will be the quality during which the idea shines comparative to its neighbors. Saliency detection is regarded as a procedure that will makes it possible for learning and you surviving by simply enabling microorganisms to concentrate their own limited perceptual assets about the majority of essential part regarding the free sensory data. The item normally emanates from differences between objects as well as their town, for instance a purple dept.of transporation in the middle of whitened dots, a playful information gauge of your addressing device, or a high in volume sounds throughout a normally peaceful environment. Saliency detection is normally learned has gone south the particular graphic technique, but related components are employed in alternative sensory systems.

## **II. MARKOV RANDOM FIELD**

Markov network or undirected graphical model is actually a established of unique variables acquiring a Markov Property based on an undirected graph. Basically, a unique field is said for you to be Markov unique field whether or not it satisfies Markov properties. MRF is related to a Bayesian Network included in the representation associated with dependencies; the variances staying in which Bayesian communities are instructed, while Markov communities will be undirected and might be cyclic. So, a new Markov network can certainly symbolize selected

dependencies that your Bayesian network are not able to (such since cyclic dependencies); conversely, it wouldn't symbolize selected dependencies that your Bayesian network can certainly (such since dependencies).

## **2.1 Morphological Operations**

Morphology can be a broad list of photo control expeditions which practice photos based on shapes. Morphological expeditions usually are people who use a constructing component for an suggestions photo, generating an end result photo the exact same size. Within a morphological procedure, the cost of every single pixel inside end result photo can be based on a comparison of the attached pixel inside suggestions photo featuring its neighbors. By simply seeking the configuration of your neighborhood, you can build some sort of morphological procedure that's responsive to unique forms inside suggestions image. The most basic morphological expeditions usually are dilation and erosion.

## **III. DEEP BELIEF NETWORKS**

A DBN can be a multilayer generative unit with a number of sheets associated with minimal Boltzmann devices (RBMs), wherever every part encodes stats dependencies one of several models while in the part under it. Multilevel functions could be produced as soon as every part with the generative part wise without supervision understanding algorithm. Your unit has become applied with results in a number of personal computer imaginative and prescient vision tasks. DBN for airplanes prognosis inside rural feeling images will be employed because instruction samples. Nonetheless, the particular spatial sequence associated with area functions is known as more important, in particular for the article inside rural feeling images. Heavy notion systems (DBN) will be generative Heavy notion community models with numerous sheets associated with secret explanatory things in addition to a greedy layer-wise without supervision understanding algorithm. Your building block of an DBN can be a probabilistic unit termed as minimal Boltzmann unit (RBM).

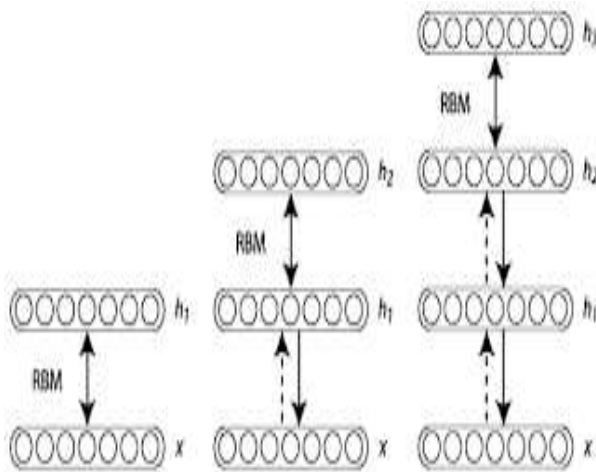

Fig. 2. Deep Belief Network

### A. Restricted Boltzmann Machine (RBM)

Restrained Boltzmann device (RBM), accustomed to symbolize 1 part with the model. Restrained Boltzmann equipment are usually useful simply because inference is not hard in them and since they have been productively made use of while foundations regarding coaching much deeper models. Many of us 1st demonstrate that will including disguised, items yields stringently improved modeling strength, while another theorem implies that RBMs are usually common approximates connected with distinct distributions. A new method for coaching a deep perception community which could create an estimate with the name info granted merely the sensor / probe data. We start while using the intuition that will a deep community qualified with concatenated sensor-label advices understands a reflection that will records disguised. Hidden relationships among the two kinds of web data, allowing for this decoder level in order to effectively reconstruct the two sensors along with labeling granted these kind of discussed features. Many of us as a result hypothesize whenever a new encoder can be conditioned to create disguised. Attributes out of sensor-only advices that will is the same to prospects manufactured by the initial community any time granted sensors concatenated with labeling, then a decoder out of the initial community could be used to reconstruct labeling from your disguised. Constraints manufactured by the revolutionary, sensor-only encoder.

## IV. RELATED WORK

N. Dalal et al. [1] proposes a affect for each phase of your calculation upon functionality, final that fine-scale gradients, excellent positioning binning, comparatively coarse spatial binning, in addition to high-quality regional form a contrast normalization around the overlap golf descriptor hindrances are crucial for great results. The modern approach allows near-perfect

divorce upon an original MIT walking database. G. Hinton et al. [2] shows utilizing “complementary priors” to help eliminate the explaining-away results that will make inference difficult around densely connected notion fabric tailgate enclosures that have a lot of concealed layers. Making use of complementary priors, many of us get a quick, money algorithm formula that could learn serious, aimed notion cpa affiliate networks one particular level at any given time, provided the most notable two levels sort the undirected associative memory. The fast, money algorithm formula is actually accustomed to initialize a new more slowly finding out method that fine-tunes a weights utilizing a contrastive model from the wake-sleep algorithm. Yoshua Bengio, et al. [3] proposed Complication concept associated with build passionately suggests that serious architectures can easily considerably more streamlined (sometimes exponentially) compared to cursory architectures, in terms of computational components needed to stand for quite a few functions. On the other hand, until finally a short while ago it was not obvious the way to practice this kind of serious cpa networks, due to the fact gradient-based search engine marketing beginning with unique initialization usually typically get stuck in inadequate solutions. Hinton et al. [4] introduced the greedy layer-wise unsupervised understanding criteria pertaining to Strong Thinking Cpa networks (DBN), the generative style many different tiers with secret causal variables. Damaging credit these search engine optimization dilemma, many of us study this criteria empirically and check out variations to raised realize it's achievements and expand them so that you can instances when the particular inputs are usually steady or in which the shape of your suggestions circulation seriously isn't unveiling adequate regarding the adjustable to generally be believed in the monitored task. Xian Sun et al. [5] proposed a new fresh process to resolve the condition connected with sensing geospatial items contained in high-resolution far off feeling graphics automatically. Each photo will be displayed as being a segmentation pine by applying a new multistage segmentation algorithm. The actual trees tend to be matched to help pick the maximally matched subwoofer trees, denoted when typical subcategories. And then, many of us organize most of these subcategories to understand this inserted taxonomic semantics connected with items classes that allow classes being characterized recursively, and exhibit equally precise and implicit spatial construction connected with categories. Marc'Aurelio Ranzato et al.[6] Proposed the use one of the best, pixel-level, generative models of natural images-a gated MRF-as the lowest level of a deep belief network (DBN) that has several hidden layers. It shows that the resulting DBN is very good at coping with occlusion when predicting expression categories from face images, and it can produce features that perform comparably to SIFT descriptors for discriminating different types of scene. The generative ability of the



model also makes it easy to see what information is captured and what is lost at each level of representation. Ming-Ming Cheng et al.[7] Used a generic objectless measure to produce a small set of candidate object windows, has been shown to speed up the classical sliding window object detection paradigm. It observes that generic objects with well-defined closed boundary can be discriminated by looking at the norm of gradients, with a suitable resizing of their corresponding image windows in to a small fixed size. Toronto has acquired considerable expertise at training RBMs and this guide is an attempt to share this expertise with other machine learning researchers. Hao Sun et al.[8] offered Automated detectors with regard to targets having intricate appearance within high-resolution out of the way detecting photographs is a challenging task. In this paper they offer a fresh detectors design according to spatial thin coding bag-of-words (BOW) (SSCBOW) type to fix this specific problem. What's more, as a substitute of *Ok*-means with regard to visual-word encoding while in the common BOW type, thin coding is shown gain a reduced reconstruction error. Ge Liu et al. [9] proposed Computerized jet acknowledgement throughout high-resolution satellite television graphics has lots of crucial applications. As a result of selection and also complexity connected with fore-/background, acknowledgement making use of pixel-based procedures often isn't going to complete well. During this letter, all of us propose to your girlfriend a fresh procedure integrating your high-level information on the contour prior, which usually is regarded as the coarse-to-fine process. Finally, your factors of your segmentation consequence are usually immediately applied to validate jet sort having two *ok*-nearest neighbors measures. Xueyun Chen et al. [10] offered planes detection is actually a complicated job with high-resolution out of the way small illustrations or photos,

because of the varying sizes, colorations, orientations and complex backgrounds. Within this papers, a powerful airplane detection strategy is suggested which usually particularly finds the object through outputting it is geometric centre, inclination, position. To relieve a influence connected with historical past, multi-images as well as gradient impression and grey thresholding illustrations or photos connected with the object had been insight into a Strong Thinking Internet (DBN), which had been pre-trained very first to understand functions and then fine-tuned through back-propagation to render a substantial detector. Clement Farabet et al. [11] described scene labels consists of labels every pixel in a image by using the category regarding the object the item belongs to. It states an approach in which relies on a multiscale convolution community properly trained coming from uncooked pixels so that you can extract dense attribute vectors in which encode regions of numerous sizes centered on every pixel. The method reduces the requirement for manufactured options, and delivers an effective rendering in which records feel, design, and contextual information. Wanceng Zhang et al. [12] proposed a rotation invariant parts-based style to be able to recognize materials together with intricate contour around high-resolution distant realizing images. Specifically, the geospatial materials together with intricate contour are generally to begin with divided into a number of principal pieces, and also the framework information and facts between pieces is usually explained as well as governed around complete coordinates to own turn invariance in configuration. In the mean time, the offer variant of the piece in accordance with the item can also be explained in this model.

## V. V COMPARISON TABLE

Table 1: Comparison of Various Techniques

Ref No	Authors	Year	Technique	Features	Limitations
[1]	Ziming Zhang, et al	2014	BING: Binarized Normed Gradients	simple, fast, and high quality objectness measure by using BING	Bounding box might not localize the object instances as accurately as a segmentation region .
[2]	Ming-Ming, et al	2014	Image Spirit: Verbal guided image parsing.	Novel and natural interaction modality, large-scale quantitative evaluation.	Because of some architectural issues the solution is not scalable and efficient.
[3]	W. Zhang, et al	2014	Object Detection in High-Resolution Remote Sensing Images	Rotation invariant parts-based model to detect objects	The solution is not considered to be efficient
[4]	T. Gevers,, et al	2013	Selective Search for Object Recognition	Use of the powerful Bag-of-Words model for recognition	Evolutionary technique has not been considered.



[5]	C. Couprie, et al	2009	Scene Labeling	A multistage convolution network trained from raw pixels to extract dense feature vectors	A Meta heuristic technique has not been considered.
[6]	S. Xiang, et al	2009	Deep Belief Nets, multi-images	the multi-images help improve the detection precision of DBN than using only single-image	The solution is not considered to be efficient
[7]	X. Sun ,et al	2009	Coarse-to-Fine Shape Prior	Aircraft Recognition in High-Resolution Satellite Images	Because of some architectural issues the solution is not scalable and efficient.
[8]	Sun, Hao, et al	2009	Spatial Sparse Coding Bag-of-Words Model	Automatic Target Detection in High-Resolution Remote Sensing Images.	Some of the architectural issues considered to be ignored
[9]	E.Geoffrey ,et al	2010	Global Contrast	Salient Region Detection	An adaptive power control method to improve the network energy efficiency is ignored

## VI. CONCLUSION

An object detection frame- work using a saliency prior and DBNs for remote sensing images. The novel method is based on the learning method of DBNs. So this paper shows about the comparison of various techniques based on the object detection which shows that by using a visual saliency prior, which locates the object more precisely and more quickly. But still there are some issues that it has not considered the poor quality images like images with poor brightness. So in near future we will evaluate an efficient object detection using the Markov Random Field (MRF) and Deep Belief Networks based Image Segmentation.

## VII. REFERENCES

- [1] M.-M. Cheng, Z. Zhang, W.-Y. Lin, and P. Torr, "BING: Binarized normed gradients for objectness estimation at 300 fps," in Proc. IEEE CVPR, 2014, pp. 3286–3293.
- [2] Cheng, Ming-Ming, et al. "ImageSpirit: Verbal guided image parsing." ACM Transactions on Graphics (TOG) 34.1 (2014): 3.G.
- [3] W. Zhang, X. Sun, K. Fu, C. Wang, and H. Wang, "Object detection in high-resolution remote sensing images using rotation invariant parts based model," IEEE Geosci. Remote Sens. Lett., vol. 11, no. 1, pp. 74–78, Jan. 2014.
- [4] J. R. Uijlings, K. E. van de Sande, T. Gevers, and A. W. M. Smeulders, "Selective search for object recognition," Int. J. Comput. Vis., vol. 104, no. 2, pp. 154–171, Sep. 2013.
- [5] C. Farabet, C. Couprie, L. Najman, and Y. LeCun, "Learning hierarchical features for scene labeling," IEEE Trans. Pattern Anal. Mach. Intell., vol. 35, no. 8, pp. 1915–1929, Aug. 2013.
- [6] X. Chen, S. Xiang, C.-L. Liu, and C.-H. Pan, "Aircraft detection by deep belief nets," in Proc. IAPR Asian ACPR, 2013, pp. 54–58.
- [7] G. Liu, X. Sun, K. Fu, and H. Wang, "Aircraft recognition in highresolution satellite images using coarse-to-fine shape prior," IEEE Geosci.Remote Sens. Lett., vol. 10, no. 3, pp. 573–577, May 2013.
- [8] Sun, Hao, et al. "Automatic target detection in high-resolution remote sensing images using spatial sparse coding bag-of-words model." IEEE Geoscience and Remote Sensing Letters 9.1 (2012): 109-113.
- [9] Hinton, Geoffrey E. "A practical guide to training restricted boltzmann machines." Neural Networks: Tricks of the Trade. Springer Berlin Heidelberg, 2012. 599-619.
- [10] M.-M. Cheng, G.-X. Zhang, N. J.Mitra, X. Huang, and S.-M. Hu, "Global contrast based salient region detection," in Proc. IEEE CVPR, 2011, pp. 409–416.
- [11] 2013M. Ranzato, J. Susskind, V. Mnih, and G. E. Hinton, "On deep generative models with applications to recognition," in Proc. IEEE CVPR, 2011, pp. 2857–2864.
- [12.] X. Sun, H. Wang, and K. Fu, "Automatic detection of geospatial objects using taxonomic semantics," IEEE Geosci. Remote Sens. Lett., vol. 7, no. 1, pp. 23–27, Jan. 2010
- [13] Y. Bengio, P. Lamblin, D. Popovici, and H. Larochelle, "Greedy layerwise training of deep networks," in Proc. NIPS, 2006, pp. 153–160.
- [14] Hinton, S. Osindero , and Y.-W. Teh, "A fast learning algorithm for deep belief nets," Neural Comput., vol. 18, no. 7, pp. 1527–1554, Jul. 2006.

# IJEAST

INTERNATIONAL JOURNAL  
OF ENGINEERING APPLIED SCIENCE  
AND TECHNOLOGY

## ABOUT IJEAST

International Journal of Engineering Applied Science and Technology (IJEAST) is a peer-reviewed, open access journal that publishes high-quality research papers in the field of Engineering, Applied Science and Technology.

IJEAST aims to provide a platform for researchers, academicians, and professionals to share their innovative ideas, research findings, and practical experiences with the global scientific community.

## FOCUS AREAS

- Engineering
- Applied Science
- Technology
- Innovation & Development
- Interdisciplinary Studies



### PEER REVIEWED

All submissions are rigorously peer reviewed to ensure quality.



### OPEN ACCESS

Free and unrestricted access to research for all.



### GLOBAL REACH

Connecting researchers and professionals worldwide.



### TIMELY PUBLICATION

We ensure a swift and efficient publication process.



For more information, visit our website  
[www.ijeast.com](http://www.ijeast.com)



INTERNATIONAL JOURNAL  
OF ENGINEERING APPLIED SCIENCE  
AND TECHNOLOGY

✉ [editor@ijeast.com](mailto:editor@ijeast.com)

🌐 [www.ijeast.com](http://www.ijeast.com)

📍 India



2455-2143