



IJEAST

INTERNATIONAL JOURNAL
OF ENGINEERING APPLIED SCIENCE
AND TECHNOLOGY



VOLUME : 4 ISSUE : 12 Print / Issue Publication Date: 10-Jun-2020



ISSN : 2455-2143



DOI : 10.33564/IJEAST.2020.v04i12.084

Indexed In



WWW.IJEAST.COM

editor@ijeast.com

CONTROL OF THREE PORT DC-DC CONVERTER FOR QUASI Z SOURCE INVERTER BASED GRID CONNECTED PV-BATTERY APPLICATION

S.C. Vijayakumar
Asst. Professor,
EEE department,
Vel Tech, Avadi, Chennai, India

K. Jayasurya
U.G. Scholar
EEE department
Vel Tech, Avadi, Chennai, India

G. Nishanth
U.G. Scholar,
EEE department,
Vel Tech, Avadi, Chennai, India

U. Saranraj
U.G. Scholar
EEE department
Vel Tech, Avadi, Chennai, India

Abstract— A control strategy for an energy management system (EMS) of a household nano-grid is presented in this paper. The proposed EMS is based on a state diagram. A three port converter (TPC) with direct storage capability is chosen and the states together with the state transitions are defined. The state diagram signals to two algorithms of which one calculates the battery current reference and the other allows the photovoltaic (PV) system to operate at the maximum power point (MPP) at all times. An extensive model has been implemented in MATLAB/Simulink using generic models to test the proposed control method.

Keywords— Three port converter, battery, control method, current, energy management system, maximum power point, photovoltaic.

I. INTRODUCTION

In the last years there is a growing interest in distributed generation systems (DGS) in the form of PV systems connected to households. Since the power generations of PV systems are dependent on the weather, a constant output power cannot be expected. The power generation reliability is playing a vital role for distribution companies and they therefore seek reliable power sources and consumers. By installing energy storage systems (ESS) in conjunction with PV systems, the shortcomings that power intermittency causes to the grid can be solved (Ding et al., 2014; Zeng et al., 2014; Zeng et al., 2015a; Zeng et al., 2015b). To regulate and accommodate the different voltage levels of PV modules and ESS, DC-DC converters have to be introduced into the systems. The general structure of such systems is depicted.

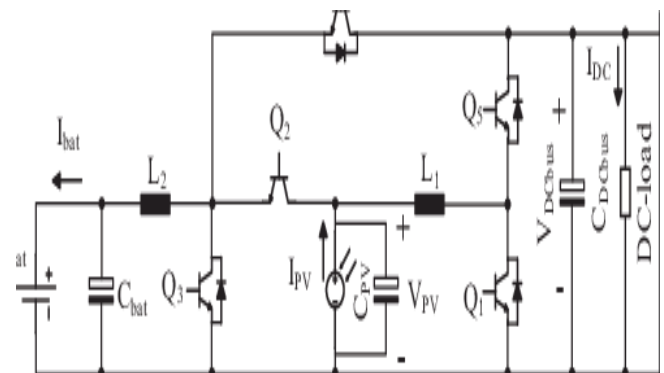

Fig.1. Three port Dc-Dc converter

II. EXISTING SYSTEM

- The existing system work focus on control system for EMS (Carosa et al., 2008).
- The TPC has direct storage capability, meaning that only one power conversion stage is needed between the PV system and the ESS, resulting in a more efficient converter and enabling a local EMS (Ouyang et al., 2012; Kumar et al., 2017; Kumar et al., 2017b).

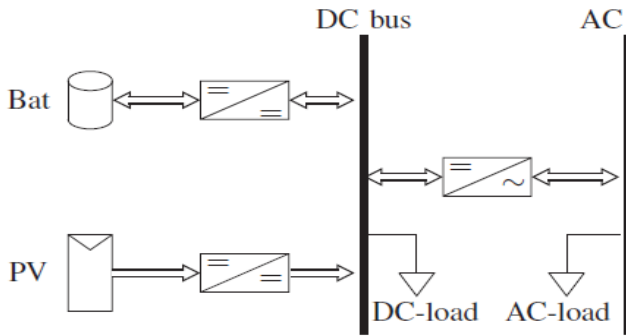

Fig.2. Three port Dc-Dc converter

III. ULTRASONIC SENSOR

The proposed system is a technically added quasi-Z-source inverter (qZSI) that is a new topology derived from the traditional Z-source inverter (ZSI) (Qian et al., 2010). The qZSI inherits all the advantages of the ZSI, which can realize buck/boost, inversion and power conditioning in a single stage with improved reliability. In addition, the proposed qZSI has the unique advantages of lower component ratings and constant dc current from the source. All of the boost control methods that have been developed for the ZSI can be used by the qZSI. The qZSI features a wide range of voltage gain which is suitable for applications in photovoltaic (PV) systems, due to the fact that the PV cell's output varies widely with temperature and solar irradiation. Theoretical analysis of voltage boost, control methods and a system design guide for the qZSI in PV systems are investigated in this paper. A prototype has been built in the laboratory. Both simulations and experiments are presented to verify the proposed concept and theoretical analysis.

IV. CONVERTER OPERATIONS

The circuit topology of the TPC is mention. The TPC is connected to the electrical grid through an H-Bridge single-phase inverter and a LCL filter (Sanchis et al., 2011; Shenai et al., 2001; Zhao et al., 2008). The ESS used in this work is a lithium-ion battery. The TPC can be described with simple buck and boost converters depending on the active switches. A short summary of the different operation modes is given below,

Converter Operation Modes

State Operation Active switches Bodydiode

- 0 (Idle) No operation None
- 1 Boost(PV ->DCBus) Q1 Q5
- 2 Buck(PV ->Bat) Q2 Q3
- 3 Boost(PV ->DCBus) & Buck(PV ->Bat) Q1,Q2 Q5,Q3
- 4 Boost(Bat ->DCBus) Q3 Q4
- 5 Boost(Bat ->DCBus) & Boost(PV ->DCBus) Q1,Q3 Q5,Q4
- 6 Buck(DCBus ->Bat) Q4 Q3
- 7 Buck(PV ->Bat) & Buck(DCBus ->PV) Q5,Q2 Q1,Q3

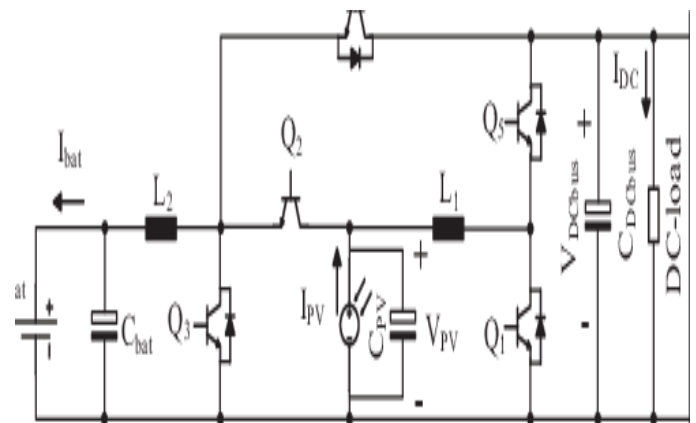

Fig.3. Proposed converter operating mode

V. CIRCUIT DIAGRAM AND WORKING

It is developed by Z source inverter system in the DC-DC converter system. The control of the whole system previously described, can be divided in two levels defined as top-level and bottom-level.

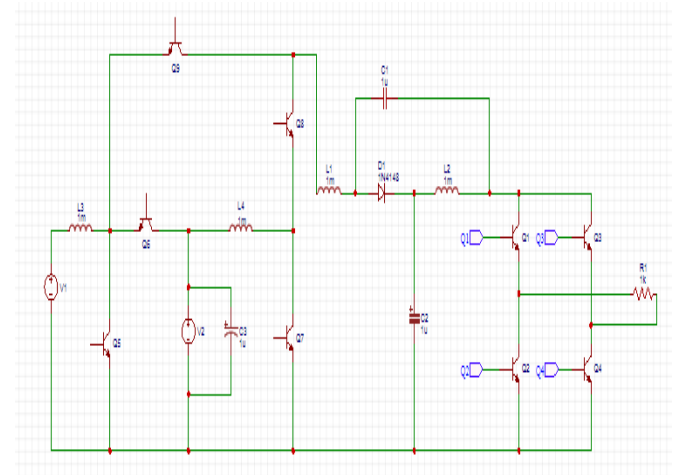

Fig.4. Circuit diagram of Z source inverter in DC-DC converter system.

The top-level refers to the energy management system (EMS), which controls the power flow in order to make efficient use of the power produced and reduce the power consumed from the electrical grid. In addition, the EMS has to ensure that the PV system always operates at the maximum power and that the ESS power flow is carefully controlled to prolong its lifetime. The bottom-level refers to the regulation of the DC-DC converters from the references provided by the EMS.

VI. SIMULATION DIAGRAM

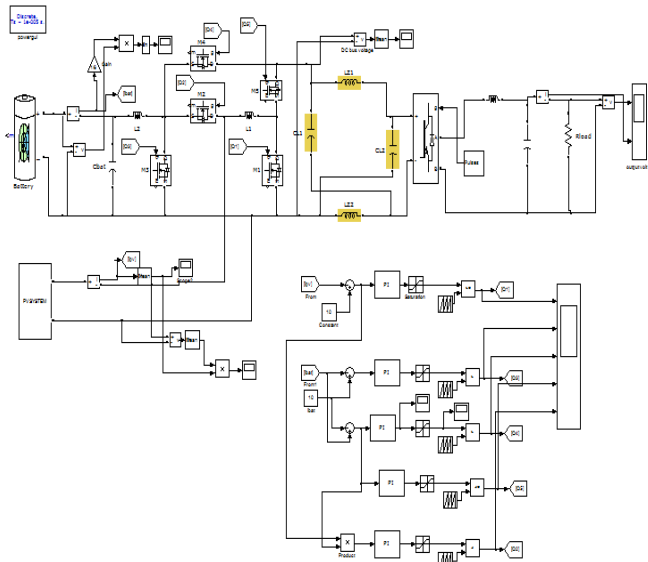

Fig.5. Simulation diagram of proposed system

VII. SIMULATION RESULT

Figures 6, 7 and 8 show the wave form of PV power, battery power, and DC bus voltage. The Output Voltage and Current waveform is shown in figure 9.

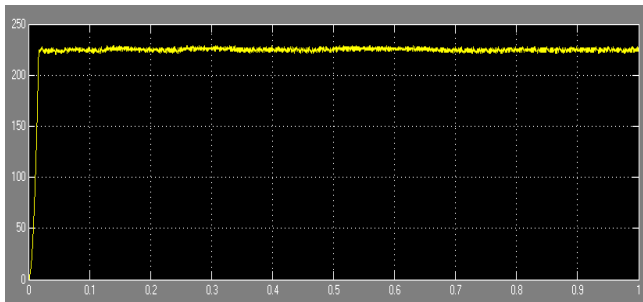

Fig.6. PV power

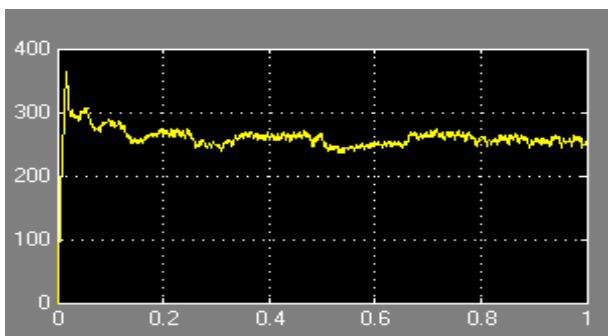

Fig.7. battery power

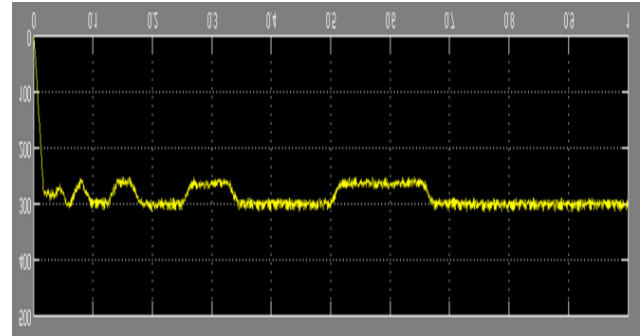

Fig.8. DC bus voltage

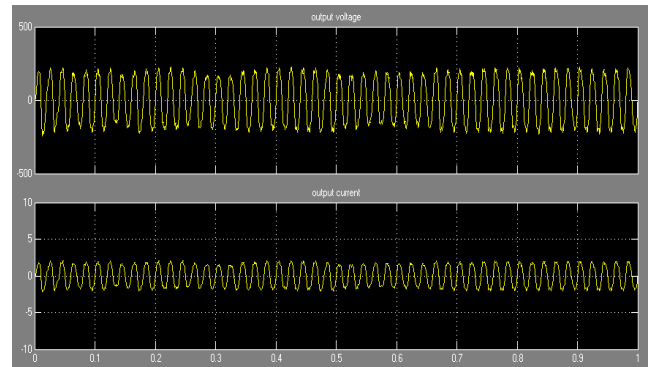

Fig.9. Output Voltage and Current

VIII. CONCLUSION

It has been demonstrated that the proposed TPC can be controlled with a state diagram. The TPC's operating modes were identified as the states and numerous transition condition were implemented. Besides the state diagram, a battery algorithm and a MPPT comprises the EMS of the proposed TPC. Testing the proposed EMS in MATLAB/Simulink yielded results which show that the EMS is able to follow the demand specified by a grid operator. The response of the system with respect to the grid is faster than 500ms. In addition transients due to transitions between states can be minimized by use of the battery algorithm. Future work would be to include more

IX. REFERENCE

[1] Ding,Z., Yang,C., Zhang,Z., Wang,C. and Xie,S (2014).A Novel Soft-Switching Multiport Bidirectional DC–DC Converter for Hybrid Energy Storage System IEEE Transactions on Power Electronics, 29(4), 1595-1609.

[2] Zeng,J., Qiao,W., Qu,L. and Jiao,Y.(2014)An Isolated Multiport DC–DC Converter for Simultaneous Power Management of Multiple Different Renewable Energy Sources IEEE Journal



of Emerging and Selected Topics in Power Electronics., 2, 70-78.

- [3] Zeng,J., Qu,L. and Qiao,W.(2015a).LCL-resonant single-switch isolated DC–DC converter IET Power Electronics., 8, 1209-1216.
- [4] Zeng,J.,Qiao,W., and Qu,L.(2015) An Isolated Three-Port Bidirectional DC–DC Converter for Photovoltaic Systems With Energy Storage IEEE Transactions on Industry Applications 51, 3493-3503.
- [5] Carosa,T., Zane,R., and Maksimovic,D.(2008) Scalable Digital Multiphase Modulator IEEE Transactions on Power Electronics. 23., 2201-2205.
- [6] Ouyang, Z.,Zhang,Z., Andersen,M. and Thomsen,O.(2012).Four Quadrants Integrated Transformers for Dual-Input Isolated DC–DC Converters IEEE Transactions on Power Electronics, 27, 2697-2702..
- [7] Kumar,D., Zare,F. and Ghosh,A.(2017)DC Microgrid Technology: System Architectures, AC Grid Interfaces, Grounding Schemes, Power Quality, Communication Networks, Applications, and Standardizations Aspects IEEE Access 5, 12230-12256.
- [8] Kumar,D., Zare,F., and Ghosh,A.(2017) DC Microgrid Technology: System Architectures, AC Grid Interfaces, Grounding Schemes, Power Quality, Communication Networks, Applications, and Standardizations Aspects IEEE Access., 5, 12230-12256..
- [9] Qian,Z., Abdel-Rahman,O. and Batarseh,I.(2010) An Integrated Four-Port DC/DC Converter for Renewable Energy Applications IEEE Transactions on Power Electronics, 25, 1877-1887.,
- [10] Sanchis,E. et al.,(2011) Bidirectional High-Efficiency Nonisolated Step-Up Battery Regulator IEEE Transactions on Aerospace and Electronic Systems., 47., 2230-2239.
- [11] Shenai,K., Neudeck,P., and Schwarze, G.,(2001)Design and technology of compact high-power converters IEEE Aerospace and Electronic Systems Magazine, 16, 27-31.
- [12] Zhao,C., Round,S. and Kolar,J.(2008) An Isolated Three-Port Bidirectional DC-DC Converter With Decoupled Power Flow Management IEEE Transactions on Power Electronics., 23, 2443-2453.

IJEAST

INTERNATIONAL JOURNAL
OF ENGINEERING APPLIED SCIENCE
AND TECHNOLOGY

ABOUT IJEAST

International Journal of Engineering Applied Science and Technology (IJEAST) is a peer-reviewed, open access journal that publishes high-quality research papers in the field of Engineering, Applied Science and Technology.

IJEAST aims to provide a platform for researchers, academicians, and professionals to share their innovative ideas, research findings, and practical experiences with the global scientific community.

FOCUS AREAS

- Engineering
- Applied Science
- Technology
- Innovation & Development
- Interdisciplinary Studies



PEER REVIEWED

All submissions are rigorously peer reviewed to ensure quality.



OPEN ACCESS

Free and unrestricted access to research for all.



GLOBAL REACH

Connecting researchers and professionals worldwide.



TIMELY PUBLICATION

We ensure a swift and efficient publication process.



For more information, visit our website
www.ijeast.com



INTERNATIONAL JOURNAL
OF ENGINEERING APPLIED SCIENCE
AND TECHNOLOGY

✉ editor@ijeast.com

🌐 www.ijeast.com

📍 India



2455-2143