



IJEAST

INTERNATIONAL JOURNAL
OF ENGINEERING APPLIED SCIENCE
AND TECHNOLOGY



VOLUME : 6 ISSUE : 7 Print / Issue Publication Date: 25-Feb-2022



ISSN : 2455-2143



DOI : 10.33564/IJEAST.2021.v06i07.009

Indexed In



WWW.IJEAST.COM

editor@ijeast.com

SMALL FLOATING HYDROELECTRIC POWER PLANT

Ricardo Roberto Lembo
 Physicist - Independent researcher
 Ciudad Autónoma de Buenos Aires
 Argentina

Abstract- The operation of a surface hydroelectric power plant made up with paddles that articulate with one another to form a close chain is analyzed. This chain is partially submerged in a stream of water in such a way that the drag force of the stream causes its movement. The extractable power is theoretically calculated according to the stream speed and to the number of submerged paddles. A prototype of a paddle chain is designed and built in order to carry out measurements.

Keywords- Renewable energy, hydroelectric plant

Suppose you have a stream of water in a laminar flow with velocity V in the course of which a floating paddle chain is anchored with N submerged and moving paddles driven by the stream of water with velocity v relative to the shore, as it is shown in Figure 1, so that the relative velocity of the paddle chain with respect to the stream is $u = V - v$.

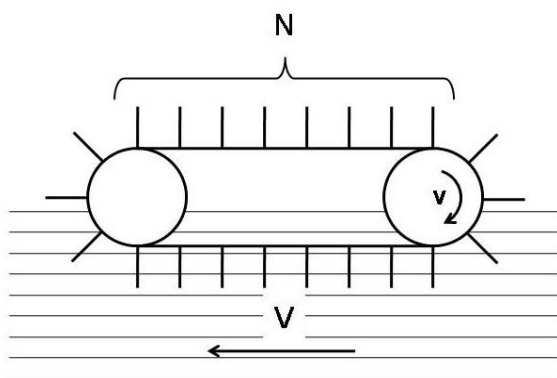

Figure 1

We will consider that the surface facing the stream of each paddle is A , being d the separation distance between two consecutive paddles, although we will not take into account quantitatively the effects of that separation, which will be studied experimentally later.

If P represents the real obtainable power, P_S the nominal output power when considering only the N submerged paddles, P_0 the contribution from the paddles that are on the support wheels and enter or leave the water, while P_r represents the losses due to friction of the links of the paddles on the support wheels and of the axles of the same ones on their bearings, you will have that:

$$P = P_S(u, d, N) + P_0(u, d) - P_r \quad (1)$$

We will calculate the output rated power P_S and leave for the end a qualitative consideration about P_S and P_r . We will assume that the latter will remain constant.

If we assume that the separation distance d between paddles is not changed and that the velocity v of the paddle chain is the same for different values of N , then P_S will be the same and P_r will only depend on N for each value of v that is fixed.^S

It is also reasonable to assume that the expression obtained for P_S will converge to a linear function for values $N \gg 1$. Designating with ρ the density of the water we will call P_{e1} the mechanical power that reaches the first of the N submerged paddles, which we will identify from now on as a function K , dependent on the relative speed of the stream, that is:

$$P_{e1} = 1/2 \rho A u^2 v = K(u) \quad (2)$$

It is immediate to see that $K(v = V) = 0$ and also that $K(v = 0) = 0$, so that there is a value that maximizes the one of $K(v = 1/3 V)$, as indicated in Figure 2.

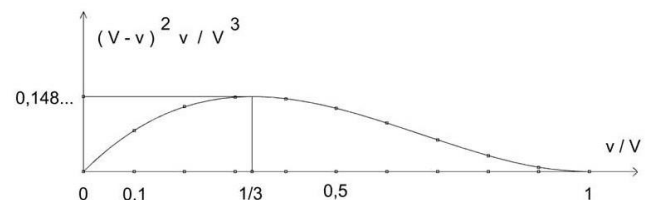

Figure 2

We will calculate the expression of P_S for some value of v that we will assume fixed.

Under such conditions the value of K expressed by (2) shall remain the same for all value of N , obtaining for the nominal output power P_{s1} of the first paddle the following value:

$$P_{s1} = K \eta \quad (3)$$

where η is an efficiency factor between 0 and 1. We will number the submerged paddles in increasing order and in the sense of the flow of the stream from 1 to N , as shown in Figure 3.

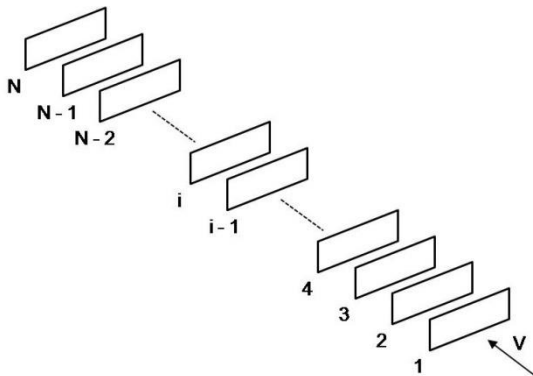

Figure 3

In order to calculate the general expression for the nominal mechanical power that is possible to extract from the paddle chain we will apply the above to the first paddle and then extend the result to the i -th paddle.

Figure 4 shows a qualitative representation of some streamlines in the space between two consecutive paddles according to the following description.

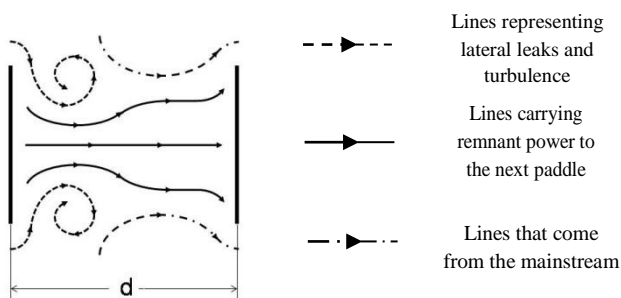

Figure 4

The mechanical power not extracted by the first paddle will be lost or returned to the stream of water and we will call it *remnant power* between paddles 1 and 2. Whereas (3) is given by:

$$P_{r1,2} = K (1 - \eta) \quad (4)$$

A fraction π of this power (corresponding to the one carried by the stream represented by dashed line in Fig. 4) will be lost due to lateral leaks and turbulence, while the rest (corresponding to the continuous lines in Fig. 4) will affect paddle 2, according to the following expression:

$$P_{e2} = P_{r1,2} (1 - \pi) \quad (5)$$

A fraction that comes from the mainstream (dotted and dashed lines in Fig. 3) must be added to this contribution, which we can write as:

$$P_{c1,2} = K \alpha \quad (\text{with } \alpha > 0) \quad (6)$$

From (4), (5) and (6) the following expression results for the output power of paddle 2 due to the fraction of the remaining power and the contribution of the mainstream:

$$P_{s2} = K \eta [(1 - \eta) (1 - \pi) + \alpha] \quad (7)$$

Presumably the coefficients π and α will be dependent on the separation distance d between paddles, which as we have said we will not take into account quantitatively in this model, while η must be mainly related with the geometry of the paddles.

Next we will deduce the expression corresponding to the output power of the i -th paddle to finally calculate the total nominal output power of the set of N paddles, with the hypothesis that the different coefficients will maintain their same values when moving from one paddle to the next.

Considering the first pair of paddles ($i = 1$) we have the scheme represented in Figure 5 that balances the partial powers involved.

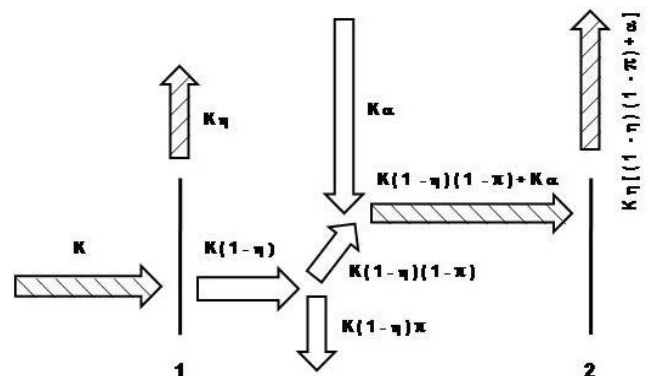

Figure 5

For reasons of brevity we will define:

$$F = (1 - \eta) (1 - \pi) \quad (8)$$



$K \eta$ being the output power of the first paddle the expression (7) results in the following form:

$$P_{s_2} = K \eta (F + \alpha)$$

Continuing with the calculation procedure, the following sequence of output powers of the successive paddles can be completed:

$$P_{s_1} = K \eta$$

$$P_{s_2} = K \eta (F + \alpha)$$

$$P_{s_3} = K \eta (F^2 + \alpha F + \alpha)$$

Finally we obtain the following result for the i-th paddle:

$$P_{s_i} = K \eta [(1 - \alpha) F^{i-1} + \alpha \sum_{j=1}^i F^{j-1}]$$

and the total rated power output will be obtained by calculating:

$$P_s = \sum_{i=1}^N P_{s_i}$$

resulting in the following expressions:

$$P_s = K \eta [(1 - \alpha) \sum_{i=1}^N F^{i-1} + \alpha \sum_{i=1}^N \sum_{j=1}^i F^{j-1}] =$$

$$= K \eta [(1 - \alpha) \sum_{i=1}^N F^{i-1} + \alpha \sum_{i=1}^N \frac{1 - F^i}{1 - F}]$$

Finally the following result is obtained for the total rated output power from the paddle chain:

$$P_s = \frac{K \eta}{1 - F} [N \alpha + (1 - \frac{\alpha}{1 - F}) (1 - F^N)] \quad (9)$$

Taking into account the expression (F1), the real obtainable power will be given by:

$$P(N) = \frac{K \eta}{1 - F} [N \alpha + (1 - \frac{\alpha}{1 - F}) (1 - F^N)] + P_o - P_r \quad (10)$$

We will define $\lambda (N)$ as the actual obtainable power per unit of input power to the first paddle, i.e.:

$$\lambda (N) = P (N) / K$$

from which the expression (10) leads to:

$$\lambda (N) = \frac{\alpha \eta}{1 - F} N + \frac{\eta}{1 - F} (1 - \frac{\alpha}{1 - F}) (1 - F^N) + \frac{P_o - P_r}{K} \quad (11)$$

Disregarding for $N \gg 1$ the term in F^N , being that $F < 1$, we obtain the following linear approximation for the actual output power per unit of input power:

$$\lambda^* (N) \approx \frac{\alpha \eta}{1 - F} N + \frac{\eta}{1 - F} (1 - \frac{\alpha}{1 - F}) + \frac{P_o - P_r}{K} \quad (12)$$

that is, from (11) and (12) it can be written:

$$\left\{ \begin{aligned} \lambda (N) &= a N + b - \frac{\eta}{1 - F} (1 - \frac{\alpha}{1 - F}) F^N + \frac{P_o - P_r}{K} \quad (13) \\ \lambda^* (N) &\approx a N + b + \frac{P_o - P_r}{K} \quad (14) \end{aligned} \right.$$

being:

$$a = \frac{\alpha \eta}{1 - F} \quad (15)$$

$$b = \frac{\eta}{1 - F} (1 - \frac{\alpha}{1 - F}) \quad (16)$$

Curves similar to those represented qualitatively in Figure 6 can be drawn from experimental determinations of the actual obtainable output power per unit of input power for different values of N , and taking into account (12) and (14) it has been defined:

$$B = b + \frac{P^o - P^r}{K}$$

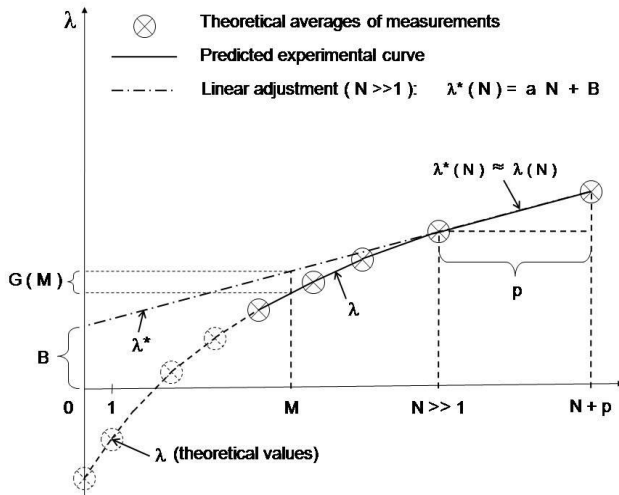

Figure 6

Obviously, values of λ may be determined experimentally only while the paddle chain is in motion, i.e. provided that $\lambda(N) > 0$ is met.

It has been suggested in Figure 6 that this condition is not met by representing negative values of power for small values of N , that is, having assumed that the power obtainable from a few paddles was not sufficient to overcome friction.

The value of F can be obtained as follows from defining:

$$G(M) = \lambda^*(M) - \lambda(M)$$

and taking into account (13) and (14) it results:

$$G(M) = \frac{\eta}{1-F} \left(1 - \frac{\alpha}{1-F}\right) F^M$$

$$G(M+p) = \frac{\eta}{1-F} \left(1 - \frac{\alpha}{1-F}\right) F^{M+p}$$

whence:

$$F^p = \frac{G(M+p)}{G(M)} \quad (17)$$

Also, for $M=0$:

$$F^p = \frac{G(p)}{G(0)} \quad (18)$$

and from (17) in general results for every value of i :

$$G(i+1)$$

$$F = \frac{G(i)}{G(i+1)}$$

Since from (13) and (14) it is:

$$G(0) = \lambda^*(0) - \lambda(0) = b$$

Taking into account (18) the result is:

$$\lambda^*(0) - \lambda(0) = \frac{G(p)}{F^p}$$

from where:

$$\lambda(0) = \lambda^*(0) - \frac{G(p)}{F^p} \quad (19)$$

From Figure 6 we have that:

$$\lambda^*(0) = B = [\lambda^*(N) - aN]_{N \gg 1}$$

and taking into account (19) it turns out the following:

$$\lambda(0) = [\lambda^*(N) - aN]_{N \gg 1} - \frac{G(p)}{F^p} \quad (20)$$

expression that must converge to the actual removable power of a water wheel, that is, when the paddle chain does not have any submerged paddles in the linear section ($N=0$) and only those ones of the support wheels are considered.

On the other hand, from (15) and (16) you have that:

$$\frac{b}{a} = \frac{1}{\alpha} - \frac{1}{1-F}$$

from where:

$$\alpha = \frac{1-F}{1 + \frac{b}{a}(1-F)} \quad (21)$$

From (15) you have that:

$$\eta = \frac{a(1-F)}{\alpha}$$



and taking into account (21) we obtain:

$$\eta = a + b (1 - F) \quad (22)$$

From the definition (8) we have that:

$$\pi = 1 - \frac{F}{1 - \eta}$$

and taking into account (22) the result is:

$$\pi = 1 - \frac{F}{1 - [a + b (1 - F)]} \quad (23)$$

Considerations regarding the shape and separation distance between paddles

The expressions (20), (21), (22) and (23) allow us to characterize the design of the paddle chain in order to improve the general operation.

Changes in the shape of the paddles will mainly affect the value of the parameter η , while the effect of varying the separation d between paddles should be mainly the variation in the value of the parameters α and π .

With regard to the separation d between paddles, two extreme cases may be distinguished:

1er case: $d \rightarrow 0$

If the separation distance d between paddles were very small compared with the linear dimensions it is reasonable to think that the device will have to behave as if there were only a single paddle. That is, there should be no significant contributions from the adjacent water stream ($\alpha \rightarrow 0$) since there would not be enough space to enter.

Starting from the expression (11) we will have for $\alpha \rightarrow 0$:

$$\lambda \rightarrow \frac{\eta}{1 - F} (1 - F^N) + \frac{P_o - P_r}{K}$$

Recalling that for $d \rightarrow 0$ the power that has not been extracted by the first paddle must be mostly returned to the stream ($\pi \rightarrow 1$), since there will be no fraction of it capable of entering practically into non-existing spaces between paddles, it will result in $F \rightarrow 0$, from where:

$$\lambda \rightarrow \eta + \frac{P_o - P_r}{K}$$

result that corresponds to the removable power per unit of input power for a single paddle and which indicates the

possibility that it results in $\lambda \rightarrow 0$, i.e. that the paddle chain cannot be moved by the current due to an excessive friction.

2nd case: $d \rightarrow \infty$

In the case that the separation distance between paddles is very large compared to the extinction range of the turbulence, it is reasonable to assume that $\alpha \rightarrow 1$ since it will facilitate the entry of water from the mainstream, which is equivalent to interpreting that each paddle will tend to be seen as independent of the others.

At the same time, because there will be no remaining power capable of reaching the next paddle (i.e. $\pi \rightarrow 1$), we will then have $F \rightarrow 0$, resulting that:

$$\lambda \rightarrow \eta [1 + (N - 1) \alpha] + \frac{P_o - P_r}{K}$$

expression that indicates that while the first paddle will allow to extract power from the stream the remaining ones will only capture power from the adjacent stream as well as indicates that there will be a minimum value for N from which the paddle chain can move without being stopped by friction.

In the case that α approaches to the unit the power must increase linearly with the number of paddles, that is:

$$\lambda \rightarrow N \eta + \frac{P_o - P_r}{K}$$

Experimental prototype

In order to simplify the construction and economize in tooling, small dimensions will be adopted for the paddles, of the order of a few centimeters, and due to the quantity required for experimentation, two injection molds will be built for the manufacture of these parts with injected polypropylene.

Figure 7 shows the outlines of a prototype that includes a pair of side floats and a stream accelerator channel located below the submerged paddles. However, the prototype to be tested will be simplified in the less relevant aspects, such as the accelerator channel and the generator.

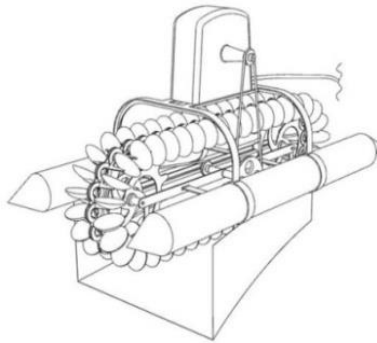

Figure 7

Each paddle shall consist on one or more surfaces (see Figure 8) installed in appropriate links that shall be articulated with each other. A bayonet-type crimp between the different links will allow their relative rotation within a small angle when reaching the wheels that hold the paddle chain. However, this angle will be limited in order to avoid the possibility of spontaneous disassembly of the whole.

The power-collecting surfaces, represented in Figures 7 and 8 by concave discs, will be removable in order to study the effect of changes in shape and size. For simplicity the study will start with flat discs.

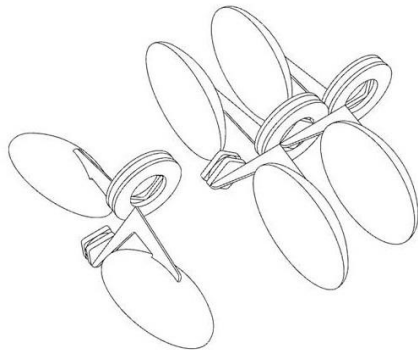

Figure 8

The separation between links may be varied in a discrete way, by inserting links without collecting surfaces, in order to be able to study the effects of the distance between paddles.

Preliminary calculations

The minimum distance between links shall be chosen in $d = 30 \text{ mm}$ and we shall assume a relative velocity of the flow regarding the one of the paddle chain $u = V - v$ of 1 m/s . We will choose for the power-collecting surfaces of each link plastic discs with 56 mm in diameter, resulting in:

$$A = 1/2 \times \pi \times 5,6^2 \times 10^{-4} \text{ m}^2 = 49,3 \text{ cm}^2$$

$$K = 1/2 \times 10^3 \times 49,3 \times 10^{-4} \text{ W} = 2,46 \text{ W}$$

Recalling the expression (9) for the total rated power, i.e.:

$$P = \frac{K \eta}{1 - F} \left[N \alpha + \left(1 - \frac{\alpha}{1 - F} \right) (1 - F^N) \right]$$

Table I is obtained, in which arbitrary but reasonable values have been chosen for the various parameters of the formula that gives the power.

The linear approximation has been used for the calculation of the power and a lower error of the order of $0,33 \%$ has been accepted when considering terms with $N > 4$.

Table I

u (m/s)	η	π	α	F	P (W)
1	0,4	0,6	0,4	0,24	$0,52 N + 0,61$

Arbitrary values

It is observed that for $N = 30$ the calculated value of obtainable rated power, that is, disregarding the friction losses and the contribution of the paddles on the support wheels, would be of the order of 16 W , i.e. an easily measurable value.

Injection molds

In the next column and page there are photographs of the injection molds for the manufacture with polypropylene of the collecting discs and the links of the paddle chain of a first prototype, a photograph of one link with its discs installed, a paddle chain with one meter in length showing only its links and the first prototype finished with its side floats.



1 meter in length paddle chain made with 72 polypropylene links without their collecting discs ($N = 30$)



Photographs of the injection molds of the collecting discs and the links



1 meter in length prototype with 72 polypropylene links and their discs and side floats ($N = 30$)



Link with its polypropylene collecting discs

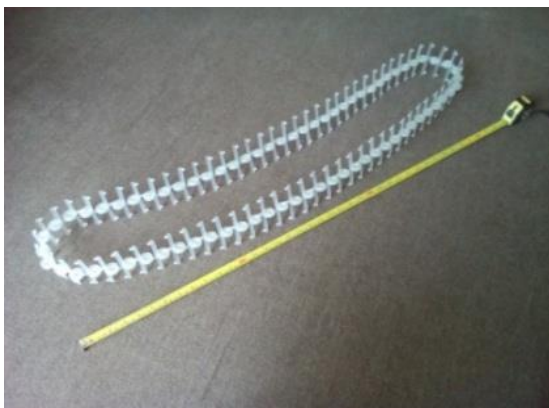

Conclusions

Assuming that the number of paddles on the support wheels is much less than N it is reasonable to accept that $P_o \ll P$, in which case it can be disregarded.

Also, taking into account that the previous tests carried out in a pool indicated that the movement of the paddle chain of the first prototype is very smooth starting from the rest, which would show a small value of static friction, it is also acceptable to assume that it will be possible to disregard P_o when compared with P .

At first prototype (see the photograph in the middle of this column) was towed in a swimming pool and it could be observed that when it is stopped from propelling and is left adrift the paddle chain stops, as expected because the relative velocity to the one of the water becomes zero ($K = 0$).

Also, as we mentioned in the previous section, it was seen that the movement of the paddle chain continuously accompanies the one of the frame in the water, which indicates very small losses (the movement does not occur by jumps, as it should be if it obeyed a significant static friction) as well as a good coupling between the paddles of the chain and the water.

Figure 9 shows a larger prototype and an electric generator that are currently being built to evaluate the various parameters defined in the course of this paper and some possible shapes for the paddles in order to improve the design.

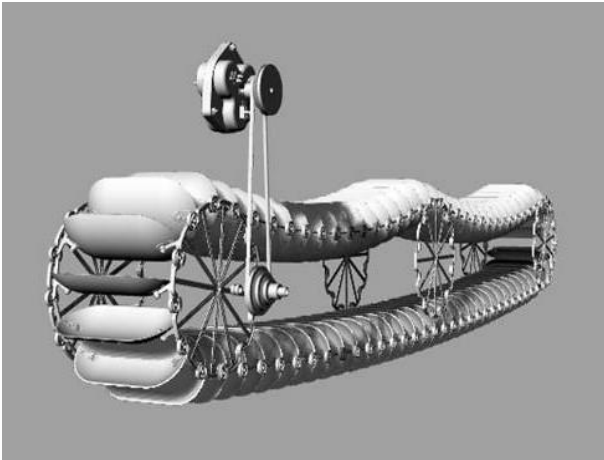

Figure 9

It should be noted that the limit for the number of paddles of the chain is imposed by the tensile effort that the links can withstand. Although this limitation will prevent excessively increasing the length, in order to obtain greater powers it will be possible generally to install several floating structures in parallel taking advantage of the ease of installation.

References

White, L. (1962), *Medieval Technology and Social Change*, Oxford Clarendon Press.

Csandy, G. T. (1964). *Theory of Turbomachines*, McGraw-Hill, London.

Matajx, C. (1972). *Mecánica de Fluidos y Máquinas Hidráulicas*, Harper & Row Publishers Inc. Ed. Harla, S.A. México.

NASA SP 290 (1972). *Turbine Design and Applications*.

Scholz, N. (1977). *Aerodynamics of Cascades*, AGARDograph 220.

Álvarez Cardona, A. (1985). La rueda hidráulica, *Revista Facultad Nacional de Agronomía*, vol. XXXVIII, N° 2, Universidad Nacional de Colombia, Medellín, Colombia, (26 p).

Raghunathan, S. (1995). The Wells Air Turbine for Wave Energy Conversion, Department of Aeronautical Engineering, Queens's University, Belfast, U.K., (pp. 335 – 386).

Oleson, J. P. (2000). Water-Lifting, in Wikander, Örjan, *Handbook of Ancient Water Technology, Technology and Change in History*, 2, Leiden, (pp. 217–302).

Quispe, F. M. (2005). *Diseño de una turbina de río para la generación de electricidad en el distrito de Mazán-Región Loreto*, Universidad Nacional Mayor de San Marcos, Lima, Perú, (74 p).

Darabi, A., Poriavali, P. (2007). Guide Vanes Effect of Wells Turbine on OWC Wave Power Plant Operation, *Proceedings of the World Congress on Engineering*, vol I, London, U.K., (5 p).

Franco, J., Fasoli, H. (2008). Conference, *Primeras Jornadas de Energía*, Facultad Regional Paraná, Universidad Tecnológica Nacional, Paraná (Entre Ríos), Argentina, (6 p).

Izquierdo, L., Eisman, J. (2008). La electrificación sostenible de zonas rurales aisladas de países en desarrollo mediante microsistemas eléctricos renovables, *Lecture, XV Simposio Solar Peruano*, Cajamarca, Perú, (pp. 83 – 92).

Al Dbiyat, M. (2009). Les norias de Hama sur l'Oronte, un système traditionnel de l'utilisation de l'eau fluviale, *Gestion durable et équitable de l'eau douce en Méditerranée, mémoire et traditions, avenir et solutions*, Conference Proceedings from Cinquièmes Rencontres Internationales Monaco et la Méditerranée, Monaco, (pp. 196-197).

Maché, C., Stivanello, J., Jacobi, D., Gareis, G. (2009). Obtención de Hidrógeno mediante Turbinas de Llanura, Facultad Regional Paraná, Universidad Tecnológica Nacional, Paraná (Entre Ríos), Argentina, (5 p).

Santa, A., Lozano, M., Pinilla, A. E. (2009). Generación de energía eléctrica con turbinas Wells, *Universidad de los Andes*, Colombia, (pp. 56 – 64).

Grünwald, A. R. (2012). Estudio de la generación energética con turbinas hidráulicas en las corrientes marinas, *Universidad Politécnica de Cartagena*, Colombia, (104 p).

Baselt, I. and Malcherek, A., Maerker, C. (2013). Steffturbine - A micro hydro turbine based on conveyor belt technology, Conference, *Water Storage and Hydropower Development for Africa*, Addis Abeba, (pp. 2 – 8).

IJEAST

INTERNATIONAL JOURNAL
OF ENGINEERING APPLIED SCIENCE
AND TECHNOLOGY

ABOUT IJEAST

International Journal of Engineering Applied Science and Technology (IJEAST) is a peer-reviewed, open access journal that publishes high-quality research papers in the field of Engineering, Applied Science and Technology.

IJEAST aims to provide a platform for researchers, academicians, and professionals to share their innovative ideas, research findings, and practical experiences with the global scientific community.

FOCUS AREAS

- Engineering
- Applied Science
- Technology
- Innovation & Development
- Interdisciplinary Studies



PEER REVIEWED

All submissions are rigorously peer reviewed to ensure quality.



OPEN ACCESS

Free and unrestricted access to research for all.



GLOBAL REACH

Connecting researchers and professionals worldwide.



TIMELY PUBLICATION

We ensure a swift and efficient publication process.



For more information, visit our website

www.ijeast.com



INTERNATIONAL JOURNAL
OF ENGINEERING APPLIED SCIENCE
AND TECHNOLOGY

✉ editor@ijeast.com

🌐 www.ijeast.com

📍 India



2455-2143