



# IJEAST

INTERNATIONAL JOURNAL  
OF ENGINEERING APPLIED SCIENCE  
AND TECHNOLOGY



**VOLUME : 1    ISSUE : 12    Print / Issue Publication Date: 30-Nov-2016**



**ISSN : 2455-2143**



Indexed In



[WWW.IJEAST.COM](http://WWW.IJEAST.COM)

[editor@ijeast.com](mailto:editor@ijeast.com)



# INTRODUCE AUTOMATION ENGINEERING ON RAILWAYS: IMPLEMENTATIONS IN GREEK NETWORKS

E. Kalathas  
Dept. of Automation  
Engineering  
Piraeus University of  
Applied Sciences, Athens,  
Greece

M. Papoutsidakis  
Dept. of Automation  
Engineering  
Piraeus University of Applied  
Sciences, Athens, Greece

D. Tseles  
Dept. of Automation  
Engineering  
Piraeus University of  
Applied Sciences,  
Athens, Greece

**Abstract**— In the first railways in 1830s and 1840s there wasn't any system to inform the driver about the condition of the track, so accidents happened. In order to achieve the most important goal of safety, we had to invent methods of controlling the movement of trains. This system uses circuits on the track which are short-circuited by wheels and axles of a wheel, setting the indication of danger "red" in signalling lamp, behind the train, in order to have adequate time headway between trains to avoid collision of a train with the one in front. The main disadvantage of this system, which is entirely dependent on the driver's perception, led to the development of the application with the term Automatic Protection Trains (A.T.P.), to provide continuous control of train speed. The A.T.P. is a control system used by the railways to avoid collisions with the aid of automatic motion control of maximum speed and braking of the train. This paper presents the equipment of A.T.P. located in each vehicle equipped with a driving cab to describe the automatic functions for the continuous and reliable monitoring of speed and braking. The desired and actual speed indication in the cab, the audible alarm on exceeding the desired speed and the automatic activation of the braking process of the train as well as the stop at stop signs. Along we examine the auxiliary systems in railway track used for the support. In this work we highlight the innovative process that exists in the L.S.A.P trains with the adaptation of the old technology trains (8th, 10th pick). We compare with the previous signalling system (IDUZI) and explain how the A.T.P. is used as a tool to prevent accidents by ensuring smaller time headway between trains to carry more passengers. Finally,

**the conclusions and future prospects for greater rail safety are presented.**

**Keywords**— *A.T.P (Automatic Train Protection), Cab Signalling, Functional analysis, Signal, Control units*

## I. INTRODUCTION

In the early 20th century, the wide spreading of cars and airplanes has transformed the transport sector. The rapid technical development of the car greatly restricted the use of the railway to a point that the feasibility of its conservation was discussed. However, over long distances and large quantities of goods, the railway proved irreplaceable. Nowadays, railways hold a leading position in the economy and complement the other transportation means. The railway transport is one of the cheapest methods for transporting goods with the exception of sea transport. Used especially in cases of large amounts of fuel or minerals (eg coal). The transport of goods by rail is practical and is especially common in Russia and in America, due to the extremely long distances in these countries [1].

Moreover, taking into account the rapid depletion of natural resources (oil and other hydrocarbons), today more than ever, the development of electric movement systems is imperative as electricity, apart from hydrocarbon combustion product can be produced from renewable energy sources (wind, solar, geothermal and soon fusion).



The implementation, planning and design of transport infrastructure and investment is a difficult task, either as integrated intervention or local optimization effort. The transfer from one region to another, with a minimum expenditure of time is the main profit from the use of the rail network. The support of the economies in their comparative advantages is a necessity, if not the only way. The railway transport infrastructure is part of the development field and follows the development of each region. Wherever there is developed public railway transportation, there is a strong economy activity in form of businesses, jobs, easy access to markets, trade development, convenient and fast movement of people and goods, tourism development. An underground railway network (metro) which moves in a tunnel under the city, does not produce exhaust gas, the production of electricity needed to move the subway has no environmental effects, no delays from traffic (traffic jams) and additionally can develop high speed, without risk of accidents. Also national economy saves millions from the metro operation annually, while the expansion in one area leads to an increase in real estate values.

In general, rail transport is a key to development. The accessibility of people at work, health, education and other social activities is essential to the welfare of people in rural and urban areas. With the development of the railway, there was the need to optimize the system in order to keep passengers and cargo safe. Thus a traffic system was developed based on the exclusion of sections or otherwise in length distances [2]. These systems, based on exclusion sections (block systems), prohibit the train from entering a line segment, until the previous train, already leaves this section. Each exclusion section (block) is protected by a stable signal, positioned at the entrance of the section and clearly visible to the driver of any approaching train. If the section is "clean", ie there is no train in it, the signal will provide an indication of "free". Conversely, if the section is occupied by train, the signal will provide the indication "Stop". The next train will be waiting at the entrance of the section, until the one ahead leaves. All signaling systems are designed and operated on the basis of this principle.

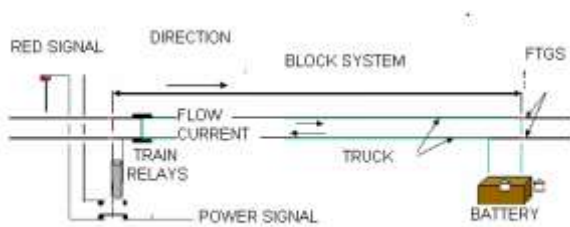

Fig. 1. Diagram of Automatic block system

On the basis of most modern railway signalling system is the automatic exclusion (automatic block system), which was first used in 1872 and is one of the early automation applications in industry. This system uses track circuits, which are short-circuited by the wheels and axles of a train, activating the indication of danger (red) on the signaling lamp behind the train (or the lamp in front of the train, in single track cases). The development of this application, generally known by the term ATP (Automatic Train Protection), continuously developed from the 1950s to provide continuous control of train speed. The Automatic Train Protection system is mainly applied in congested urban and suburban railways, and the high speed lines of advanced railway networks in Europe and Japan. In Train Protection Automatic system, visual indications to driver's cab reproduce the information of the signalling lights in the direction of train movement, or provide up to ten different directions, related to maintaining speed, acceleration or deceleration, compared with the situation of the railway line. The failure of the driver to respond to restrictive directive will automatically start braking and reducing delivered power. The indications in driver's cab activated by the on the train processing of coded signals, channeled either through the rails or by wire circuits adapted to the rails [3].

## II. DESCRIPTION OF ATP SYSTEM

### A. Description

Most modern ATP systems include braking characteristics (braking profile) of the train located in the driver's cab. Thereby checking whether the train is always within the restrictive speed limits as it approaches an occupied part, defined by the deceleration speed curve of the specific train. Microcomputer on the train receives indications of (a) the current speed, (b) the distance from the next signalized section (remaining distance), and (c) the speed limit in the next section (speed-target) and ensure continuously that current speed is at levels that allow the achievement of the target speed-before entering the next section. If the train violates speed limits curve, will cause automatic brake application.

The continuous transmission system ATP utilizes on track circuits or loops of wire between the tracks, (ATP on the line) to transmit information to the train as it moves. A pair of collecting wires hanging down from the front of the train (antennas, pulse code generators) record the flow of information and transfers it to the processors of the ATP system of the train in driver's cab.

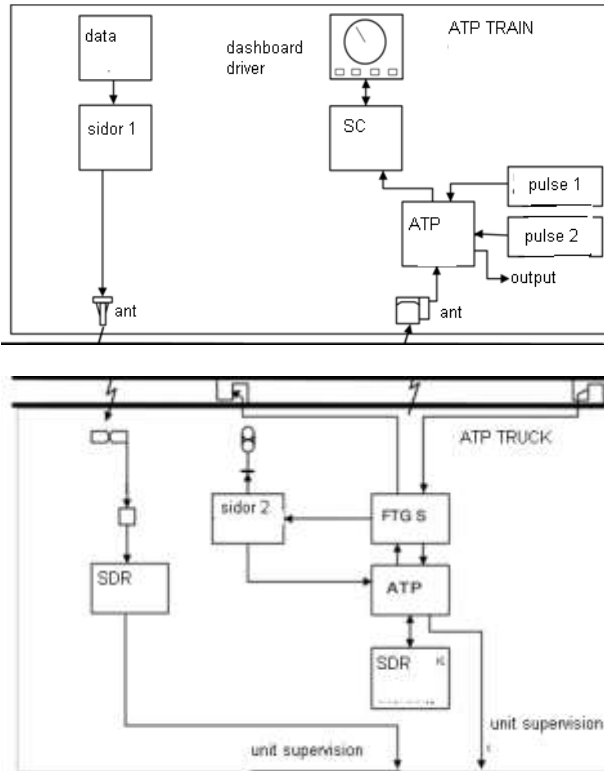

Fig. 2. Drawing imaging equipment of ATP system

The functions of the Automatic Train Protection, carried out using the following equipment:

- ATP on board equipment
- Stationary ATP equipment in the line network

The ATP equipment on the train consists of the following components:

- ATP on board unit
- Odometer pulse generator
- ATP antennas
- ATP equipment in driver's table [4].

## B. Functional Analysis of ATP Equipment on Train

The functions of the ATP unit on train are:

- Download and control telegram
- Identifying, monitoring and speed limiting
- Determination of the exact position of the train
- Determination of the maximum permissible speed
- Determination of the exact train speed

- Comparison, provision and transfer of information for the unit SP on train
- Storing interceptor indicators
- Storage of information required for the application of the forced braking
- The circuits of the ATP unit on train may be located in different modules.

The ATP unit circuits on the depot is as follows

Computers

- SIDOR (2x) absolute safe dual channel computer circuit SDR receiving equipment
- EMMI receiver circuit and mixing unit
- DEMO demodulator circuit
- USOSZ switching oscillator circuit

Distance Measuring Equipment

- WIDIS Discrete pulse odometer circuit
- RADE wheel diameter adjustment circuit

Equipment Input / Output

- OKEA Optical coupler Input / Output Circuit
- SNREL (3x) absolute safety output relay circuit power supply equipment
- SV1 voltage converter circuit (5 / 12v)
- SV2 circuit (110/24V)

Other equipment

- FILT filter circuit
- PRUEF testing circuit

The circuits of the on board ATP housed in a line printed circuit board. Every six wagon train is equipped with an on board ATP unit in each driver's cab

## C. ATP on Track

The ATP track equipment consists of the ATP track units. The track units are placed in the room of the relay along the track and associated with interlocking, the FTGS track circuits, service and diagnostic computer. The information that the ATP is OK / faulty will be transferred via the remote control system at AES. As regards the transfer of information from the line unit to trains, the FTGS track circuits used. Communication with neighboring ATP track units is performed using modem, thus allowing the collection of "telegrams" with ATP interrelated and comprehensive motion commands beyond the individual line units.

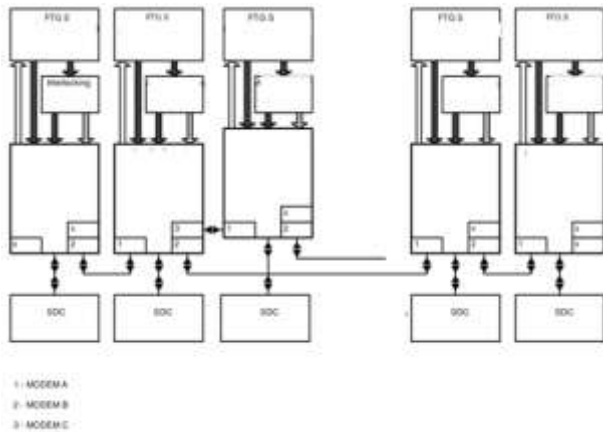

Fig. 3. Drawing imaging equipment of ATP Truck

Each ATP track unit may determine the motion commands for up to 40 track circuits by performing the following functions:

- Registration of permanent line data for each line circuit (EPROM)
- Acquisition of mutual information including information FTGS
- Handling the internal data exchange
- Identification of direction commands
- Output of ATP telegrams in FTGS track circuits and transfer to trains
- Handling of data exchange with the neighboring track units
- Control and monitoring of the feed direction of FTGS
- Acquisition of temporary restricted speed segments (entrance and deletion of limited speed sections through the diagnostic and services computer)
- Identification and output of error and diagnostic indications.

In exclusion sections:

- occupancy monitoring and exclusion of the sections
- detection of unoccupied track sections or if the occupation disappeared or the train rolling backwards.

Several modules (computers) undertake the functions to be performed by the ATP track unit. They communicate with each other using an internal serial line.

- Main computer H-SIDOR The main computer is a high standard and consists of two identical computer systems (computer system 1 and computer system 2), each of which provides absolute security from damage.

- The TELA circuit acts as an interface between the ATP track unit and FTGS track circuits and the interlock.
- The DIAGA circuit for connecting the service and diagnostic computer SDR to the track unit.
- The ANV24 circuit converts the level of the internal signal on interface level V.24.
- The MODEM circuits provide an exchange of external data with neighboring track units

Moreover, the cabinet of the ATP line unit houses the following modules:

- Power supply circuits 220V / 60V for changing the feeding direction of FTGS track circuits
- 220V / 24V rectifier unit for providing power to the ATP service unit
- Filter section with power supply filters and connections
- Coding plugs for the number of track unit
- The internal serial pipeline consists of eight data lines and two control lines (UMS and UMS\_N). Two receiving and two transmitting lines are distributed to each computer system

The unit CS with its connections to the control and display elements on the driver's table acts as a link between the driver and the ATP system. Fixes data for viewing and / or draws its own actions from this information, according to the specified mode. The following features of CS are distinguished, depending on the operating conditions

- start up CS
- ATP activation
- Error in ATP
- Main ATP function
- Secondary ATP function

The functions of CS realized using different input and output means, which are indicated below:

Output means:

- Audible indication
- Maximum allowed speed indicator
- Indicator lights, red, yellow, green, ATP- emergency brake, ATP-warning for brake, ATP-enabled movement

Input means:

- Control units

- Push start button (only ALS option)
- transfer telegram APS1-RAPS2 ML [5].

### III. EXPERIMENT AND RESULT

In 1996, a radical program of modernization and upgrading of the line of ISAP was launched. The aim of this project, completed in 2003, was to increase the transport capability and make it technically compatible with lines 2 and 3 of the under construction METRO, so that it can seamlessly collaborate with them from the beginning of the year 2000 and to make the proper preparation with the aim of working together under the same company in three years' time.

It is the task of changing the signalling system and traffic safety of trains from the intermittent control system with fixed parts of exclusion, to the identification and continuous train control system (LZB) with automatic train protection (ATP) and cab signalling. With this project, budgeted 5 billion. Drs. (The financing was secured through 2669/98 for Programmatic Agreements) and planned to be completed in December 2003. It increased reliability and succeeded to maintain a three-minute headway of trains and possibly of two-minute. The ATP system installed in vehicles 8th, 10th and 11th pick (ninth pick vehicles were sold). The Traffic Control Center of ISAP was transferred and merged with that of "Attiko Metro" in the Syntagma station.

To implement the change of signalling system two technical staff were created, one of the ISAP Company and one of the manufacturing company of SIEMENS-MAN trains.

The goal of technical staff was the study and planning of all necessary procedures for the adaptation of trains 8th and 10th pick to put into operation with the new automatic train protection system A.T. P., which was used as a tool to prevent accidents and ensuring smaller waiting time between trains resulting in increased passenger movement.

In the old technology trains (8th and 10th pick) new speedometer were replaced the old ones that had integrated needle indicating the desired speed resulting from the ATP. They placed new technology pulse code generators and step controllers on the wheels of trains so that they can measure the actual speed of the train. On each front wheel of the train mounted antennas for receiving signals from the ATP of the track. All cabs of trains were modified to create cabinets with all the ATP units inside. To operate the new system they had to replace all wirings with new ones. In the driver's cab and specifically in the driver's table incorporated appropriate audio and visual indications. Finally the cab was implemented with bridging switches to change the system.

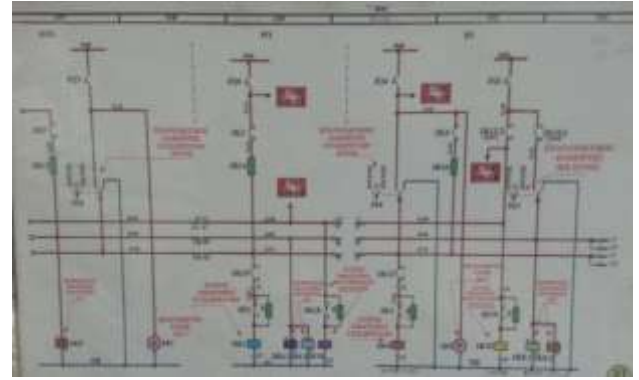

Fig. 4. Design INDUSI imaging system conversion to ATP

The INDUSI signalling system used by ISAP across the network is intermittent. This means that the information from the signals are not always transmitted as the train moves, but only in certain positions corresponding to each section. The regulations define whether the information applies to further sections.

Every train when it moves in line successively passes from one section to another. When there is a train in a section, that section is "occupied" as is the term applied. This occupation is marked by specific regulations of signalling. The marking is firstly given by the signals.

The main line signals inform us about the state of the next track segment while the signals of station area inform us about the state of a route.

The signal meets the train in the direction of movement before the first wheel short-circuits the corresponding sector or the corresponding route. Which means that, the signal is placed before the section that gives information to.

The distance from the signal to the section is termed the overlapping length or overlap section or overlap distance. The signal, which meets the train, provides information about whether to continue the progress of the train in the following section or not.

When the signal is "green," it means that the continuation of motion is allowed. We call this signal "open". Any other signal aspect as "red" signal, signal off, no signal in place where it should be, means that the continuation of the train movement is forbidden.

Also in each main signal there is the signal blocking, the so-called electromagnetic blocking of course.

The blocking, acts on the systems of the train and causes automatic braking when the driver does unintentionally exceeded of closed signal. We must mention here that line apart from the role of being the "way" for the scrolling of the train wheel is used also to give information to the signal for its condition, i.e. if it is free, busy or damaged.

The ATP system is able to automate all these processes. Continuously gives information to the driver's cab about the status of the track and the desired speed, without the need of a signal. ATP can also automatically brake the train in case of



any incident. Equally important is the fact that ATP can allow or not, which of the doors must open (left or right side of the train, depending on the location of the pier). The processes run by ATP system and can be monitored by the system control centre which in case of failure is able to act immediately in order to achieve the smooth operation of the rail network.

The transportation of ISAP carrying out the movement of passenger trains on the Piraeus-Kifissia line with the ATP system ensures the following qualities characterizing the correct movement of trains.

- Security to avoid accidents.
- Regularity in transit waiting time of passenger trains from stations.
- Provide the shortest time distance permitted by the conditions, between the trains.
- To respond to the social needs of the region.
- Optimization of the budget in operation of the transportation project

Therefore, the implementation of the ATP system is the most reliable choice as far as the purpose of the utmost importance of railway companies which is the safety of passengers and goods. At the same time the smaller headway between trains is achieved, in order to carry more passengers. Finally, the use of ATP system in ISAP train network was an important innovation which helped the company's modernization and eventually the merge with the AMEL and TRAM to a new transportation company called STASY A. E.

#### IV. CONCLUSIONS AND FURTHER RESEARCH

Despite the security advantages provided by the ATP system, it also has its limitations. One example is the limited capacity of the line network. The ATP system described uses the concept of speed zones, which progressively reduce the speed of a train as it approaches a red signal. From the description it appeared that in order to guarantee that there is no risk of collision, it is necessary to maintain free an unoccupied part of the sections as a zero speed zone extension before the occupied one. The imposition of an additional signalized section between two successive trains, increasing the distance between them also increases and the time distance, that reduces the number of available channels (paths) for the circulation of trains per unit of time. Technical barriers related to interoperability of trains - ie their ability to move on any section of the network – continue to impair competitiveness in the railway sector.

These technical barriers obstruct the development of rail transport at European level, while at the same time, road transport develop without such barriers. To restore all incompatibilities, the European Rail Traffic Management System was developed, also known as ERTMS. The aim of this system is to establish a single signalling standard that will be the cornerstone to achieve interoperability of the trans-European railway network, which will also be adapted from the rest of the world. The ETCS (European Train Control

System) is about a train control system that provides a stable signalling system and paves the way to the border movements of conventional trains, high speed and freight trains. As a result greater availability and knowledge of the condition of trains is achieved and therefore the speed of trains is increased and the distance between two successive trains is reduced. It enables sophisticated supervision of the railway line equipment and rolling stock. The GSM-R (Global System for Mobile for Railways). Based on the GSM standard but it uses different frequencies for rail services. It is the radio system used to exchange information (audio and data) between the rail control devices and the adjacent to the train equipment.

The three "levels" of the ERTMS / ETCS system

1. With the ERTMS / ETCS, the trackside system transmits information to the driver, which enables him to calculate continuously the maximum speed of the train. It is used on routes where there are lineside signals (lights and signboards). This information can be transmitted by standard radio beacons (Eurobalises) positioned along the line. In this case it is about ERTMS / ETCS level 1
2. The information can also be transmitted by radio communication (GSM- R), in this case we have ERTMS / ETCS Level 2 and we do not need to have lineside signals, which allow substantial savings in investment and maintenance.
3. Finally, at Level 3 trains have to be able to send out themselves their precise position, which allows particularly optimization of line capacity and reduce ground equipment [6].

New technologies like radio frequency identification devices, geographical information systems, receiver miniaturization and the reduction of energy consumption in collaboration with telecommunications created the conditions for the emergence of many new developments using satellite positioning. To Galileo is a global navigation satellite system (GNSS) under construction by the European Union and the European Space Agency which can provide positioning, navigation and precision timing to achieve interoperability at the European, and not only, Railway Networks. [7].



Fig. 5. General form GALLILEO system



The Galileo program is based on a comprehensive system of 30 satellites placed into orbit of medium height, about 24.000 km, to cover on regular basis almost the entire globe. The way the system works is summarized as follows: satellites have an atomic clock that measures the time with great accuracy. The satellites emit personalized signals indicating the precise time the signal leaves the satellite. The terrestrial receiver that may be incorporated e.g. in a mobile phone, has stored in its memory the exact coordinates of all satellite orbits. Reading the incoming signal, it recognizes the satellite-transmitter and determines the time the signal took to reach up to it and, therefore, calculates the distance separating him from the satellite. Once a terrestrial receiver simultaneously receive the signals from at least four satellites, they are able to calculate the exact position.

The introduction of satellite navigation into ETCS / ERTMS will contribute to the increase of efficiency in lines with high traffic density and reduce costs at low density and regional lines. The Galileo, combined with telecommunication services, will offer to railway operators a supervision system that can provide the driver of the train and the Central Station with additional means for controlling the various functions. Applications are also developed for proximity alarms, which are activated when two trains on the same line are close by, and for the speed limit alarms indicating that a train has exceeded the permitted speed for that section of the track.

Galileo will significantly help organize and improve the maintenance of mobile equipment stocks will also enable the efficient detection of goods and will help to simplify the pricing of routes and supervision of the lines used. The equipment of the engine and carriages with Galileo receivers will allow operators to monitor their vehicles and will effectively provide their customers with updated information. Satellite navigation services also find use in construction works where used very accurate differential techniques are. [8]

Eventually Galileo will be able to offer numerous railway applications, ranging from the control and monitoring of traffic, wagons and loads to signalling trains, the route survey and passenger information services. Specifically, Galileo will make it possible to reduce the time distance between trains and therefore increase the frequency of service. Furthermore, it will make it easier to locate the entire rail fleet

#### V. REFERENCE

- [1] Railway News, Greek Press, 2010
- [2] Terzopoulou Despoina, Thesis:Greek Railways : Intertemporal value of train on transportation and contribution on tourism., ATEI of Crete, Tourist Business, Heraklion, 2013
- [3] [http://portal.survey.ntua.gr/main/labs/roads/Roads-g\\_files/Edu-g\\_files/Edu-72-g\\_files/3-Shmatodothsh.pdf](http://portal.survey.ntua.gr/main/labs/roads/Roads-g_files/Edu-g_files/Edu-72-g_files/3-Shmatodothsh.pdf)
- [4] Dolka Aggeliki, Managing director notes, ISAP
- [5] SIEMENS, ATP system functionality manual, Attico Metro
- [6] Giannakos K., «Selected topics in railway», University of Thessalia, 2008
- [7] Green Paper on Satellite Navigation Applications, Commission of the European Communities, Brussels, COM(2006) final
- [8] Ekaterini Kotsifakis, Bachelor thesis: Applications of the European Satellite Navigation System , Gallileo, Athens, 2008

# IJEAST

INTERNATIONAL JOURNAL  
OF ENGINEERING APPLIED SCIENCE  
AND TECHNOLOGY

## ABOUT IJEAST

International Journal of Engineering Applied Science and Technology (IJEAST) is a peer-reviewed, open access journal that publishes high-quality research papers in the field of Engineering, Applied Science and Technology.

IJEAST aims to provide a platform for researchers, academicians, and professionals to share their innovative ideas, research findings, and practical experiences with the global scientific community.

## FOCUS AREAS

- Engineering
- Applied Science
- Technology
- Innovation & Development
- Interdisciplinary Studies



### PEER REVIEWED

All submissions are rigorously peer reviewed to ensure quality.



### OPEN ACCESS

Free and unrestricted access to research for all.



### GLOBAL REACH

Connecting researchers and professionals worldwide.



### TIMELY PUBLICATION

We ensure a swift and efficient publication process.



For more information, visit our website  
[www.ijeast.com](http://www.ijeast.com)



INTERNATIONAL JOURNAL  
OF ENGINEERING APPLIED SCIENCE  
AND TECHNOLOGY

✉ [editor@ijeast.com](mailto:editor@ijeast.com)

🌐 [www.ijeast.com](http://www.ijeast.com)

📍 India



2455-2143