



# IJEAST

INTERNATIONAL JOURNAL  
OF ENGINEERING APPLIED SCIENCE  
AND TECHNOLOGY



**VOLUME : 5    ISSUE : 6    Print / Issue Publication Date: 21-Dec-2020**



**ISSN : 2455-2143**



**DOI : 10.33564/IJEAST.2020.v05i06.048**

Indexed In



[WWW.IJEAST.COM](http://WWW.IJEAST.COM)

[editor@ijeast.com](mailto:editor@ijeast.com)

# SWARM ROBOT FOR IRRIGATION BASED APPLICATION

Sk. Bilal, V.Meghanethra, Sk.Fareed  
Department of Electronics and Communication Engineering  
SRM Institute Of Science And Technology, Kattankulathur  
SRM Institute Of Science And Technology, India

**ABSTRACT:** The concept of smart agriculture is developing, as the sensors can give information in regards to the territories of their development. The function of this project is to gauge the humidity level of soils in crops through sensors. The humidity level measured is given to Arduino and as indicated by which water siphons are worked. In this technique, we are also implementing swarm concept which consists of a master and a slave robot. The master robot will be stationary and slave robot will perform the task given to it by the master robot. The instructions are given from an android application to master and the master will give it to slave and it moves accordingly. The main advantage of this swarm concept is we can control the robot from a certain distance and use it to water the plants by measuring their humidity levels.

## I. INTRODUCTION

The swarm robot means "Group of Robots".Swarm robotics is another methodology for the coordination of multi-robot frameworks that comprises of enormous number of physical robots. This concept is developed by observing the artificial swarm intelligence, as well as organic investigation of bugs, ants and different fields in nature, where swarm conduct occurs. Swarm robot comprises of master and slave robots. In swarm robot there can be one or more master or slave robots. By utilizing this idea we can broaden the communication region by utilizing Zigbee module. The fundamental goal of this project is to build up a correspondence among master and slave robot utilizing Zigbee and perform task allocated to slave robot.

Here in this project, we are going to combine swarm robotics concept as well as a plant watering system to the slave robot which waters the plants by checking the humidity level of the soil using a soil moisture sensor. if the amount of water is below 30 percent in the soil it means dry soil then automatically water is poured over and if there is a plant having moisture up to 50 percent then the robot will not provide water to the plant. In this project the slave robot is controlled using android application from smart phone. The reason for this project is to give the adequate water the plant is required and to utilize water effectively.

## II. WORKING

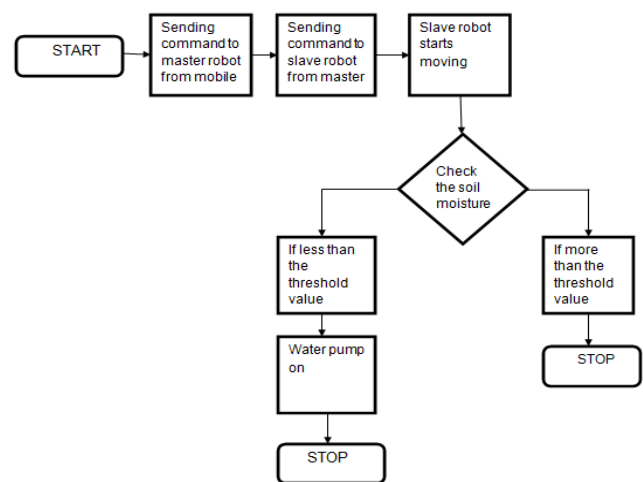

Fig.1.Flow Chart

- 1) The working of this project follows the following steps. First the commands to the master robot from smart phone through an application, where the smart phone is connected via bluetooth module to the master robot.
- 2) Then the commands received by the master robot is sent to the slave robot through Zigbee module.
- 3) The slave robot will follow according to the commands given to it and starts moving
- 4) It will go near a plant and checks the humidity level of the plant using a soil moisture sensor which is connected to the slave robot.
- 5) If the humidity level of soil is below the threshold value, then the water motor pump will be turned on and water is poured over the plant.
- 6) If it is exceeding the threshold value, then it will stop.



### III. SYSTEM DESIGN

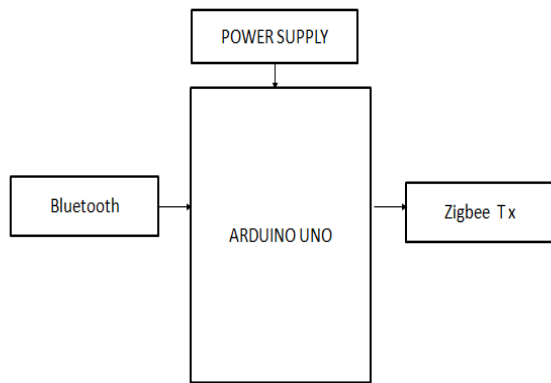

Fig.2. Block Diagram of Master Robot

The master robot consists of a Bluetooth module (HC-05/06), a Zigbee transmitter and an Arduino Uno board. The power supply to the master robot can be given from a 5V adapter or from a laptop by using an arduino cable connector.

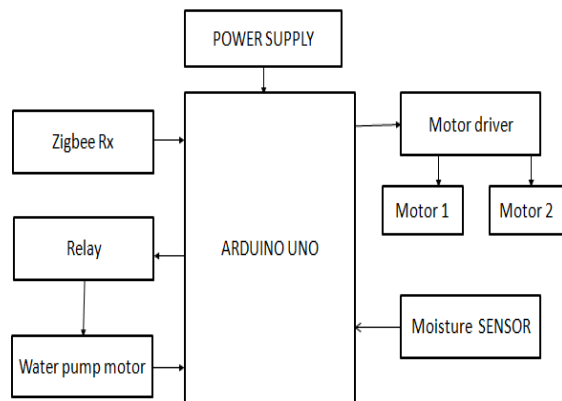

Fig.3. Block diagram of Slave Robot

The slave robot consists of an Arduino Uno board, Zigbee receiver, Motor driver, two motors, a relay, a water pump motor, 12v battery and a soil moisture sensor. The slave robot receives instructions from master robot through zigbee and it follows the instructions received. This robot is utilized to quantify the humidity level of soil and to water the plants.

### IV. EXISTED METHOD

The Normally available methods for irrigation are sprinkler and drip irrigation. The sprinkler system sprinkles the water into air and breaks water into droplets like a rain. The drip irrigation system directly gives the water to the root by pipelines connected under the plants, this method is effective than sprinkler. These systems are effective but less efficient, it will not stop after the plant

got required amount of water and often there is loss of water.

### V. PROPOSED METHOD

In our proposed work, we focus on developing a self-sufficient water system work and set up a savvy answer for irrigation problem of developing countries by using the master and slave concept from swarm robotics. This system checks the humidity level of soil by a sensor and gives the water according to it. Here the system is controlled from a smart phone through an android application.

### VI. EMBEDDED SYSTEM

**Arduino:** Arduino Uno is a type of microcontroller which is supported by ATmega328P (datasheet). It has total 28 pins of which 14 are used as input/output pins (sometimes 6 pins are used as PWM outputs), 6 are used as analog inputs, it has a 16MHz quartz, a USB interface, an ICSP header and a reset button. In this project, we use arduino uno with VGA port to interact with the zigbee board. To make the board run one can connect it with a device which has USB Port or to a battery.

**ZigBee:** Zigbee is a high level specification for the usage of lightweight low power wireless radio networks based on IEEE standard 802.15.4-2003. Zigbee is for devices that are not needed for data transmission at a higher rate, that need easy wireless networking. The Zigbee interface platform is intended to be easier and cheaper than most WPAN, like Bluetooth or more general wireless communication such as Wi-Fi. Wireless illumination switches, house energy control, traffic management and other home and industrial products that include short-range low-speed wireless data transfer include applications.

**Soil Moisture sensor:** The Sensor uses a dielectric permittivity measuring device. Dielectric permittivity in the soil is water dependent. The sensor tests the water level across the whole duration of the instrument. It is made of two probes used for volumetric water quality measurements. The two probes cause the current to flow through the ground and then the resistance value is determined. The module also includes a potentiometer which sets the threshold value and compares the threshold value to the LM393 comparator. If there is more water the resistance will be less, if there is less water the resistivity will be higher.

**Bluetooth Module:** The bluetooth module used in this project is a HC-05 / 06 module which is perfectly suitable for swarm robot concept. The HC-05 bluetooth module has a Master and Slave configuration. The specifications of this bluetooth are, it has protocol of bluetooth V 2.0+EDR, it works with the power supply of 3.3V-5V DC 50mA, it has frequency upto 2.4GHz of ISM band, it has GFSK modulation, it has sensitivity less than equal to -84dBm at 0.1 percent of BER, it can work

at temperature from -20 to +75 centigrade. This module has a CSR bluecore 04-external single chip with CMOS system and AFH feature.

## VII. RESULT

### Sending instructions to master:

Here the instructions are given to the master from smart phone by connecting through bluetooth and the control is given from android application available in playstore.

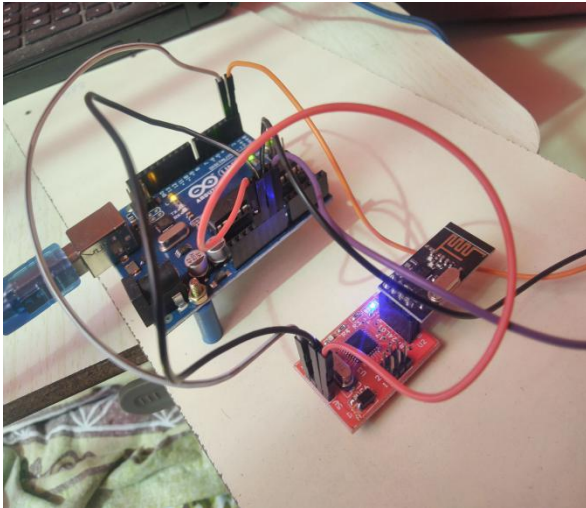

Fig.4.Master Robot

### Instructions received by slave:

Here the instruction given to master is send to slave by zigbee transmitter in master and is received by zigbee receiver in slave and it starts moving accordingly. It goes near a plant and soil sensor is put into soil and soil moisture is measured and it gives water.

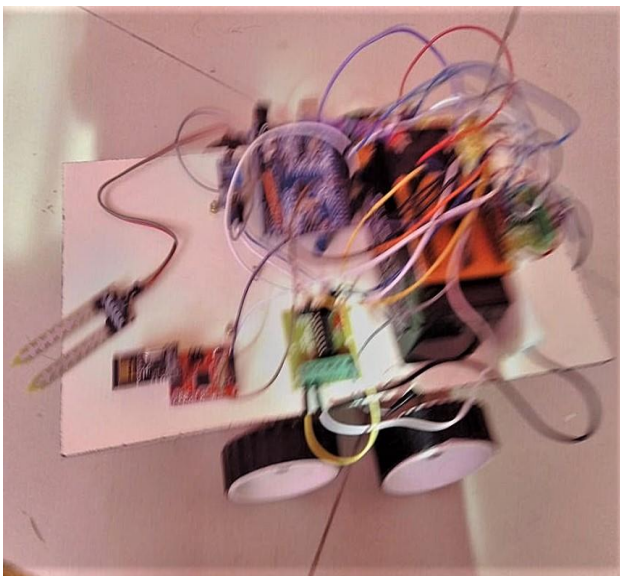

Fig.5.Slave Robot

## VIII. CONCLUSION

The swarm robot for irrigation based application is based on the swarm robotics concept with a plant watering system added to the slave robot. Controlling of the slave robot is done from an android application through a smart phone which is connected to the master robot through a bluetooth module. Whatever the instructions given to the master are sent to the slave by a zigbee transceiver module. The slave robots task is to perform humidity level check of soil and to water the plants, for that a soil moisture sensor is placed on slave robot. If the humidity level is lower than the threshold value the slave robot will water the plant automatically and it waters only sufficient water to the plant not more or less. Thus, there will be no wastage of water and not more people required to do this job and we can operate this robot from a distance. The arduino software used in this method is very efficient and produced correct output.

## IX. REFERENCES

1. Albani, D., IJsselmuiden, J., Haken, R., and Trianni, V. (2017). "Monitoring and mapping with robot swarms for agricultural applications." *2017 14th IEEE International Conference on Advanced Video and Signal Based Surveillance (AVSS)*, IEEE. 1–6.
2. Carbone, C., Garibaldi, O., and Kurt, Z. (2018). "Swarm robotics as a solution to crops inspection for precision agriculture." *KnE Engineering*, 552–562.
3. Hasan, Y. (2017). "Swarm robots and their applications." *Journal of Computer Engineering*, 19(1), 46–47.
4. Rafifi, R. H., Das, S., Ahmed, N., Hossain, I., and Reza, S. T. (2016). "Design & implementation of a line following robot for irrigation based application." *2016 19th International Conference on Computer and Information Technology (ICCIT)*, IEEE. 480–483.
5. J. Senthil Kumar, E. Sweetline Sylvania, C. Srijayasri, G. Sharmila. (2017) Task Coordination and Control between Swarm of Robots for assisting Farmers. *International Journal of Advanced Research in Electronics and Communication Engineering (IJARECE)* Volume 6, Issue 3, March 2017.
6. Devdutt, Ishlok Vashistha, Vimlesh Singh, Priyanka Bansal, Abhiruchi Passi. (2017) PLANT WATERING ROBOT "PLANT O BOT". *IJCSMC*, Vol.6, Issue.4, April 2017.
7. Shamshiri, R. R., Weltzien, C., Hameed, I. A., Yule, I. J., Grift, T. E., & Balasundram, S. K. (2018). Research and development in agricultural robotics: A perspective of digital farming. *Int J Agric & Biol Eng*, 11(4), 1-14.
8. Ju, C., & Son, H. I. (2019). A distributed swarm control for an agricultural multiple unmanned aerial vehicle system. *Proceedings of the Institution of*



*Mechanical Engineers, Part I: Journal of Systems and Control Engineering*, 233(10), 1298-1308.

9. Khaluf, Y., Vanhee, S., & Simoens, P. (2019). Local ant system for allocating robot swarms to time-constrained tasks. *Journal of Computational Science*, 31, 33-44.
10. Trianni, V., IJsselmuiden, J., & Haken, R. (2016). *The Saga Concept: Swarm Robotics for Agricultural Applications*. Technical Report. 2016. Available online: <http://laral.istc.cnr.it/saga/wp-content/uploads/2016/09/sagadars2016.pdf> (accessed on 23 August 2018).
11. Tan, Y. (2013). Swarm robotics: collective behavior inspired by nature. *J Comput Sci Syst Biol*, 6, e106.
12. Rafael, P., & Heitor, S. L. (2012). Theory and New Applications of Swarm Intelligence. *InTech. Janeza Trdine*, 9, 51000.

#### ACKNOWLEDGEMENT

We would like to express our deepest gratitude to our guide, **Dr.S.Yuvaraj** (Asst.Professor, Department of Electronics and Communication, SRM Institute of Science and Technology, Kattankulathur campus, Chennai) his valuable guidance, consistent encouragement, personal caring, timely help and providing us with an excellent atmosphere for doing research. All through the work, in spite of his busy schedule, he has extended cheerful and cordial support to us for completing this research work.

# IJEAST

INTERNATIONAL JOURNAL  
OF ENGINEERING APPLIED SCIENCE  
AND TECHNOLOGY

## ABOUT IJEAST

International Journal of Engineering Applied Science and Technology (IJEAST) is a peer-reviewed, open access journal that publishes high-quality research papers in the field of Engineering, Applied Science and Technology.

IJEAST aims to provide a platform for researchers, academicians, and professionals to share their innovative ideas, research findings, and practical experiences with the global scientific community.

## FOCUS AREAS

- Engineering
- Applied Science
- Technology
- Innovation & Development
- Interdisciplinary Studies



### PEER REVIEWED

All submissions are rigorously peer reviewed to ensure quality.



### OPEN ACCESS

Free and unrestricted access to research for all.



### GLOBAL REACH

Connecting researchers and professionals worldwide.



### TIMELY PUBLICATION

We ensure a swift and efficient publication process.



For more information, visit our website

[www.ijeast.com](http://www.ijeast.com)



INTERNATIONAL JOURNAL  
OF ENGINEERING APPLIED SCIENCE  
AND TECHNOLOGY

✉ [editor@ijeast.com](mailto:editor@ijeast.com)

🌐 [www.ijeast.com](http://www.ijeast.com)

📍 India



2455-2143