



IJEAST

INTERNATIONAL JOURNAL
OF ENGINEERING APPLIED SCIENCE
AND TECHNOLOGY



VOLUME : 7 ISSUE : 01 Print / Issue Publication Date: 07-Jul-2022



ISSN : 2455-2143



DOI : 10.33564/IJEAST.2022.v07i01.051

Indexed In



WWW.IJEAST.COM

editor@ijeast.com



CHILD MONITORING SYSTEM USING GPS CHILD TRACKING SYSTEM

Sadhana B

Assistant professor

Department of Information Science and Engineering CEC Bantwal.

Navya A, Nidhishree, Vidhyashree, Vishwa

Students

Department of Information Science and Engineering CEC

Abstract— Today, parents are working hard and looking after their kids at the same time. Due to the increasing security risks faced by children, both the parents need to monitor their child & #39; s activities. This paper proposes a system that uses an Android phone to monitor the child & #39; s activities. The system can also provide the parents with the necessary information about their child & #39; s safety. The paper also shows how this system can be used to create a safety zone around the child. The system can monitor the child & #39; s activities and create a safety zone around the child. It can also provide the parents with the necessary information about the child & #39; s location. The system is equipped with a video camera that can be operated using the instructions from the Android phone & #39; s software hand function. The video camera can also be used to capture the child & #39; s movements. This project & #39; s major goal is to create an IoT-based Child Monitoring System that will allow parents to watch and detect their children & #39; s activities even when they are away from home. It is an innovative, smart, and protected Child Monitoring System designed to efficiently nurture a newborn. This approach takes into account all of the minor elements necessary for the child & #39; s care and protection at the institution and elsewhere. The usage of technologies/methodologies such as the Internet of Things (IOT), Live Video Monitoring System, Cloud Computing (Data Storage), and User Friendly Web Application helps to build smartness and innovation (for User Controls). Different Sensors/Modules are fitted to the child in order to detect each and every activity. All data collected from sensors/modules will be kept in the cloud and examined on a regular basis.

Keywords—component; child safety, live video monitoring, school bus tracking, web application.

I. INTRODUCTION

Things with identity communication devices were the

forerunners of the Internet of Things (IoT) idea. Remote computers linked to the Internet could track, control, and monitor the gadgets. The Internet of Things (IoT) expands the use of the Internet by allowing gadgets and physical things, or & #39; Things, & #39; to communicate and so form a network. & quot; Internet & quot; and & quot; things & quot; are the two most important words in IoT.

These days, parents are concerned about their children & #39; s safety and want to keep a constant eye on them. Since this is physically impossible, we have developed a safety video monitoring system that allows parents to watch and track their children & #39; s activities from anywhere in the world. The big issue of a missing child can be remedied with the use of a child monitoring system. For elders this system is essential to keep track of their child. To find their child & #39; s position, the Web application employs GPS and telephonic services. As this application works in the background, it covertly obtains all of the Message Details, Video Details, and precise Location without their awareness. so, that no one can recognize it. also live video monitoring feature is added. We are also providing recording of video automatically so that when ever parent busy with some work they will watch it later. Child contain Sensor (transmitter) and Institution or Bus consist of Receiver when child get contact of the receiver it catches the child location details.

This programme delivers all of the data from the child & #39; s sensor to the server, and then from the server to the parent & #39; s phone in a short amount of time. This app is separated into two parts: one for parents to see all of their children & #39; s activities, and the other for teachers to see all of their students' activities., where the teacher can update the child information to the parents mobile through Application, so that it is very easy to collect all information about child. Along with parents can know about the growth of their child in the child caring institution. For the safety of the child this system build and it must be accepted by institution and parents. Internet of Things (IoT), International Journal of Engineering Applied Sciences and Technology, 2016 Live Video Monitoring System, Cloud Computing (Data Storage), and User-Friendly Web/Android



Application are some of the technologies used in this design (for User Controls).

We are all familiar with the difficulties that parents endure in raising their children, especially when both parents work. In such instances, giving 24 hours of time is nearly impossible. As a result, we need to create something unique that will allow parents to keep a constant eye on their child/infant and be notified if anything unusual happens. As a result, we've devised a plan to create a Smart Child Monitoring System based on the Internet of Things, which will allow parents to monitor their children even when they are away from home and detect every activity of the child from anywhere on the planet. Home & detect every activity of the Child from any distant corner of the world.

II. LITERATUREREVIEW

The global position system (GPS) based child care system using RSSI Technique [1]. This paper proposed the GPS technology helps to determine the exact position of the child. A data from received signal strength indicator (RSSI) is extracted out from the Bluetooth connection Using which the distance between parent and child is found.

An alert is triggered when the distance between the parent and child is far apart for a certain range. The Remote Video Monitoring System Based on Embedded Linux and GPRS [2]. This video monitoring system based on embedded Linux and GPRS (General Packet Radio Service) network. lo hardware takes ARM9 S3C2410 processor for centralization, in virtue of SDRAM, USB, GPRS module etc. the main function realized by C programming to achieve real-time camera data acquisition, image compression and network transmission through GPRS module. Monitoring center receives image data and displays after connects with the terminal. It is easier to be used in

windows system. Image data can be transmitted to the monitoring center in 3-6 seconds after JPEG compression.

The Children Safety and School Bus Tracking Solution [3]. School bus monitoring is an effective major to restrict the mishaps. This paper proposes an embedded system which focuses on children safety, tracking of school bus and exact we also provide with the help of longitude and altitude positioning of GPS and sending information through SMS. Each student possesses an RFID tag on his own smartcard which is useful for identifying the student. Two IR sensors are used to check whether a student is arriving or leaving bus. Hence, we have proposed "LPC 2148" based embedded system which provides a complete solution to children safety and school bus tracking. IoT based School Bus Tracking System [4]. This project recommends an android based solution which assists parents to track their children location in real time. To track the location Active RFID module is used and to identify the identity of the child a biometric identification is used which is in built in the system. Whenever a child boards a bus, the biometric identification is done in the bus, and the system will identify the child and update log on a server will send notification to the parents which consist of current location and time. Parents can see the location of bus, they will be notified when the children is getting into a bus or getting down from a bus. Smart IOT Device for Child Safety and Tracking [5].Where the system is developed using Link It ONE board programmed in embedded C and interfaced with temperature, heartbeat, touch sensors and also GPS, GSM & digital camera modules. The novelty of the work is that the system automatically alerts the parent/caretaker by sending SMS, when immediate attention is required for the child during emergency.

SL NO.	TITLE OF THE PAPER	METHODOLOGY USED/ TECHNOLOGIES	OBSERVATION MADE	SHORTFALLS/ DRAWBACKS
[1]	Global position System(GPS)	Child node device consists of Bluetooth GPS receiver and Parent node device is Mobile apparatus.	Child node and the Bluetooth of Parent node are turned on. When the child node is turned on, the GPS receiver is started to calculate its location by the received signal from satellites.	The current proposed system could not save the location of child. Therefore, the addition of database is recommended.
[2]	Remote Video Monitoring System	This video monitoring system based on embedded Linux and GPRS (General Packet Radio Service) network. Monitor terminal hardware takes ARM9 S3C2410 processor for centralization, in virtue of SDRAM, USB, GPRS module etc.	The main function realized by C programming to achieve real-time camera data acquisition, image compression and network transmission through GPRS module.	Because of postpositional buffer of TCP protocol stack built in MC384 module is limited, so data will be lost if the serial write rate higher than GPRS transfer rate.
[3]	Children Safety and School Bus Tracking Solution	This paper proposes an embedded system which focuses on children safety, tracking of school bus and exact location of school bus with the help of longitude and altitude positioning of GPS and sending information through SMS.	Each student possesses an RFID tag on his own smartcard which is useful for identifying the student. Two IR sensors are used to check whether a student is arriving or leaving bus. We also provide speedometer which checks speed of bus.	The range of the RFID reader is as low. The RFID can be replaced with a better reader or more reliable identification methods like biometric identification.
[4]	Wearable device for the safety and security of women and girl children	The physiological signals that are analyzed are galvanic skin resistance and body temperature.	Real-time monitoring of data is achieved by wirelessly sending sensor data to an open source Cloud Platform. Analysis of the data is done on MATLAB.	Accurate recognition of a dangerous situation is a complex matter.
[5]	School Children Transportation Safety Enhancement	The system consists of two main units, a bus unit and a school unit. The bus unit the system is used to detect when a child boards or leaves the bus.	The system has a developed web-based database-driven application that facilitates its management and provides useful information about the children to authorized personal.	The module may not be convenient for children and wireless deployment is expensive. One disadvantage of this type of applications is that they work only in a limited range. The major drawback of this system

Figure1: Summary of Literature Review



III. METHODOLOGY

In this project, a child belt is attached with sensor in order to keep track of child's Activity. Whenever child get into school bus from home the parents will get message and through GPRS the location of child is monitored by parents through a developed software.

Whenever Child get into classroom the camera inside classroom get activated and the video clip is send to parents. Here Cloud Computing is used to store video. And whenever child play in playground the information is sent to parents. Hence these are safety zone for child. Suppose if child goes out of these safety zone then the alert message is

sent to parents and then through GPRS. The Teachers can also update child's activity and day to day summary to parents and also the institution can keep track of children from home to school till school to home. There by reduces stress of parents on child's safety. Since parents are specific about child security institution can use this product thereby can have high productivity in market. Fig. 2 shows the pictorial representation of Child Monitoring System using GPS. Raspberry Pi2 B act as an interface to setup connection between Camera and GSM module. Module of GSM used here helps to transmit the notification alerts to the user. The Camera records the video of the classroom.

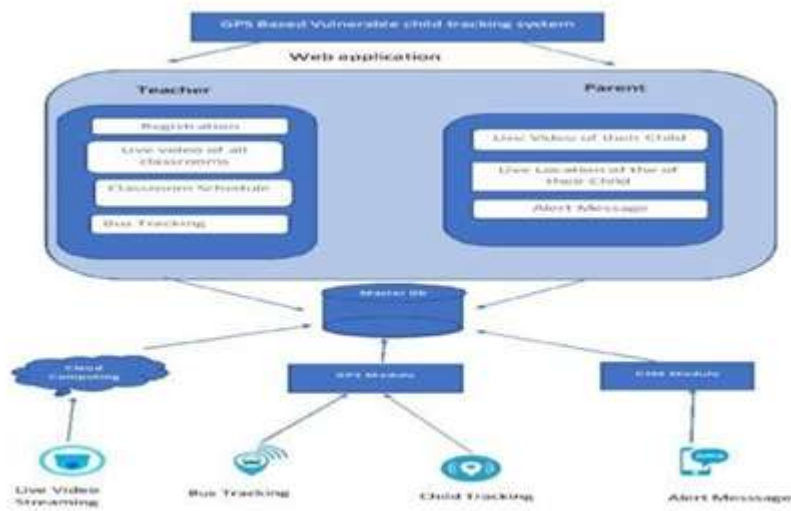

Figure 1 : Block diagram of child Tracking System

Figure 2: Block diagram of Child Monitoring System

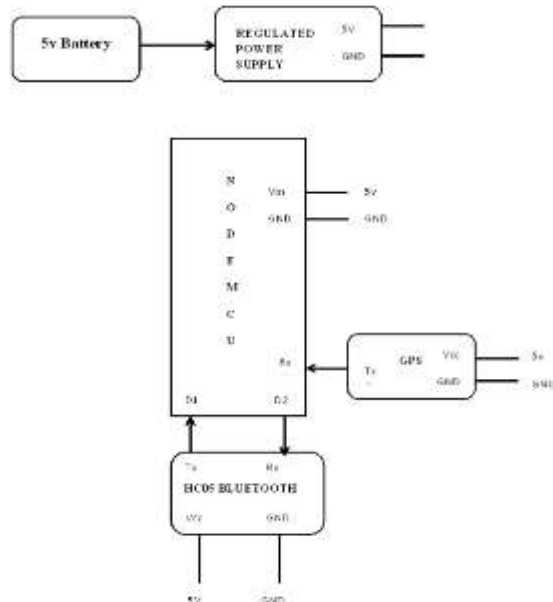

Figure3: Architecture Diagram

Above diagram shows the pictorial representation of Bus Monitoring System. The AT mega 2560 helps to connect Power Supply device with other hardware components. The GSM Module helps to send or receive the messages. And the GPS Module to get the Location information.

AT Mega 2560: The AT Mega 2560 is a RISC-based 8-bit CMOS microcontroller with low power consumption. An external power supply can be used to power it. An AC-to-DC adapter or a battery can be used to provide external power.

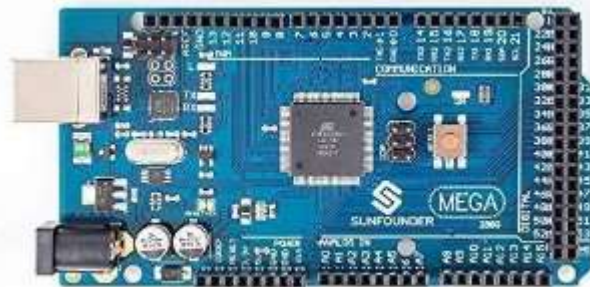

Figure 4: AT Mega 2560

Camera:

The Camera is a component where some activity of the object or surrounding is recorded and shown through some output device like monitor or display screen. Here, we using live streaming videos to capture the activities of movable object and stored.

Power Supply:

The voltage regulator's shutdown is solely for the purpose of preventing the regulator from squandering power.

The quiescent current of a linear regulator is normally 10-20mA. With AT- Commands, you may effortlessly turn off the GSM Module.

As a result, the easiest option to power the module directly

would be using a single cell lipo battery.

Node MCU:

Open source prototyping board designs are available for NodeMCU, an open source firmware. The name "NodeMCU" will be a combining of the words "node" and "MCU" (microcontroller unit).

NodeMCU is an open source platform based on the ESP8266 that allows things to be connected and data to be transferred using the Wi-Fi protocol. Furthermore, it may resolve multiple of the project's demands on different way by providing some of the most significant functionalities of microcontrollers such as GPIO, PWM, ADC, and so on.



Figure 5: Node MCU

A. GPS Module:

GPS modules are made up of tiny processors and antennas that receive data directly from satellites via specific radio frequencies. It will then get timestamps from all visible satellites, as well as other information. The module's

antenna can precisely compute its position and time if it can identify four or more satellites.



Figure 6: GPS Module

IV. IMPLEMENTATION

A. Algorithm:

- Step 1: Admin can register a parent in the system with child details.
- Step 2: Parent login to the System using Username and Password.
- Step 3: Child wear the smart belt.
- Step 4: Belt contains the readable sensor like GSM/GPRS Module to track child location and send message. International Journal of Engineering Applied Sciences and Technology, 2016
- Step 5: System track the current location of child. Location issends to the parent's smart phone.
- Step 6: If location can't be tracked or child location is out ofschool region alert message is send to parent phone immediately.
- Step 7: When child is in the classroom, the live video recordsare sends to parent as well as Administer module.
- Step 8: Cloud computing is used to store previous recorded video and compute live streaming.

B. User Interface:

- User Login Form.
- Admin Login Form.

C. Functional Requirement:

- System should track the location.
- System should support the live video monitoring.
- System should properly interact with the smart belt.
- System should be able to store and view the recorded videos.
-

V. RESULTS

- On successful completion of the project, though parents are far from child they can monitor when child reached school, what child is doing in classroom and playground.
- And whenever child goes out of the school boundary the parents are notified about it and using GPRS parents can locate where the child is. Hence parents are aware of eachaction of their child though they are not with them.
- Also, the teachers can update about the child performance in school to their parents using this software.
- And any meeting schedules can be updated. Hence, we are trying to simplify the lives using our project.



Figure 7: Home page

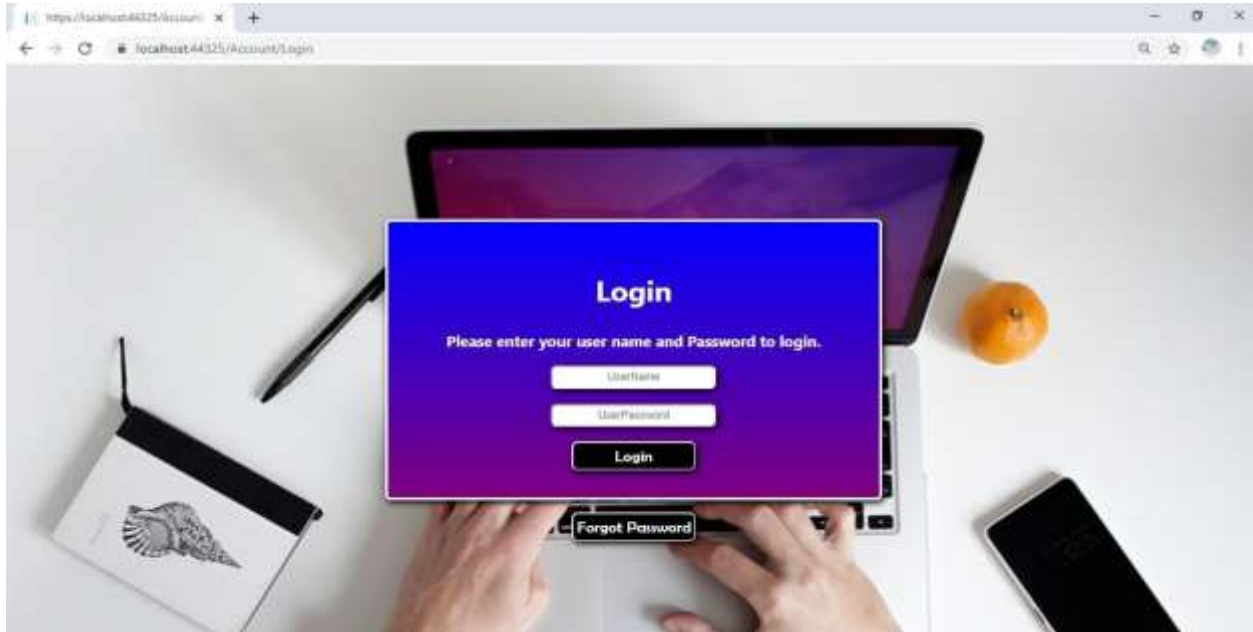

Figure 8: Login Page

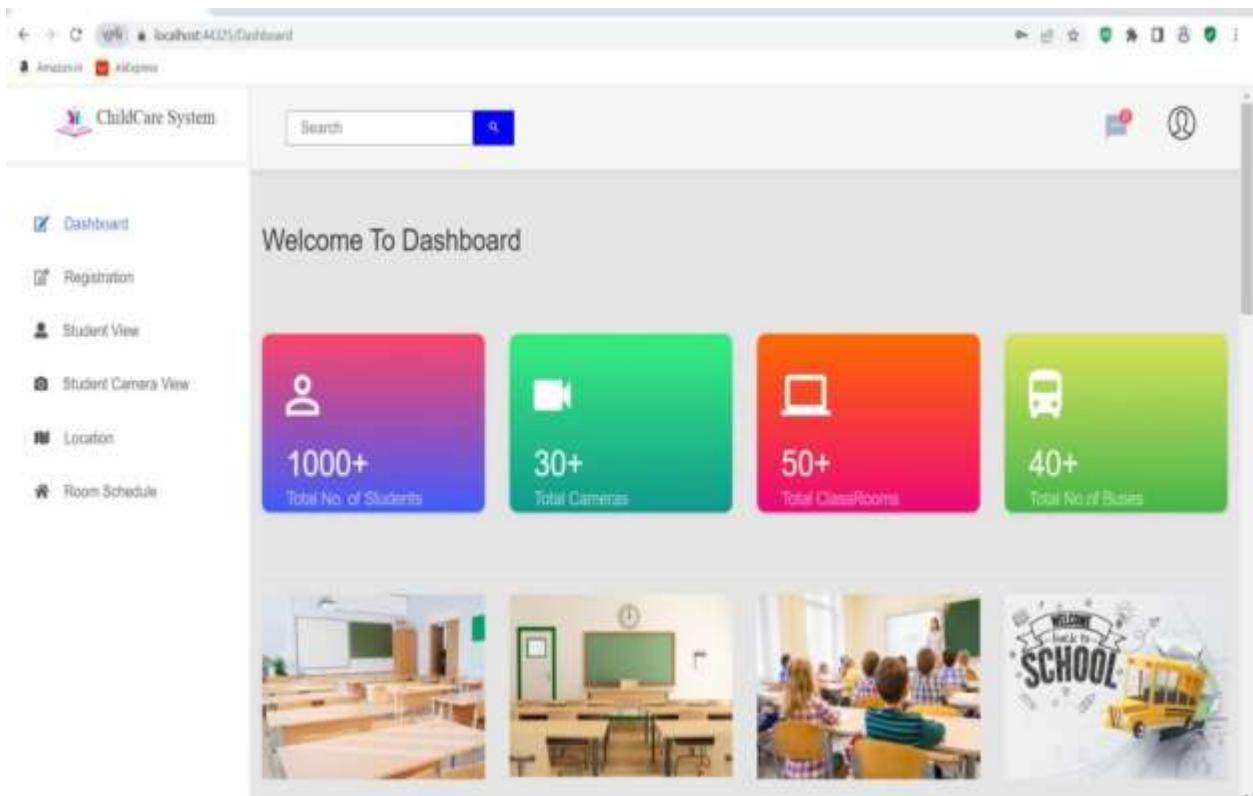

Figure 9: Admin Dashboard

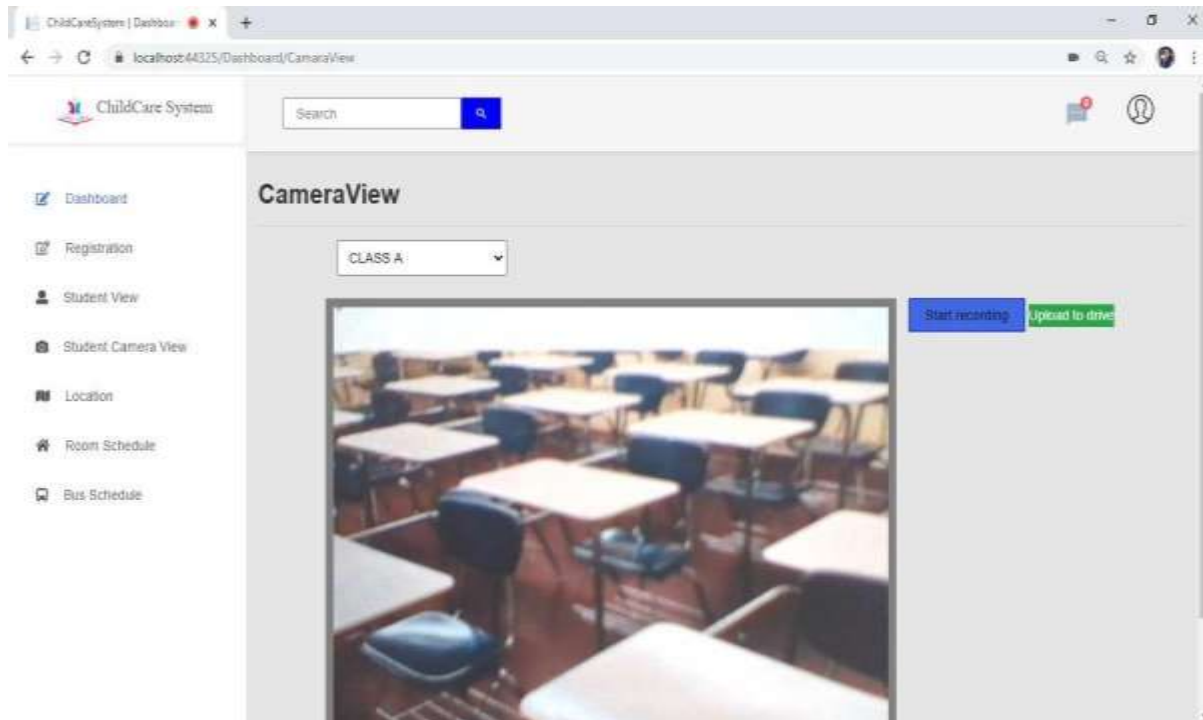

Figure10: Student Camera View

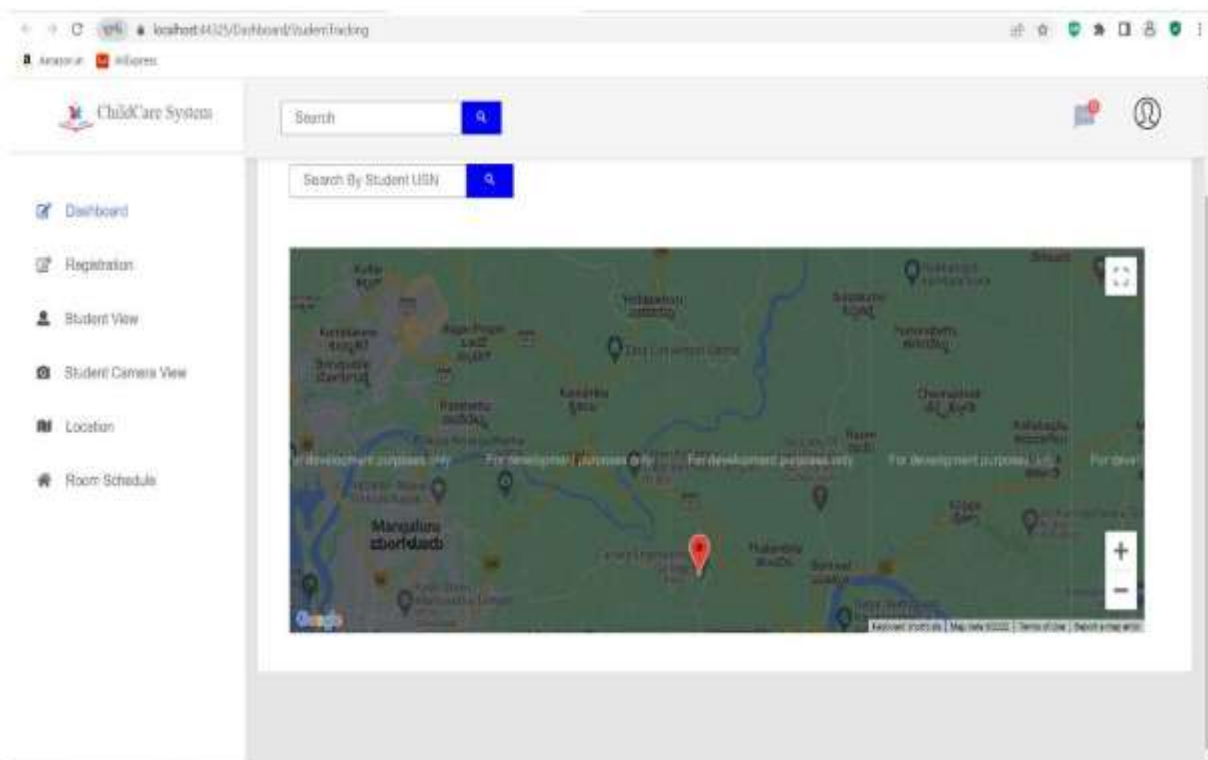

Figure11: Student Location

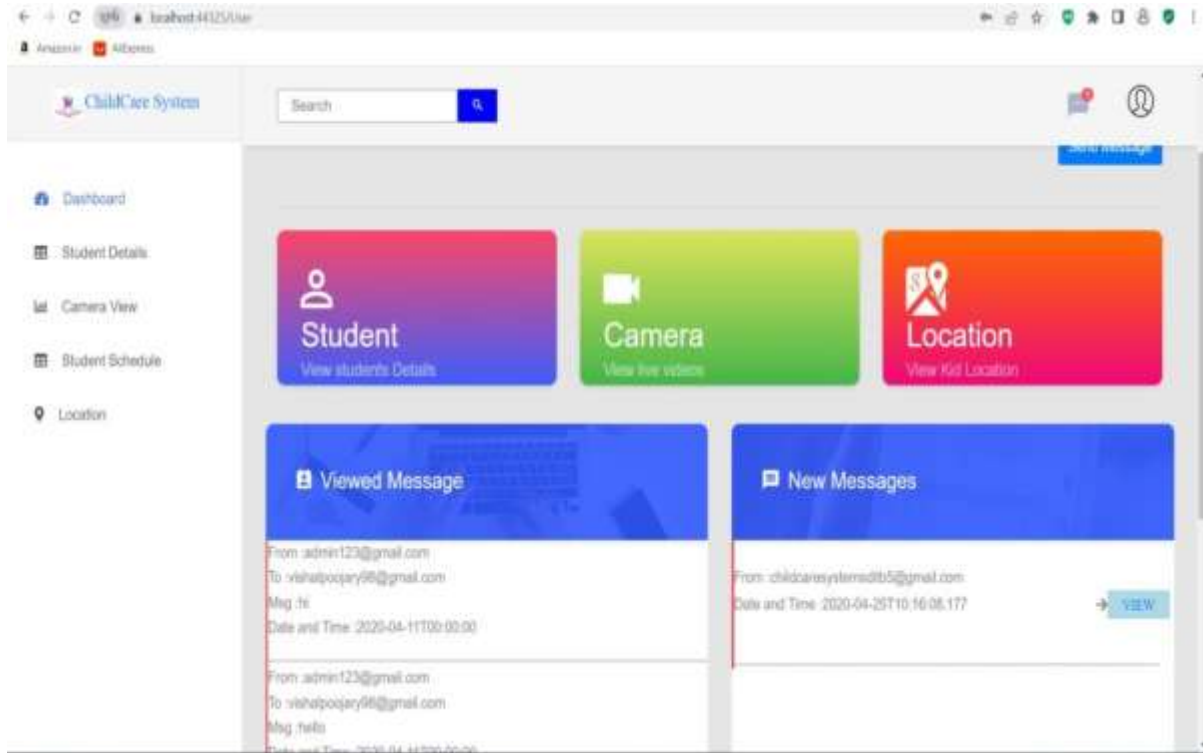

Figure12: Parent Dashboard

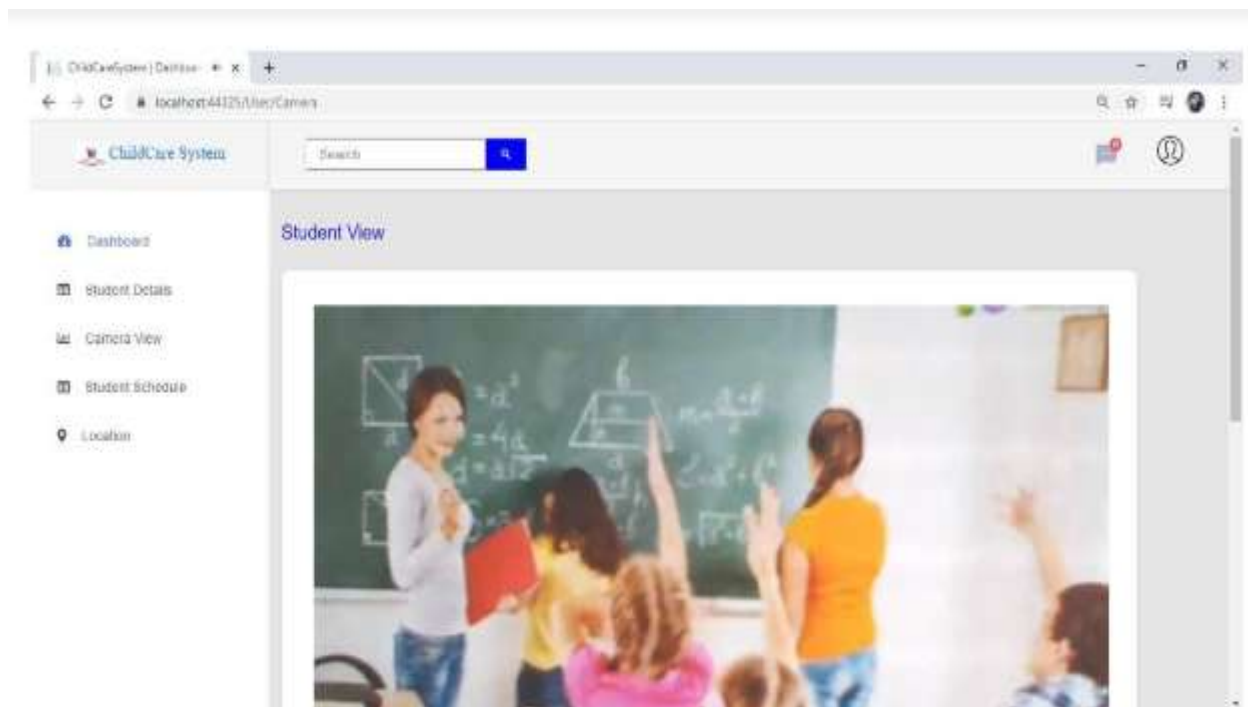

Figure13: Parent Camera View



Figure14: IOT device for Monitoring Child

VI. CONCLUSION AND FUTURE SCOPE

One of the applications of modern Information and Communication Technologies (ICT) in video monitoring is a GPS-based vulnerable Child Tracking System. The next era of smart child safety will be based entirely on Internet of Things (IoT) technology, which has revolutionized every aspect of everyday life by making everything smart and intelligent.

The system analyses children's activities with video enhancement and instant WEB/ANDROID app notification for better kid monitoring, according to the system. Atomization of the system with a cloud-based real-time database and precise sensors makes kid monitoring simple. This design concept is simple to apply and very flexible to meet the needs of the user. The integration of several sensors with live video monitoring will improve kid monitoring in the classroom or on the bus. The big issue of a missing kid may be remedied with the use of a child monitoring system. For parents who need to keep track of their children's every move, this system is essential.

VII. REFERENCES

- [1]. Kok Sun Wong, Wei Lun Ng, Jin Hui Chong, Chee Kyun Ng, AduwatiSali, Nor KamariahNoordin proposed the global position system (GPS) based child care system using RSSI Technique.
- [2]. Li Bing and Sun JianPing proposed Remote Video Monitoring System Based on Embedded Linux and GPRS.
- [3]. Mayur Bhor, Nikhil Kadam, Dinesh Shinde, Pranoti Mane proposed Children Safety and School Bus Tracking Solution.
- [4]. Jay Limbachiya, ApurvHarkhani, Nehil Jain, Suraj Gupta proposed IoT based School Bus Tracking System.
- [5]. Anwaar Al-Lawati, Shaikha Al-Jahdhami, Asma Al-Belushi, Dalal Al-Adawi, Medhat Awadalla and Dawood Al-Abri proposed the RFID-based System for School Childrens Transportation Safety Enhancement.
- [6]. V. Lavanya, C. Meenambigai, M. Suriyaa, S. Kavya, "Child Safety Wearable Device".
- [7]. Akash Moodbidri, Hamid Shahnasser, "Child safety wearable device," in IEEE Xplore, June 2017.
- [8]. Jatti, Anand & Kannan, Madhvi& M Alisha, R & Vijayalakshmi, P & Sinha, Shrestha.2016. Design and development of an IOT based wearable device for the safety and security of women and girl children.
- [9]. Child safety wearable device Gopinadh Jonnadula1, Bhanu Prasad Davu, Hari Kishore Kandula, Vinod Donepudi, sivaiahEtukuri Student of ECE, VVIT, Guntur, Andhra Pradesh, India. International Journal for Research in Applied Science & Engineering Technolgy (IJRASET). Volume 6 Issue II, February2018. Jay Limbachiya, ApurvHarkhani, Nehil Jain, Suraj Gupta proposed IoT based School Bus Tracking System.
- [10]. Shahid Bangali,S.K.Shah, "review: Real Time School Bus Security System with Biometrics, GPS and GPRS using ARM Controller" International Journal of Advanced Research in Electronics and Communication Engineering (IJARECE)Volume 4, Issue 4,PP 730732, April 2015.

IJEAST

INTERNATIONAL JOURNAL
OF ENGINEERING APPLIED SCIENCE
AND TECHNOLOGY

ABOUT IJEAST

International Journal of Engineering Applied Science and Technology (IJEAST) is a peer-reviewed, open access journal that publishes high-quality research papers in the field of Engineering, Applied Science and Technology.

IJEAST aims to provide a platform for researchers, academicians, and professionals to share their innovative ideas, research findings, and practical experiences with the global scientific community.

FOCUS AREAS

- Engineering
- Applied Science
- Technology
- Innovation & Development
- Interdisciplinary Studies



PEER REVIEWED

All submissions are rigorously peer reviewed to ensure quality.



OPEN ACCESS

Free and unrestricted access to research for all.



GLOBAL REACH

Connecting researchers and professionals worldwide.



TIMELY PUBLICATION

We ensure a swift and efficient publication process.



For more information, visit our website

www.ijeast.com



INTERNATIONAL JOURNAL
OF ENGINEERING APPLIED SCIENCE
AND TECHNOLOGY

✉ editor@ijeast.com

🌐 www.ijeast.com

📍 India



2455-2143