



IJEAST

INTERNATIONAL JOURNAL
OF ENGINEERING APPLIED SCIENCE
AND TECHNOLOGY



VOLUME : 6 ISSUE : 2 Print / Issue Publication Date: 25-Aug-2021



ISSN : 2455-2143



DOI : 10.33564/IJEAST.2021.v06i02.040

Indexed In



WWW.IJEAST.COM

editor@ijeast.com



EXPERIMENTAL TECHNIQUES

Anil Kumar Saxena
Ex. Scientific Officer, BARC
Raigad, Maharashtra, India,410210

Sanjay Limaye
Scientific Officer, BARC
Mumbai, Maharashtra, India,400085

P K Bhaumik
Ex. Scientific Officer, BARC
Mumbai, Maharashtra, India,400094

Abstract--There may be several aspects in any experiment conducted to achieve a well defined goal. It is considered more useful to cite number of experimental techniques employed in a single large scale experiment. For the rewetting of vertical cylindrical surface under bottom flooding conditions, it is reasonable to assume uniformity of temperature in the peripheral coordinate. Code RAMM (Rewetting Analysis using Moving Mesh) has been developed by the author of this paper [1] to calculate rewetting velocity. Experiments were also conducted for determination of rewetting velocities [2], the rewetting velocity in mm/s is 100.0 by [3]; 33.3 by [4]; 51.0 by [5]. This paper is aimed to cover experimental techniques employed in the determination of rewetting velocity (RV) in Nuclear Reactor Channel under the scenario of Loss Of Coolant Accident (LOCA). For determining RV, many experimental methodology and techniques were employed.

Experimental simulation of nuclear fuel pin clad named as fuel pin simulator, was carried out by taking hot vertical annular channel where rewetting of outer surface was studied. Experimental rewetting studies requires multi-disciplinary approach namely (i) selection of material for the fuel pin simulator. (ii) Installation of thermocouple wires at many locations into wall of a long and narrow tube (iii) Electrical resistance Joules heating of S. S. tube of 3.03m long, 0.015m outer and 0.012m inner diameters (iv) selection of power source for heating (v) Instrumentation required to capture parameters and (vi) Programming and connecting the Data Acquisition System (DAS) for recording the temperature transients.

Keywords — Rewetting, LOCA, DAS, Electrical resistance heating

I. INTRODUCTION

Special experimental techniques and methodology are required during handling of high temperature components of an experimental setup with a condition that they will be heated to high temperature and subsequently suddenly cooled. The techniques become more complicated when components are of relatively small sizes and various temperature profiles are required to be captured during heating and cooling cycles. Experimental techniques described in present paper are required for studying rewetting phenomenon needed to understand consequences and their mitigation during Loss of Coolant Accident (LOCA) in nuclear reactors having vertical channels. Description of entire experimental setup is out of scope of the paper. Portions where special experimental techniques are required will be discussed at length. However, brief description of experimental setup will be provided in next section to understand the experimental techniques more clearly.

II. DESCRIPTION OF EXPERIMENTAL SETUP

The setup consists mainly of a source of power supply, a source of demineralised water supply, a test section and a DAS. The description of the same is made available in [2]. The test section is comprised of inner stainless steel tube, outer stainless steel tube and copper tubes as a cold length of the heating inner tube. The copper tubes were brazed to the ends of the inner stainless steel tube at both the ends for connecting power source to the test section. Upper copper tube was clamped between two copper plates, each with a semicircular groove, with nut and bolt arrangement. Similarly lower copper tube was also clamped between two copper plates in order to achieve minimum contact resistance. Electrical cables from power supply unit were connected to the copper plates. Electrical resistance heating was



employed for heating the inner tube to the desired initial temperature using a low voltage high current variable AC power supply source. Chromel-Alumel thermocouples soldered to innertube were used to measure the temperatures. The demineralized water from a pressurized storage tank was fed in to the annulus formed by the concentric inner and outer tubes. The direction of flow of water can be selected either from bottom to top or from top to bottom depending on type of experiment. Water distributor was used to distribute the water in case of top flow rewetting, whereas no distributor was used for bottom flooding rewetting experiment.

The copper tubes were connected to a 10 V, 800 A A.C. power supply source using appropriate connectors which act as current conductors. The rest of the test section was electrically insulated from the current carrying inner tube including copper tubes by using fiberglass and asbestos gasket. At the lower end of the inner tube, a flange with 'O' ring seal was slipped on the copper tube to allow for thermal expansion/contraction of the inner tube when it is heated/cooled. The 'O' ring also serves as electrical insulation between the inner and outer tube. The outer tube of the test section was made up from three sections which were joined with the help of stainless steel flanges for easy installation and dismantling of the test sections.

III. DIFFERENT EXPERIMENTAL TECHNIQUES

The techniques are divided in following parts:

A. Fixing of thermocouples

Chromel-Alumel thermocouples soldered to inner tube were used to measure the temperatures. The size of chromel and alumel naked wires was 0.3 mm. They were insulated individually and both together with fiberglass insulation resulting in overall diameter of 1.2 mm. The diameter of thermocouple wires were chosen in order to achieve high response time as experiment involves capture of temperature transients. The thermocouples used in the present study have a response time of about 0.01 s. The thermocouple wires were brought out from inside of inner tube and connected to a junction box. The lead wires from junction box were connected to DAS.

For bottom flooding rewetting experiments, thermocouples were fixed at eight axial locations along the simulator from the bottom with equal axial

spacing of 400 mm between two adjacent locations. The thermocouples at these locations are designated as t1 to t8. The thermocouples t3a, t3b, t3c, t3d at third axial location were fixed around the circumference of the simulator. They were equally spaced at 90 degrees apart. Similarly the thermocouples t6a, t6b, t6c, t6d at sixth axial location were fixed around the circumference, spaced at 90 degrees on the simulator. The thermocouple t1 was fixed at a distance of 115 mm from the bottom of the simulator (which is of length 3030 mm). Similarly the topmost thermocouple was located at a distance of 115 mm from the top end of simulator. Thus the distance between the first and the last thermocouples is 2800 mm.

The following procedure was adopted for installation of thermocouples [6]. A typical thermocouple installation was shown in Fig. 1 'Y' shaped hole was drilled in the tube wall of simulator at the desired location. A dummy wire was inserted through this hole and pushed into tube till it comes out of the tube. The dummy wire was secured firmly with the thermocouple and was pulled back carefully through the hole till thermocouple wire comes out of the Y shaped hole. Then the dummy wire was detached from the thermocouple. Care was taken that the junction of the thermocouple remains flush with the surface of the simulator without any gap so that it can measure the surface temperature accurately. Silver solder was filled in the gap of Y shaped hole around the thermocouple junction. The surface was smoothened such that no projection appears on the surface. This was necessary because any projection will adversely affect the rewetting behaviour of the surface and any extra brazing material will adversely effect the measurement of temperature. The same procedure was followed to install the other thermocouples also. The thermocouple wires, taken out from the inner tube were connected to the junction box. The thermocouple leads from junction box were connected to DAS. The analog voltage output from thermocouples was converted to digital data in the DAS which were stored in a personal computer. Some thermocouples were also connected to a digital temperature indicator which provides a parallel means for the measurement of temperatures, particularly for monitoring temperatures during the heating of the test section.

Other applications of this technique are in geysers, digital temperature loggers, furnaces etc.

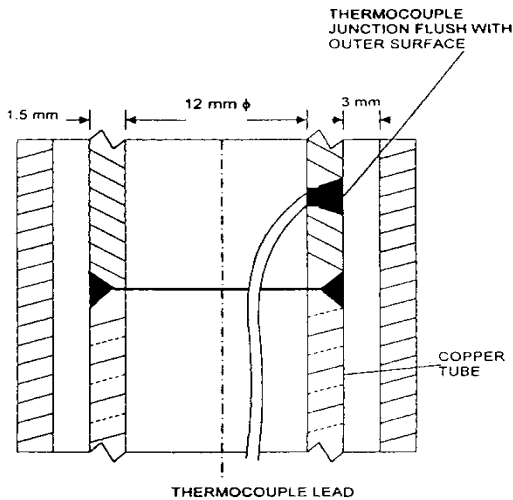

Fig.1 THERMOCOUPLE INSTALLATION DETAILS

B. Test for Installation of Thermocouples

The following procedure was adopted to ascertain whether the installed thermocouple would measure the correct surface temperature. A reference thermocouple was spot welded to the outer surface of simulator very close to an installed thermocouple which was to be tested. The simulator was heated and the temperature transients from both the thermocouples (reference and installed) were recorded through DAS during the heating of simulator and subsequent cooling. The typical temperature transients are shown in Fig. 2 and found to be very close to each other which ensures the proper installation of thermocouple and the surface temperature measurement. The testing of installed thermocouples was done whenever the change of inner tube was necessitated due to damage of simulator by repeated heating and cooling. The measured temperature transients of installed thermocouple and the reference thermocouple were always found to be close.

C. Heating of tube

The copper tubes, brazed to either end of simulator act as current conductors. Requirement of current is calculated using I^2R which is the power needed to the simulator. The resistance of simulator is measured by two methods (i) Experimental method ("Tinsley Resistance Bridge" and the "Constant Current with four terminal method") and (ii) Theoretical method. The copper tubes are connected to a 0-10 V, 800 A A. C. power supply source. The technique is further explained as follows.

C1. Electric resistance of the simulator is determined by the following method.

Resistance R of a conductor is given as

$$R = \frac{\rho_c L}{A}$$

Substituting specific resistivity of stainless steel ($\rho_c = 74 \times 10^{-8}$ ohm m), length ($L = 3.03$ m) and metal cross section area ($A = 63.585 \times 10^{-6}$ m²) of simulator, we get the resistance of simulator, $R = 0.0353$ ohm.

To cross check the theoretically calculated value of the resistance, experimental measurements were also carried out. Resistance of 1 m of simulator was measured to be 0.0117 ohms using a "Tinsley Resistance Bridge" and 0.0116 ohms based on the "Constant Current Method injection with four terminal method". The average of these values, 0.01165 ohms, was taken as the resistance of 1 m length of simulator. The resistance of 3.03 m of simulator is equal to 0.0352 ohms which is very close to the theoretical value. However this type of difference is expected due to manufacturing tolerance. For subsequent analysis 0.0352 ohms was used for the stainless steel portion of inner tube.

C2 Thermal power due to electric resistance heating in a conductor of resistance R is given by I^2R , where I is current flowing through conductor. The simulator was to be connected to a 0 - 20 Volts power supply. The maximum current, I that flows through the simulator is

$$I = 20/0.0352 = 568.2 \text{ A}$$

Other applications of electric resistance heating are electric heaters, electric furnaces, electric baseboard heaters, electric wall heaters, electric thermal storage etc.

D. Acquiring temperature time data

The purpose of DAS is to acquire the output of thermocouples and convert it to digital temperature data. This was done as follows:

The thermocouple wires from the simulator were terminated in a junction box. The thermocouple leads from the junction box were connected to the input signal conditioning card of DAS. The signal conditioning card consists of direct coupled differential high gain amplifier, filter and cold junction compensation circuit. Microvolt signals from thermocouples are amplified to volts. High



frequency noise, in amplified signal is filtered using low pass filter having cutoff frequency 2KHz. Acquired data are stored in a personnel computer. For data acquisition and storing, a computer program was used. The program has facility for varying the sampling period for data acquisition.

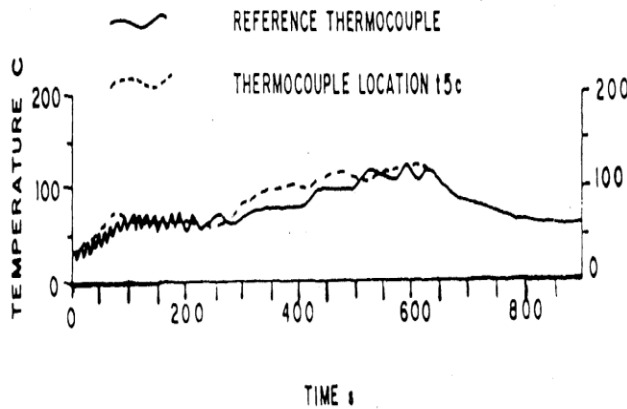

FIG 2 CHECK FOR THE CORRECTNESS OF THE THERMOCOUPLE INSTALLATION

The sampling period, i.e. the time interval between two successive temperature measurements is decided based on the storage capacity (equal to 23800 samples) of the DAS, number of thermocouple locations and the required time of data acquisition. Since we have 14 thermocouple locations in bottom flooding rewetting, 1700 samples can be acquired at each thermocouple location. The actual time of acquisition of temperature transients was in the range of 70 - 150 s which corresponds to a range of sampling period of 0.0411 - 0.088 s/sample in the present study. The time periods used in the present study are significantly small as compared to the expected range of time 1 - 37 s for the wet front to move between two successive thermocouple locations separating a distance of 400 mm. As the wet front moves to a thermocouple location, the temperature of that location decreases sharply. The response time of thermocouple is sufficiently small (0.01 s) to measure this instantaneous change in temperature. The time periods employed in present study are adequate to measure the instantaneous temperature as well as capable of tracing the sharpness of decrease in the temperature at the time of rewetting.

Data acquisition Software was based on “ASYST”, real time operating module for data acquisition [7]. Software offers hardware interfacing for PC based

Analog to Digital converter input output card. ASYST supports software synchronization concept that allows user to execute acquisition instructions at specific interval of time in milliseconds. This makes periodic sampling of analog data. Random access memory (RAM) drive concept was used to store 23800 samples. RAM drive offers fast storage of data. After end of acquisition, data is transferred to hard disk for further analysis. Fig-3 shows plots (rewetting transients) of the temperature verses time data acquired by the method mentioned above. t2, t3b, t4, t5, t7 and t8 are thermocouple locations respectively at distances mentioned in the figure from bottom of simulator. Fig-3 is an example for illustration. This is one out of large number of figures corresponding to various initial surface temperatures and cooling water flow rates.

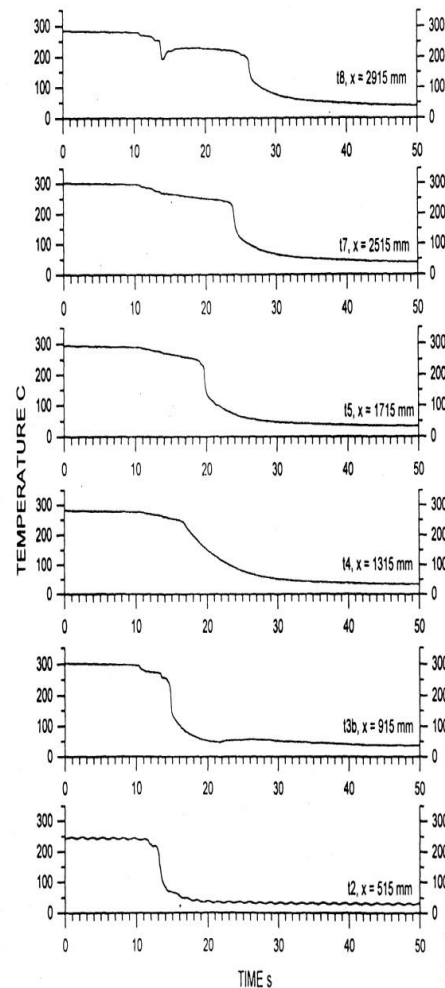

Fig 3. Experimental rewetting transients in bottom flooding rewetting. (Initial Surface Temperature =290 C, Cooling Water Flow Rate =5.9 (Litres/minute))



IV. SAFETY MEASURES FOLLOWED DURING EXPERIMENTAL TECHNIQUES

- (1) Electrical insulation by fiberglass is provided to have least possible interference of power supply on measurements.
- (2) Working personnel are provided protective gears as safeguards from electrical and thermal shock.
- (3) Experimental setup is provided thermal insulation by asbestos rope. Gasket is used to stop water/steam leak.

V. CONCLUSIONS

Experience of frequent installation of large number of thermocouples with high degree of perfection and providing the electrical insulation during heating is valuable and can be applied elsewhere also.

It is clear from Fig-3, that Data acquisition system & software was found to be very useful for generating large number of temperature verses time data for studying rewetting and other phenomenon.

VI. REFERENCES

- [1] Saxena, A. K. et. al. , (July – September 2008) Code RAMM for Rewetting on Vertical Nuclear Fuel clad, Indian Chemical Engineer, Vol. 50, No. 3.
- [2] Saxena AK, Venkat Raj V, and GovardhanaRao V. (2001). Experimental studies on rewetting of hot vertical annular channel, Nuclear Engg. and Design, 208, (pp283-303).
- [3] Bankoff, S. George and Afgan., N. H., Heat Transfer in Nuclear Reactor Safety, Mc. GrawHill,(1982).
- [4] Duffey, R. B. and Porthouse, D. T. C.,The Rewetting of Hot Surfaces by Falling Films and Bottom Flooding, RD/B/N 2530, (Jan.1973).
- [5] Barnea, Y., Elias, E. and Shai, I., Flow and Heat Transfer Regimes During Quenching of Hot Surfaces, Int. J. Heat Mass Transfer, 37,1441-1453,(1994).
- [6] Venkat Raj, V. (1985). Studies on the Rewetting of Hot Horizontal Surfaces, Ph.D. Thesis, I. I. T. Bombay.
- [7] ASYST 2.0 MODULE_3 (1987) ASYST Software Technologies Inc. 100 Corporate Woods, Rochester, NY 14623.

IJEAST

INTERNATIONAL JOURNAL
OF ENGINEERING APPLIED SCIENCE
AND TECHNOLOGY

ABOUT IJEAST

International Journal of Engineering Applied Science and Technology (IJEAST) is a peer-reviewed, open access journal that publishes high-quality research papers in the field of Engineering, Applied Science and Technology.

IJEAST aims to provide a platform for researchers, academicians, and professionals to share their innovative ideas, research findings, and practical experiences with the global scientific community.

FOCUS AREAS

- Engineering
- Applied Science
- Technology
- Innovation & Development
- Interdisciplinary Studies



PEER REVIEWED

All submissions are rigorously peer reviewed to ensure quality.



OPEN ACCESS

Free and unrestricted access to research for all.



GLOBAL REACH

Connecting researchers and professionals worldwide.



TIMELY PUBLICATION

We ensure a swift and efficient publication process.



For more information, visit our website
www.ijeast.com



INTERNATIONAL JOURNAL
OF ENGINEERING APPLIED SCIENCE
AND TECHNOLOGY

✉ editor@ijeast.com

🌐 www.ijeast.com

📍 India



2455-2143