



IJEAST

INTERNATIONAL JOURNAL
OF ENGINEERING APPLIED SCIENCE
AND TECHNOLOGY



VOLUME : 7 ISSUE : 01 Print / Issue Publication Date: 07-Jul-2022



ISSN : 2455-2143



DOI : 10.33564/IJEAST.2022.v07i01.036

Indexed In



WWW.IJEAST.COM

editor@ijeast.com



MODELING AND 3D PRINTING OF 2-WHEELER CHASSIS

Vamshi Eslavath, Goutham Diwan, Udaykiran Bairam
Department of Mechanical Engineering
Guru Nanak Institute of Technology
(Affiliated to Jawaharlal Nehru Technological University)

Abstract: 3D Printing or Additive manufacturing is a novel method of manufacturing parts directly from a digital model using a layer-by-layer material build-up approach. This tool-less manufacturing method can produce fully dense metallic parts in a short time, with high precision. Features of additive manufacturing like freedom of part design, part complexity, and light-weighting. The frame is an important part of a Two-Wheeler and it carries the load acting on the vehicle. So, it must be strong enough to resist the shock, twist, vibration, and other stresses. Stainless Steel material is used for printing chassis. The Modeling of the 2-wheeler chassis for the bike is done using CATIA V5 software and Metal 3D printing of the chassis is performed using EBAM (Electronic beam addition manufacturing) method.

Keywords: catia v5, chassis, stainless steel, ebam.

I. INTRODUCTION

The motorcycle chassis consists of the frame, suspension, wheels, and brakes. Each of these components is described briefly below. Frame Motorcycles have steel, aluminum, or an alloy frame. The frame consists mostly of hollow tubes and serves as a skeleton on which components like the gearbox and engine are mounted.

The frame also serves as a support for the suspension system, a collection of springs and shock absorbers helps keep the wheels in contact with the road and cushion the rider from bumps and jolts. Wheels Motorcycle wheels are generally aluminum or steel rims with spokes, although some models introduced in the 1970s offer cast wheels. Cast wheels allow the bikes to use tubeless tires, which, unlike traditional pneumatic tires, don't have an inner tube to hold the compressed air. The front and rear wheel on a motorcycle each have a brake. The rider activates the front brake with a hand lever On the right grip, the rear brake with the right foot pedal. Drum brakes were common until the 1970s, but most motorcycles today rely on the superior performance of disc brakes.

The frame is that element of the bike that deserves the highest importance since it is the base or foundation. Without proper design and engineering precision

implemented before the manufacturing of the frame, it can result in a total failure of the bike.

Different Types of Motorcycle Chassis

1. Backbone Chassis

The backbone frame is shaped like a spine and holds important bike parts in place, and the engine is attached to the frame. The amount of product used to make this is lesser than other frame types, making it very cost-effective. Even though the backbone frame's production is inexpensive and comfortable, it is not the first choice for many as it lacks strength and torsional rigidity. It is the cheapest type of motorcycle chassis.

2. Single Cradle Chassis

A single cradle frame or single down tube frame resembles the framework of a bicycle. It has a unique steel tube that goes down to support the engine for a single cradle chassis. It also has a simple and cost-effective structure. It comprises steel tubes welded together to form a structure that holds the various components of the motorcycle. In some cases, the engine is attached to the chassis and works with it, bearing some of the stress. A single cradle chassis, in most cases, would mention whether the engine is a stressed member of the frame or not.

3. Double Cradle chassis

A Double Cradle or a double down tube chassis frame has got two tubes going down that cradle it. A Double Cradle chassis is better than its single down tube counterparts in terms of strength and rigidity, though there is no evident difference in cost. While this type of frame is the most common choice in India due to its sturdiness and cost-effectiveness, it is not the best performance-wise and has an outdated design.

4. Perimeter Chassis

The perimeter frame, also known as the Twin Spar frame, is one of the most popular choices among performance sports bikes due to its suitability for high-performance motorcycle applications. This type of motorcycle chassis reduces rigidity as its steering head joins the swing arm in the shortest distance possible. The beams entering the steering



head with the swing-arm are stiff, light, and surround the engine. Earlier, these were made of steel; now, almost all modern perimeter frames are made of lightweight aluminum.

Forces acting on Chassis

- **Weights of all the Components and Riders:** The frame supports all the major components of the vehicle systems such as the power train, suspension, and other accessories as well as the riders and the excess payload they carry. Thus, the frame accounts for all the forces acting on it due to their weights in the downward direction
- **Bump Force:** When the vehicle undergoes a ground disturbance in the form of a bump or a hole a force is exerted on the frame. For design considerations, it is assumed that the rear suspension mono-shock and the front telescopic fork suspension have attained full travel which is 3 inches.
- **Lateral Force due to Turning:** Lateral force or side force is the cornering force produced by a vehicle wheel during cornering. It is equivalent to the centrifugal force generated due to cornering. Inertia causes load transfer in a lateral direction; i.e., the load from the right side is transferred to the left side while taking a right turn and vice versa.
- **Brake Force due to Torque required for Braking:** Brake force is generated on the frame at the front collar where the steering handlebar is mounted and the metal plate where the wheel is connected using the swing arm when the brake is applied to retard the motion of the vehicle. It is calculated as the product of the pressure generated in the fluid line with net the area of the caliper piston and the coefficient of friction between the brake pads and the brake disc.
- **Longitudinal Weight Transfer:** During acceleration and braking, the inertia of the vehicle components causes load transfer in the longitudinal direction of the vehicle; i.e., from the rear is transferred to the front while braking, and the opposite effect takes place while accelerating. This load transfer (or weight transfer) exerts a force on the frame. A similar effect takes place while negotiating a corner.
- **Force on Impact:** When the vehicle is subjected to a front, rear or side impact an impulse force is exerted on the frame. This force may lead to excessive stress on the frame causing deformation.

II. MODELING

CATIA V5 (Computer-Aided Three-Dimensional Interactive Application). As a new user of this software package, you will join hands with thousands of users of this high-end CAD/CAM/CAE tool worldwide. If you are already familiar with the previous releases, you can upgrade your

designing skills with the tremendous improvement in this latest release.

CATIA V5, developed by Dassault Systems, France, is a completely re-engineered, next-generation family of CAD/CAM/CAE software solutions for Product Lifecycle Management. Through its exceptionally easy-to-use and state-of-the-art user interface, CATIA V5 delivers innovative technologies for maximum productivity and creativity, from the inception concept to the final product. CATIA V5 reduces the learning curve, as it allows the flexibility of using feature-based and parametric designs.

CATIA V5 provides three basic platforms: P1, P2, and P3. P1 is for small and medium-sized process-oriented companies that wish to grow toward the large-scale digitized product definition. P2 is for the advanced design engineering companies that require the product, process, and resource modeling. P3 is for the high-end design applications and is basically for the Automotive and Aerospace Industry where high-quality surfacing or Class-A surfacing is used.

The subject of interoperability offered by CATIA V5 includes receiving legacy data from the other CAD systems and its own product data management modules. The real benefit is that the links remain associative. As a result, any change made to this external data gets notified and the model can be updated quickly.

CATIA V5 serves the basic design tasks by providing different workbenches. A workbench is defined as a specified environment consisting of a set of tools that allows the user to perform specific design tasks. The basic workbenches in CATIA V5 are

- Part Design
- Wireframe and Surface Design
- Assembly Design
- Drafting, Generative Sheet metal Design

Modeling of 2-Wheeler Chassis

We have divided the chassis into 3 parts Moving joint, Rod, and Chassis. After modeling, we assembled those parts in Assembly Design

- By using the pad, pocket, and mirror command, the moving part of the chassis is designed.
- Using the pad command, the rod is designed.
- The other commands used to design the chassis are Rib, shell, stamp, and mirror.

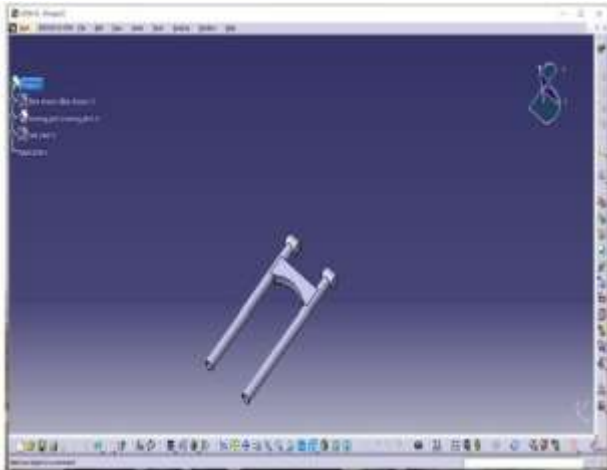

Moving Joint

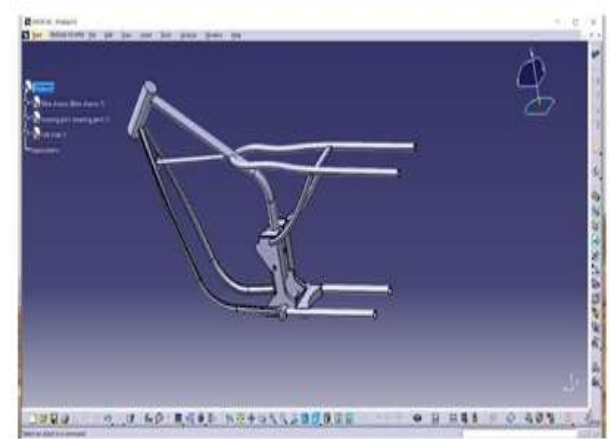

Assembled parts DIMENSIONS: 1195 x 816 x 310 mm

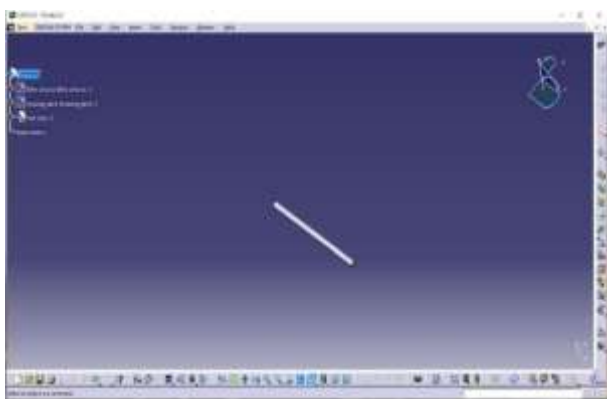

Rod

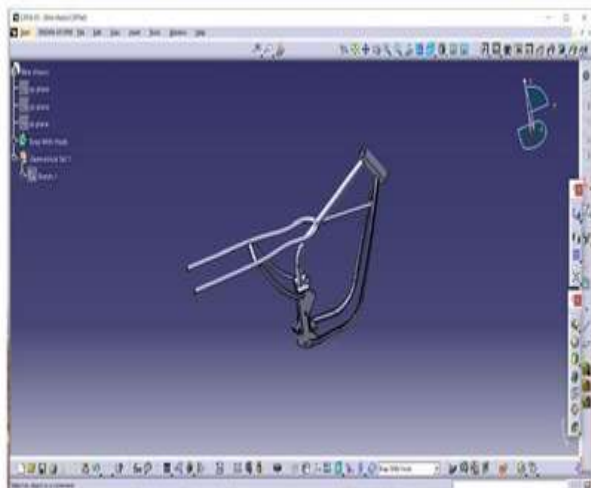

Chassis

III. 3D PRINTING

Additive Manufacturing or 3D printing (commonly called) is a process that creates a physical object from a digital design. There are different 3D printing technologies and materials you can print with, but all are based on the same principle: a digital model is turned into a solid three-dimensional physical object by adding material layer by layer.

It is important to point out from the beginning that Additive Manufacturing does not constitute a single technology but a set of manufacturing processes, very different from each other, that share three common characteristics

They are manufacturing processes by the addition of material to construct a solid three-dimensional object. The object is constructed by superimposing successive layers of material.

The object is made from a digital 3D model. They are called ADDITIVE manufacturing processes to differentiate them from conventional processes. Together with these, they are part of the set of processes available to the industry. Some of the most used additive manufacturing technologies that best suit the educational area will be described in the following point of this guide.

These technologies are Fused Deposition Modeling (FDM), Stereolithographic (SLA) and Selective Laser Sintering (SLS), and Electron Beam Addition manufacturing (EBAM).

Working On 3D printing

It all starts with making or obtaining a virtual design of the object you want to create. This virtual design can be made in a CAD (Computer-Aided Design) file using a 3D modeling program (for the creation of a new object) or with the use of a 3D scanner (to copy an existing object). A 3D scanner makes a 3D digital copy of an object. There are also lots of online file repositories where you can download existing 3D files that will help get you started. The 3D printing process turns an object into many, tiny little slices, then builds it from the bottom up, slice by slice. The layers then build up to form a solid object

Electron Beam Addition manufacturing (EBAM)

The principle is very similar to that of a scanning electron microscope. A heated tungsten filament, in the upper column, emits electrons which are collimated and accelerated to the kinetic energy of about 60 keV. The electron beam is controlled by two magnetic coils, which are housed in the lower column. The first one is a magnetic lens that focuses the beam to the desired diameter, and the second one deflects the focused beam to the desired point on a build platform. The electron-beam gun itself is fixed; no moving mechanical parts are involved in beam deflections. The beam current is controlled in the range of 1–50 mm and the beam diameter can be focused down to about 0.1 mm. In the chamber of the middle part of the machine, fine metal powder, on the order of 10–100 μm , is supplied from two hoppers and forms a thin layer by a raking mechanism before each layer is built. The typical layer thickness is in the range of 0.05–0.2 mm. The computer-controlled electron beam scans over the powder layer in a predefined pattern and consolidates the desired areas into solid and dense metals. The beam has to first scan at a high speed (order of 10 m/s) in multiple passes to preheat powder to a sintered state, while a beam scan on the order of ~ 0.5 is used during the melting cycle. Then, a new powder layer is laid on top and the scanning process is repeated until all layers are completed.

The entire process takes place under a high vacuum. The typical pressure of residual gases in an EBAM machine is 10^{-1} Pa in the vacuum chamber and 10^3 Pa in the electron gun. During the melting process, low pressure of inert helium gas (10^{-1} Pa) is added to the vacuum chamber to avoid the build-up of electrical charges in powder. When all layers have been completed, the built part is allowed to cool inside the process chamber, which is then filled up with helium to assist in cooling. Because of radiation from electrons, the process observation is not as accessible as other AM technologies, only through a leaded-glass viewport. Therefore, what exactly happens inside the build chamber is not as well perceived as other AM processes. Recently, Oak Ridge National Laboratory published a video animation of the EBAM process that offers good illustrations of the process details, especially to those without access to an EBAM machine.

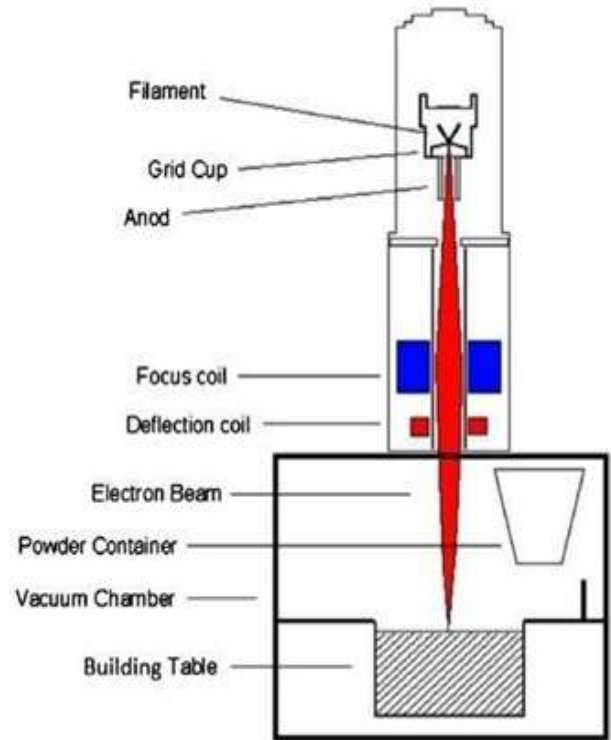

Schematics of EBAM

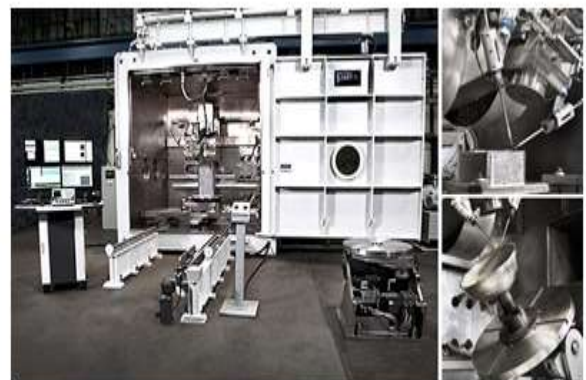



Printing of Material

3DXpert is the All-in-One Software Solution for Metal Additive Manufacturing. It has all the tools to prepare your part for printing and send it to your printer. The 3DXpert 3D Printing complete work flow goes from data import through design to post-printing operations. 3DXpert brings a new era of part preparation for 3D printing. It allows you to seamlessly work with both B-rep (boundary representation, meaning solid or surfaces) and mesh triangulation formats (e.g., STL). This capability of 3DXpert eliminates the need to convert solid or surface data into the mesh and improves data quality and integrity. Working in any format, you can save valuable time, and have greater flexibility to make changes to the model at any stage of the process, using history-based parametric CAD tools. 3DXpert is a single, integrated solution that covers the entire metal additive manufacturing process. There is no longer a need for several different solutions to get the job done. 3DXpert offers everything you need – importing part data, optimizing the geometry and lattice creation, calculating the scan path, arranging the build platform, sending it to the printer, and even machining the final product when necessary – all in a single software solution. 3DXpert provides the ideal mix of tools for automating repetitive tasks while allowing you to control every parameter and aspect of the entire design and manufacturing process. Get the most out of your printer using pre-defined best practice parameters for each printer, material, and print strategy, or develop your printing strategies with unprecedented control over scan-path calculation methods and parameters.

- Importing Data
- Position geometry
- Optimize structure
- Design support
- Stimulate build
- Optimize printing strategies
- Calculate scan path
- Arrange build platform & print
- Testing, Orientation, Distribution and Assign G-Codes

Now the G-Code has been obtained the process of 3D printing can be implemented. There are a few things to consider and check before printing of piston. For EBAM printers, the temperatures of the bed or printing platform and the extruder must be checked (the software or the printer does that automatically when you start to print). Using some kind of lacquer or varnish is also recommendable to ease the extraction of the chassis. It is advisable to read the instructions to also know how to load the filament on the printer. Therefore, the G-Code is sent to the machine, and the machine starts to work.

Metal Material Extrusion

This technology was specifically created to make metal 3D printing cheaper and more accessible and it's done just that. Small and medium businesses have rapidly adopted material extrusion with metal, largely because it's so affordable. Design studios, machine shops, and small manufacturers use metal material extrusion machines to iterate designs, create jigs and fixtures, and complete small production runs. The latest development in this space is metal filaments that will work in most desktop FDM 3D printers, making metal 3D printing accessible to nearly everyone.

This is how material extrusion with metal works:

- Either polymer filament or rods impregnated with small metallic particles are 3D printed layer-by-layer in the shape of your design.
- The 3D printed part is then washed to remove some of the binders.
- The part is then put in a sintering furnace which fuses the metallic particles into solid metal.

Post-processing

Like many 3D printing processes, support structure removal is required on DMLS parts. Typically, parts are first removed from the build plate using wire EDM or a band saw, and then support structure material is removed with hand tools. That works well in many cases, but sometimes additional machining option can be necessary for critical features that require tighter tolerances or improved surface finishes.

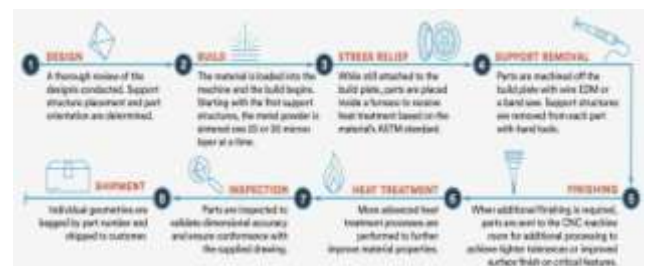

Post-process machining can also be used to improve surface finish quality. As-built surface finish roughness on DMLS parts can range from 3µm to 12µm Ra depending on orientation, material, and layer thickness. Through post-process CNC machining, a surface finish of Ra 0,8µm is possible.

Printing Materials

Today, the 3D printing market offers a variety of choices for what concerns materials. From polymers and metals to ceramics and composites, many are the materials that have been created, each of them with its advantage and disadvantages. Some examples are visible on 3dhubs.com, a portal that provides 3D printing services on a global level.

- Prototyping Plastic, suitable for fast and cost-effective prototyping;

- High Detail Resin, suitable for intricate designs and sculptures;
- SLS Nylon, for functional prototypes and end-useparts;
- Fiber-Reinforced Nylon, for engineering strongparts;
- Rigid Opaque Plastic, for realistic prototypes with high accuracy;
- Rubber-Like Plastic, simulating rubber;
- Transparent Plastic, to create see-through parts and prototypes;
- Simulated ABS, with high precision and functional molds;
- Full Color Sandstone, for photo-realistic models;
- Industrial Metals, for prototypes and end-use parts.

The industry's offer is, of course, much wider than what is reported here. For what concerns the demand instead, here the use of a certain material is strongly influenced by not just the type of technology adopted, but also the popularity of 3D printing machines.

Limitations of Printed Objects

- Initial investment: Desktop FDM printers are usually cheap, but for other technologies, especially if larger machine sizes are sought, the initial investment can be very high.
- Size of the pieces: The size of the pieces to produce depends on the printing bed. While it is true that many large pieces can be chopped and then joined.
- Non-profitable mass production: Additive manufacturing and 3D printing are designed for a very short series of pieces (around 1 - 10 units). For longer series, production with these technologies is not profitable.
- Finishes and precision: In general, getting a very good finish and very good precision will be expensive. That is to say, it will be necessary to resort to more expensive technologies and machines. In addition, the parts may require post-processes, other machines, and special sub-processes.
- Obtaining digital files: If specific and highly customized pieces are desired, it is necessary to possess advanced CAD design knowledge. Most of the time, the repositories of CAD files are not enough. The same goes for the 3D scanner; they are expensive and using them requires certain knowledge

Printing 3-D Model

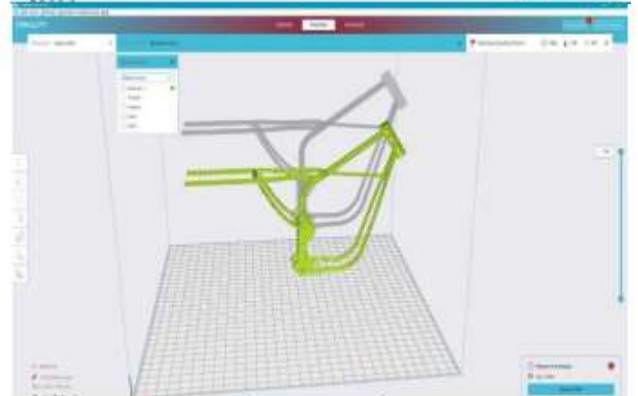
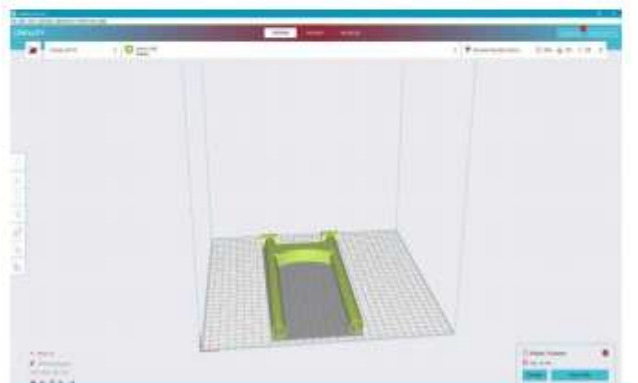

Orientation and slicing of the 3-D model are performed using 3DXpert software.

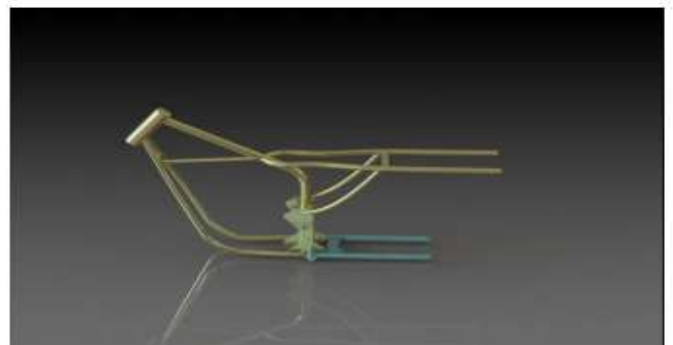

Final Product



IV. RESULT

Modeling of 2-wheeler chassis is done using CATIA V5 software in part design, 3 parts of 2-wheeler chassis are designed. Later these 3 parts are assembled in assembly design. The model is converted into STL file format and imported into the software, Orientation, and slicing of the 3-D model are performed using 3DXpert software. G-codes are assigned to print the 2-wheeler chassis in EBAM-300 machine. Finally, the 3D model of the 2-wheeler chassis is obtained by EBAM (Electron Beam Additive Manufacturing) method

V. SCOPE OF FUTURE WORK

There is good scope for 3D Metal printing of 2-wheeler chassis because of its benefits over the conventional machining process. Many companies may use this technology for the production of two-wheeler chassis in the future as it generates less wastage. As this manufacturing process is environmentally friendly and commercially very profitable, companies will utilize this 3D printing technology. This project can be further developed by changing the material used in the printing of the 2-wheeler chassis and by giving different dimensions to the 2-wheeler chassis in the modeling of the chassis.

VI. ACKNOWLEDGMENT

We express our deepest sense of gratitude to our guide **Ms. B. SHUSHMA**, Assistant Professor, Department of Mechanical Engineering, GNIT, Hyderabad, for their support to finish this paper.

VII. REFERENCES

- [1] J.A. McGeough, 1998, *Advanced Methods of Machining*. London: Chapman and Hall.
- [2] M. Kunieda, B. Lauwers, K.P. Rajurkar, B.M Schumacher, 2005, *Advancing EDM through Fundamental Insight into the Process*, CIRP Annals - Manufacturing Technology, vol. 54 (2),pg. 64-87.
- [3] Norliana Mohd. Abbas, Darius G. Solomon, Md. Fuad Bahari, 2006, *EDM: Global Techniques and Local Scenario*, 1st International Conference & 7 the AUN/SEED-Net Fieldwise Seminar on Manufacturing and Material Processing (ICMM2006), Kuala Lumpur, 14-15 March 2006, pg 71-76.
- [4] W. Rehbein, H.P. Schulze, K. Mecke, G. Wollenberg, M. Storr, 2004, *Influence of Selected Groups of Additives on Breakdown in EDM Sinking*, Journal of Materials Processing Technology, vol. 149, pp. 58-64.
- [5] Serope Kalpakjian, Steven Schmid, 2006, *Manufacturing Engineering and Technology*, Fifth Edition, Prentice-Hall, Singapore.

- [6] Federation of Malaysian Manufacturer [www.fmm.org.my on 25 January 2010]
- [7] Sabbadini S, Tassa O, Gennaro P, Ackelid U. Additive manufacturing of gamma titanium aluminide parts by electron beam melting. In: Proc. TMS 2010— 139th annual meeting and exhibition, February 14, 2010—February 18, 2010, Minerals, Metals and Materials Society, 2010, p. 267-74.
- [8] Jamshidinia M, Kong F, Kovacevic R. The coupled CFD- FEM model of electron beam melting (EBM). Mechanical Engineering Research, Paper 4. 2013.
- [9] Gong X, Anderson T, Chou K. Review on powder-based electron beam additive manufacturing technology. In: ASME/ISCIE 2012 international symposium on flexible automation. St. Louis, MO, June 18-20, 2012, ISFA2012-7256.2012.
- [10] Yu P, Qian M, Tomus D, Brice CA, Schaffer GB, Muddle BC. Electron beam processing of aluminum alloys. In: Proc materials science forum, Trans Tech Publ, 2009, p. 621-626.
- [11] Cormier D, Harrysson O, West H. Characterization of H13 steel produced via electron beam melting. In: Proc. selected papers from the 14th annual solid freeform fabrications symposium, University of Texas, Austin, Texas, 4-6 August 2003, Emerald Group Publishing Ltd., 2003, p. 35-41

IJEAST

INTERNATIONAL JOURNAL
OF ENGINEERING APPLIED SCIENCE
AND TECHNOLOGY

ABOUT IJEAST

International Journal of Engineering Applied Science and Technology (IJEAST) is a peer-reviewed, open access journal that publishes high-quality research papers in the field of Engineering, Applied Science and Technology.

IJEAST aims to provide a platform for researchers, academicians, and professionals to share their innovative ideas, research findings, and practical experiences with the global scientific community.

FOCUS AREAS

- Engineering
- Applied Science
- Technology
- Innovation & Development
- Interdisciplinary Studies



PEER REVIEWED

All submissions are rigorously peer reviewed to ensure quality.



OPEN ACCESS

Free and unrestricted access to research for all.



GLOBAL REACH

Connecting researchers and professionals worldwide.



TIMELY PUBLICATION

We ensure a swift and efficient publication process.



For more information, visit our website

www.ijeast.com



INTERNATIONAL JOURNAL
OF ENGINEERING APPLIED SCIENCE
AND TECHNOLOGY

✉ editor@ijeast.com

🌐 www.ijeast.com

📍 India



2455-2143