



IJEAST

INTERNATIONAL JOURNAL
OF ENGINEERING APPLIED SCIENCE
AND TECHNOLOGY



VOLUME : 7 ISSUE : 02 Print / Issue Publication Date: 05-Aug-2022



ISSN : 2455-2143



DOI : 10.33564/IJEAST.2022.v07i02.037

Indexed In



WWW.IJEAST.COM

editor@ijeast.com

“I-HELMET”: WAY TO IMPROVE TYPICAL MINERS’ SAFETY

Gamlath.G.R.G.K, Silva.A.H.D.M, Balasuriya..D.A.M, R.P.S.C.Rajapaksha, Dr.Anuradha Jayakody
Department of Information Technology
Sri Lanka Institute of Information Technology
Malabe, Sri Lanka.

Abstract— Safety of life is the main challenge for all miners in the world today. Mining is one of the most dangerous activities in the world. The highest number of occupational deaths occurs in the mining industry. The safety of the miners in the mining industry is very important. Miners usually wear only a helmet with light for visibility. In some cases, it is difficult to identify the miner & #39; s health after an accident and give some advice about the miner’s health. Their life safety is at a very low level. So, we can reduce the risk of mining and improve efficiency. The system we propose in this research not only focuses on miners’ safety in the inside of the mine. In this research, we also focus on IoT applications. Using this application, we can get medical advice from doctors (Telemedicine) and can inform to the emergency unit. Also, this system has a gas detection system and Image processing to the environmental condition in mine and human through the accidents. The aim of this research is to create a software & #amp; hardware solution that provides a completely safe and automated experience for miners inside a mining site. It can be implemented in real-time and is expected to be implemented under general specifications for mining systems in the future.

Keywords— Image Processing, IoT, Telemedicine, CNN, RF Technology

I. INTRODUCTION

According to researchers, mining is a major source of foreign exchange for the economies of developing countries such as India, Argentina, Armenia and Sri Lanka. The main theme of the project is to save the lives of miners as a large number of people die annually due to these mining related accidents. The highest occupational mortality rate occurs in the mining industry [1]. To enhance the safety of this proposed new system, the system has a gas detection sensor for detecting toxic gases and a camera module for this helmet system to detect environmental conditions. Using it, we can identify people and objects at risk [7]. The new method for detecting and measuring a miner’s health involves the use of pulse rate and miner’s body temperature. Also, the system has an app to notify the

emergency unit and connect with doctors through the app. Furthermore, the main control unit can receive warnings from miners via the I-helmet.

In addition, the researcher has carried out a process to identify the amount of dust in the mine, which tests the dust in the area where the miner is located [13]. The data obtained by this device is updated to a cloud space. Sensors used in our specialized system can detect miners’s heart rate, body temperature, and body (blood) oxygen levels. These components can measure increased productivity. Health sensors in this new system will alert miners and dashboards if the pulse rate is high. Body temperature can be measured by a sensor used to measure the temperature of our new system.

The specialty here is to check the humidity and it is advisable to drink water according to the temperature. This will remind you every 30 meters (according to temperature data). The Telemedicine web app can be used to check the health of the miner. This is because in case of any ill health, the miner can rest as instructed. Then during this period, the main control unit can get medical recommendations from the doctor. This technology makes this newly designed helmet even more unique. It is also very difficult to send data wirelessly from the mines to the ground surface to the main control center. If cables are used, it is also an expensive task. Therefore, RF technology is used to send data from the I- Helmet to the main control center.



Fig. 1. The I-Helmet Device

II. METHODOLOGY

The activities of this innovative project are divided into three phases. The first step is to use the C++ and python languages for programming using the Arduino IDE software. As a second step, the program code Arduino Mega 2560 uploads all the variables needed to upload to the Raspberry pi, translates it and sends it to the PIC to express the input and output. The IDE analyzes all the code before uploading it to the sensor and sends it to the sensor only if all the code is correct. All data from these sensors is uploaded to the main database via the HC-12 module (RF). According to researchers, Ubidots Server, a connected database management system, stores data in its web applications. The application provides tools for crash monitoring, analysis, reporting and repair, as well as marketing experience and product [9]. Here mqtt server sends Ubidots to the application via the API. This allows physicians and the emergency unit to be contacted by the main control unit.'

A. Environmental exploration and accident identification at the mining site with data visualization

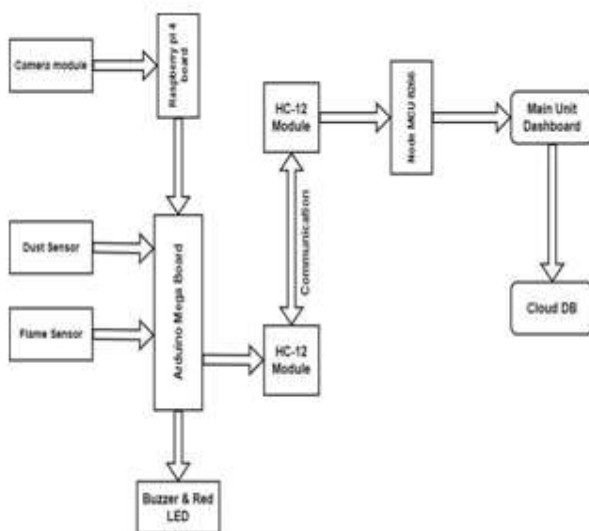

Fig. 2. Environmental exploration and accident identification

In order to implement this new smart helmet concept, an emergency database must be found to develop the image processing model needed to identify worker accident at the mining site. Obtaining such datasets is a difficult task. Here you have to go to a mine to get the pictures you want for the database and engage in a process of artificially retrieving the data you need.

To train this data, Tensor Flow uses the in-depth learning object recognition model training methodology. The algorithm used for this is the Prediction Algorithm. This is

first labeled to get the danger spots in the pictures. For this they used Cascade-Trainer-GUI software. It detects positive and negative data and obtains accurate images needed to identify accident. This Tensor Flow model takes a long time to operate on a normal computer. Google colab was used as a solution. It does not take much time and has the ability to train the model very quickly.

It then connects the dataset obtained to the model obtained in this learning method and converts it into Tensor Flow lite. This is because there is no additional cost to process the data once it is inserted into the main motherboard. Accidents are then detected through the camera system and reported to the Chief Controller.

In addition, it is intended to use a dust sensor to detect the amount of dust in the mine. This is because the heavy dust that is common in mines has the potential to severely affect human internal systems.

B. Explore and identify the physical structure of the mining site, its safety and hazards

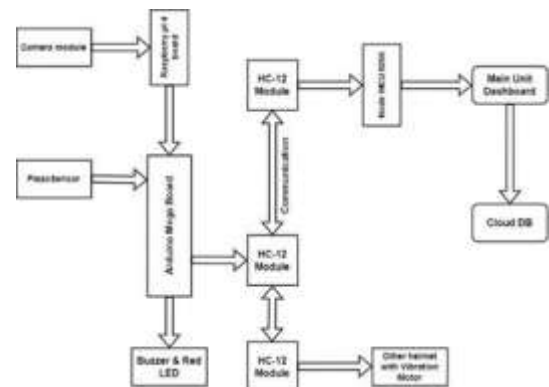

Fig. 3. Explore and identify the physical structure

The pressure sensor and the camera module are mainly used here. Ground pressure level and mine collapse can be detected using a pressure sensor. If any load falls on the miner's head, it is detected by a pressure sensor. Using the camera module, you can get a physical structure in a clear location. It can also identify damaged areas in the interior of the mine and soil structures in excavation areas as well as wet areas.

The associated pressure sensor detects mine crashes and alerts the miner to all helmet vibrations connected to the system and to the main board. In such a case the Emergency Vehicles and Fire Unit will be notified by SMS. The associated camera module facilitates the detection of land mines, wetlands and subsoil, striped ground, and cracked walls. It alerts the main control panel of early signals about mining structures. This research component will consider image processing, IoT, networking and algorithms.

C. Exploration and identification of ambient air quality and informing the end user

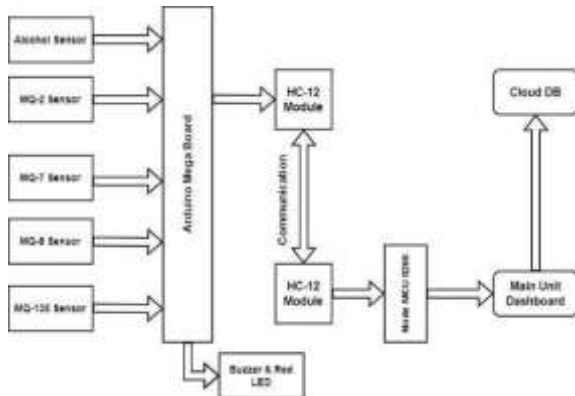

Fig. 4. Identification of ambient air quality and identification alcohol of mining worker

The main toxins explored inside the mine are carbon monoxide (CO), carbon dioxide (CO₂); The combustible gases are methane (CH₄), CO and hydrogen (H₂); The suffocating gases are CO₂, nitrogen (N₂O) and CH₄; And toxic gases are CO, nitrogen oxides (NO_x) and hydrogen sulfide (H₂S).

These gases are formed due to various chemical changes. The sensors used for this helmet are MQ-7 = carbon monoxide, MQ-135 = carbon dioxide, MQ-2 = LPG and methane, and MQ-8 detects hydrogen. All of these sensors detect a toxic gas and the red LED bulb and buzzer alert the miner about the harmful gases. For example, when the MQ-135 sensor detects an adverse level of carbon dioxide, the above-mentioned operating machinery activates and notifies the miner.

Alcohol sensor is used to detect alcohol level. For example, if a miner has used alcohol, the alcohol sensor detects it and notifies the main control center.

D. To explore, automate, predict and report miner's health status

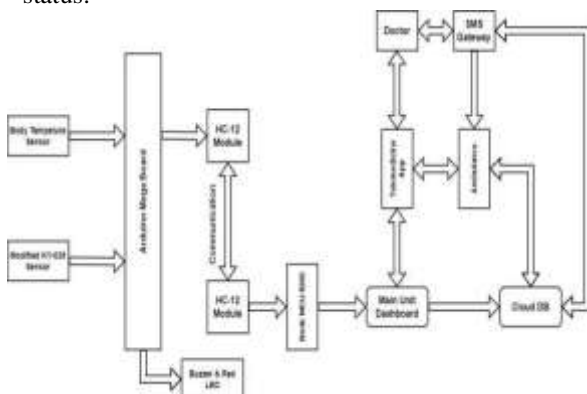

Fig. 5. Predict and report miner's health status

In this case, it uses a pulse sensor, a human body temperature sensor, and a blood oxygen sensor. It can detect heart rate, body temperature and humidity as well as oxygen levels in the body (blood). This component retrieves data about the body of the miner and does not detect the temperature around the workplace.

If the pulse speed of the above sensor is high and the oxygen level in the body is low, it will also notify the miners and the instrument panel. The miner and instrument panel are notified using a red LED bulb and buzzer. Pink LEDs are used for oxygen and the instrument panel is illuminated in the same color. Because it is the world's recommended color to detect low oxygen levels. Also, by using a temperature sensor to detect body temperature, the humidity test is a reminder to drink a little water every 30 meters, depending on the temperature.

Added the telemedicine concept to this system, which is specially proven for miner safety.

The main reason for using this concept is to check the health status and inform the miners about it and the dashboard may not be good. This is because in case of ill health, the miner can rest on notice. Then using this concept, the Chief Control Unit can obtain medical recommendations from the doctor within a short period of time. This new telemedicine concept, which had not been used before, was used for that process.

It works by using a web application. If the health status data of the data obtained mainly from the dashboard is bad, that data is sent to the doctor through the web app and after receiving the details of the patient, it is informed to the doctor's app. Then the doctor can find out about it and look at the patient's details like heart rate, temperature and blood oxygen level. Then the doctor can prescribe the medicine according to the health status data and it is legal.

After checking the health status data and the doctor, the prescription can be sent through the web application. It can then be added to the main control unit and given to the drug miner. This web application will be used by the mining company's chief control unit, medical and emergency vehicle drivers. Then the driver of the vehicle also has an urgent need so be prepared for it. If users (doctor, emergency driver, master control unit) are not online, notification will also be given via SMS. Then they can check the web application.

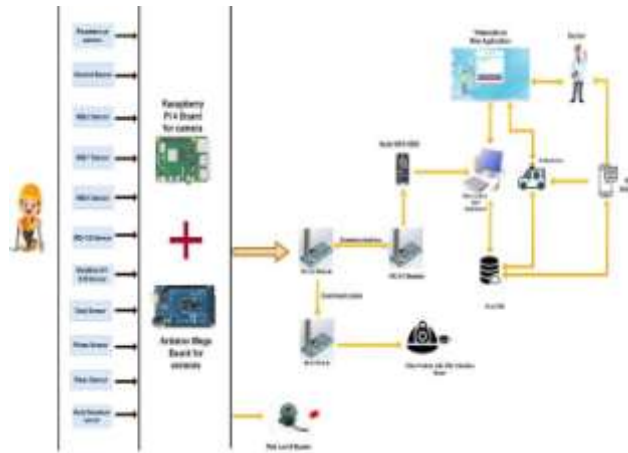

Fig. 6. System diagram

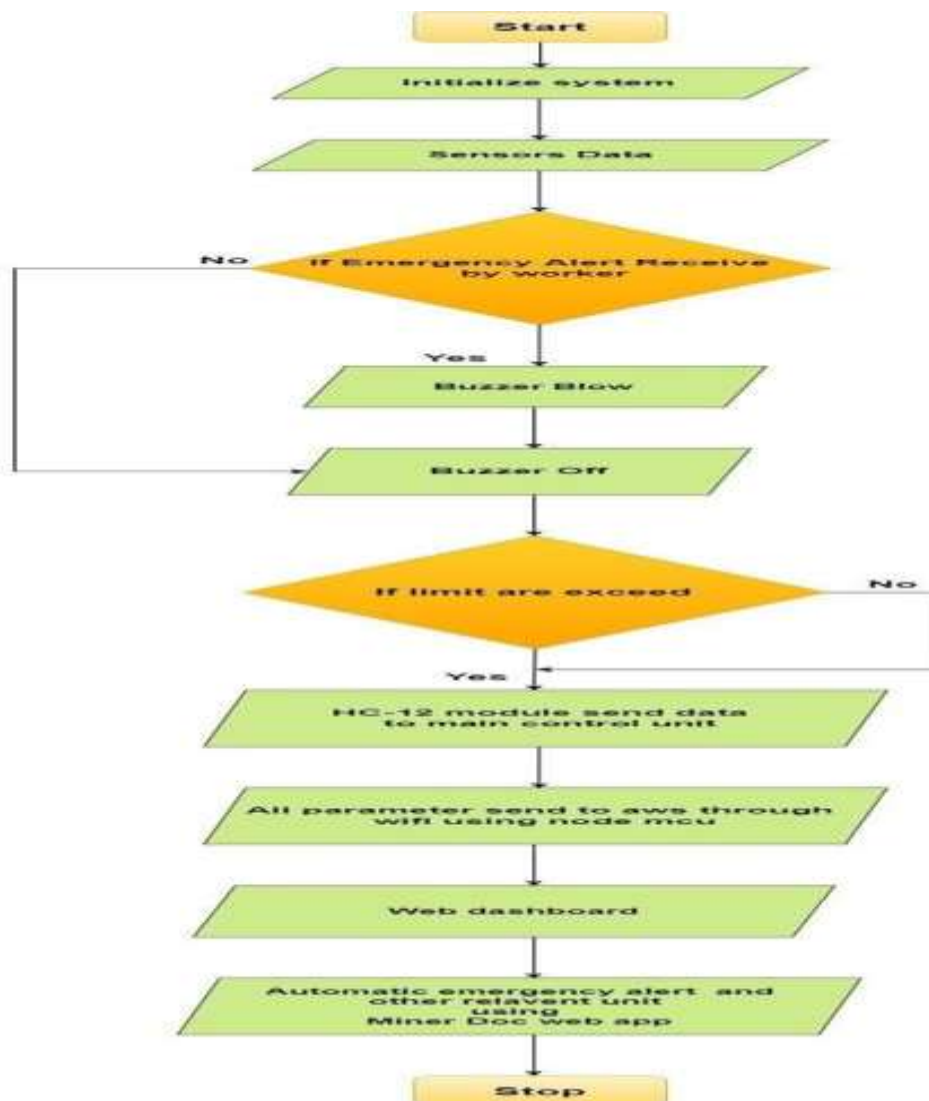

Fig. 7. I-Helmet functions flow

III. RESULTS AND DISCUSSIONS

This research aims to create a software and hardware solution that can better manage the aspects of mining industry. Although many such systems have been built, we wanted to focus on some key areas that needed more attention, we have taken them as separate components and have built solutions that address the specific issues and provide a better, simplistic solution. So far, the system works as intended with minimal errors. An all-purpose software solution for mining site, we hope that this system can alleviate the most problematic issues faced by miners in mining site.

In this system can calculate the amount of dust and identify the amount of fire. Also using image processing can detect human body parts in some accident like mine collapses and can explore and identify physical structure of mining site. Also, can explore about damage areas, wet- areas, striped grounds and cracked walls. Furthermore, using this camera module can detect objects in mining industry.



Fig. 8. Arduino serial monitor

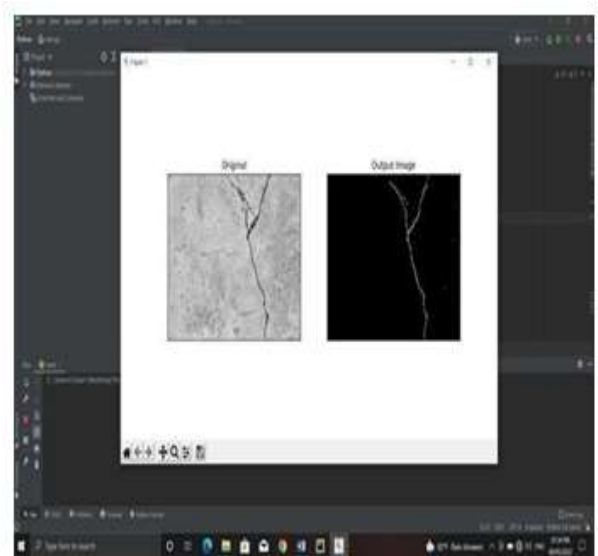

Fig. 9. Cracks wall

Also, in this system can detect human body oxygen level, Pulse rate and temperature. After detecting that data, it will send to the main control unit dashboard and after that health condition data will send to the doctors through telemedicine app. Using this app doctors can send the medical prescription to the main control unit.

To detect human blood oxygen level used KY-039 sensor and modified it using RED LED. To measure oxygen saturation, we first need to learn how a heartbeat sensor work. I've got a heartbeat sensor named KY-039 which is made with an infrared led and a photodiode. The photodiode must be able to receive 940nm infrared light. Since we also need (in next steps) to receive the red light (if you're building the sensor from scratch) you will need a photodiode with a wide spectral range to receive light new 600nm (red) and near 940nm (infrared).

In addition, we proposed telemedicine application with other requirements.



Fig. 10. I-Helmet dashboard

IV. CONCLUSION

The camera currently on the i-helmet can also monitor the mine environment and accidents in the mine. The I-Helmet can detect harmful gases inside the mine. The I-Helmet can also be used to identify a miner's health and alcohol levels. The other helmet vibrates so that if something falls on the head, other workers can know it. The I-Helmet also detects fire and dust. Because RF technology was used to send data to the main control center, that task could be done very quickly. Future researchers could improve this i-helmet. Although this helmet is currently being used in mining, future researchers can use this i-helmet in a variety of fields. That is, it can be used for industry. Then you can also communicate with the main control center via Wi-Fi. Voice recognition devices can also be connected to the main control center so that the miner can speak.

V. ACKNOWLEDGMENT

Appreciation and gratitude to everyone who encouraged us and pushed us to reach our goals in a variety of ways, including through words. Special thanks to our parents and colleagues for supporting us along the way.

VI. REFERENCES

[1] Baru.V.B and Borkar.S.P . (2018). IoT Based Smart Helmet for Underground Mines, (Pg52-56).
 [2] Jagadeesh.R and Nagaraja.R.(2017). IoT based Smart Helmet for unsafe event detection for mining industry, (Pg1487-1492).
 [3] AlAdilee.M.K.A, Abdulla.R, Nataraj.C and Eldemer dash.T. (2020) . Iot Based Helmet for Mining Industry, <https://www.researchgate.net/publication/340261013>, (pp. 373 – 387).
 [4] Govind.A, Varshney.A, Jaiswal.N, Kumar.S,

Sirohi.S, Kumar.A and Kumar Singh.R.(2017). Smart Helmet, <http://doi.org/10.22214/ijraset.2017.4185>.
 [5] Choi.Y and Kim.Y.(2021). Applications of Smart Helmet in Applied Sciences: A Systematic Review. <https://doi.org/10.3390/app11115039>.
 [6] Nandhini.M, Padma Priya G.V, Nandhini. S and Dinesh.K.(2018). IoT based Smart Helmet for Ensuring Safety in Industries, (Pg1-4).
 [7] Gupta.N , Kaur.R, Gupta.R, Lakshmi.S.S and Dagar.A.(2021). A Technical Review on IoT Based Mining Tracking and Safety Helmet, <https://doi.org/10.21276/ijrcst.2021.9.4.11>.
 [8] Chandran.S, Chandrasekar.S and Elizabeth.E.(2017).An Internet of Things (IoT) based Smart Helmet for Accident Detection and Notification, DOI: 10.1109/INDICON.2016.7839052.
 [9] LAVANYA.S, REDDY.A.K.(2017). Hazards Detection Using Smart Helmet Sensing Technology In The Mining Industry, (Pg1120-1124).
 [10] Behr.C. J, Kumar.A and Hancke.G.P.(2016). A Smart Helmet for Air Quality and Hazardous Event Detection for the Mining Industry, DOI: 10.1109/ICIT.2016.7475079.
 [11] Balaji.N and Chandrakala.B.(2017).An Intelligent Device for Hazardous Event Detection for Mining Industry - Smart Helmet, <https://dx.doi.org/10.22161/ijaers/nctet.2017.ece.14>.
 [12] Sangeetha.M and Gangopadhyay.A .(2018).Air Quality and Hazardous Event Detection with a Smart Helmet for the Mining Industry, (Pg1-6).
 [13] Panchbuddhe.P.G and Pathan.T.(2018). A Microcontroller Based smart helmet for coal miners for air quality and hazardous event detection, (Pg594-603).
 [14] Paulchamy.B, Natarajan.C, Wahith.A.A, Sharan.P.V.M and Vignesh.R.H.(2018). Agile Methodologies for SoftwareDevelopment, <https://www.kpipartners.com/blog/traditional-vs-agile-software-development-methodologies>.
 [15] Seelan.S, Krittika.J, Getsiah.C and Arunachalam.B.(2021). IOT BASED INTELLIGENT HELMET FOR MINERS, DOI: 10.34218/IJEET.12.3.2021.018, (pp. 123-128).
 [16] Borkar.S.P and Baru.V.B.(2018). A Smart Helmet for Mining Industry,(Pg547-550).
 [17] Pawar.V.R and Shejule.R.A.(2020).IOT BASED SMART HELMET FOR UNSAFE EVENT DETECTION FOR MINING INDUSTRY, <https://doi.org/10.37896/aj9.9/054>.
 [18] Yesukumara.R.K and Gowda.S.K.(2017). MINE SAFETY SYSTEM USING HELMET AND INTERNET OF THINGS, (Pg147-149).

IJEAST

INTERNATIONAL JOURNAL
OF ENGINEERING APPLIED SCIENCE
AND TECHNOLOGY

ABOUT IJEAST

International Journal of Engineering Applied Science and Technology (IJEAST) is a peer-reviewed, open access journal that publishes high-quality research papers in the field of Engineering, Applied Science and Technology.

IJEAST aims to provide a platform for researchers, academicians, and professionals to share their innovative ideas, research findings, and practical experiences with the global scientific community.

FOCUS AREAS

- Engineering
- Applied Science
- Technology
- Innovation & Development
- Interdisciplinary Studies



PEER REVIEWED

All submissions are rigorously peer reviewed to ensure quality.



OPEN ACCESS

Free and unrestricted access to research for all.



GLOBAL REACH

Connecting researchers and professionals worldwide.



TIMELY PUBLICATION

We ensure a swift and efficient publication process.



For more information, visit our website

www.ijeast.com



INTERNATIONAL JOURNAL
OF ENGINEERING APPLIED SCIENCE
AND TECHNOLOGY

✉ editor@ijeast.com

🌐 www.ijeast.com

📍 India



2455-2143