



IJEAST

INTERNATIONAL JOURNAL
OF ENGINEERING APPLIED SCIENCE
AND TECHNOLOGY



VOLUME : 2 ISSUE : 4 Print / Issue Publication Date: 31-Mar-2017



ISSN : 2455-2143



Indexed In



WWW.IJEAST.COM

editor@ijeast.com



AN OVERVIEW OF DIFFERENT TYPES OF WIND GENERATOR SYSTEMS

Shilpi
Department of EE
HCE, Sonapat, Haryana, India

Dr. Rajveer Mittal
Department of EEE
MAIT, Rohini, Delhi, India

Abstract— Today the major energy requirements have fulfilling by conventional sources out of which coal based thermal power generation is having major contribution. But such facts like the rate at which conventional sources are being utilized and their influence on natural world, it is essential to adopt alternate energy technologies which are more consistent. The world is now moving forward with an initiative to fasten the growth of renewable sources of energy . Wind energy is one of the most cost effective energy source which is used to give electricity among different renewable resources and have the potential to fulfill our energy needs. Considering the challenges to be faced with interconnection of large wind farms using different types of generators like as Induction and Synchronous generators, it become necessary to study the various types of wind generator systems and their differences.

Keywords— Alternating Current (AC); Direct Current(DC); Doubly Fed Induction Generator (DFIG); Permanent Magnet Synchronous Generator (PMSG); Squirrel Cage Induction Generator (SCIG); Wound Rotor Induction Generator (WRIG).

I. INTRODUCTION

The fastest growing energy technology in the World is generation of electricity from wind. The wind speed is extremely important for the amount of energy. Winds are essentially caused by solar heating of the atmosphere; they carry huge quantity of energy. This wind energy is used to drive a wind turbine, which is coupled with an electrical generator[11]. The kinetic energy of the moving air (wind) is required to rotate the blades of the wind machine. The blades play important role in conversion of wind energy into mechanical energy, and generator is used to convert this energy into electrical energy. For a fixed speed wind turbine there is direct connection between generator and electrical grid[1] When fixed-speed wind turbine with induction generator is directly connected to grid, there are drawbacks i.e., reactive power so the level of grid voltage cannot be controlled. These drawbacks are avoided by using variable-speed wind turbines [6]. These turbines improve the dynamic behaviour of the turbine and reduce the noise at low wind speeds. Power electronic equipment is used to control generator in case of variable speed wind turbine[3]. Variable

speed wind turbine has possibilities to overcome stresses of the mechanical structure, acoustic noise reduction and control active and reactive power[1] Doubly fed induction generator is more preferable because of its several advantages. The DFIG technology is used to obtain paramount energy from the wind for low wind speeds by improving the turbine speed, while reducing mechanical stresses on the turbine during blow of wind [1][2]

II. TYPES OF WIND ENERGY SYSTEMS

A. Fixed-Speed Wind Energy Systems

These turbines are furnished with an induction generator that is directly connected to the grid, along a soft-starter and a capacitor bank for decreasing reactive power compensation. They are constructed to obtain paramount efficiency at particular wind speed. Some fixed-speed wind turbines has two winding sets for increment in power generation.[1]

• Squirrel Cage Induction Generator:

In these types of generators, the rotor winding has un-insulated conductors; in the form of copper and aluminum bars inserted in the semi closed slots.[5] The solid bars are short circuited at both terminals by end a ring of which is made up of same material. With the absence of rotor core, the rotor bars and end rings look like the cage of a squirrel. The rotor bars construct a evenly distributed winding in the rotor slots. As illustrated in Figure the SCIG is directly grid connected. Only a few percent change occurs in SCIG speed because of the generator slip induced by changes in wind speed. So, this generator is used for fixed-speed wind turbines. The main problem is magnetizing current due to which the full load power factor is almost low. If power factor is very low then it is compensated by connecting capacitors in parallel to the generator. SCIG is furnished with a soft-starter mechanism and capacitor bank is used for reactive power compensation. Fluctuations in wind power are tranfering directly to the grid and it must be observed for weak grids.

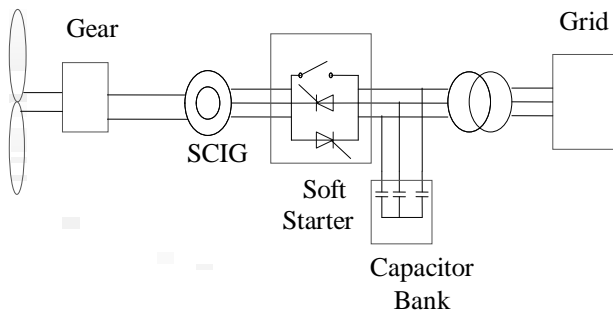

Fig. 1. Squirrel Cage Induction Generator

In the condition of fault, SCIGs without any reactive power compensation system can occur voltage transients on the grid. The wind turbine rotor may speed up, for instance, when a fault exists, due to the inequality between the electrical and mechanical torque.[41][42]

B. Variable-Speed Wind Energy Systems:

These turbines are constructed to obtain paramount aerodynamic efficiency over a vast limit of wind speeds. The electrical system of variable wind speed turbine is more difficult than that of a fixed-speed wind turbine. It is furnished with an induction or synchronous generator and power converter is used to connect with grid. This power converter controls the speed of generator. [39][41][42]

C. Asynchronous or Induction Generator:

These types of generator use magnetic induction principle to transposition the electrical energy from stator to rotor, without any wire contact. External source is used to give power to stator causing the rotor to turn. The rotating magnetic flux in the stator is greater than the rotating speed of rotor. These types of generator are also known as asynchronous machine.[32] When the rotor speed go beyond rotating magnetic field in the stator, direction of rotor is steady with rotating magnetic field, the rotor will move to pick the stator field faster. Due to this , a reverse torque in the rotating direction induced , thus induction generator is operate as a generator at the frequency and voltage of the initial power supply to the stator. . The definition of rotating difference ratio for an induction generator is as

$$s=(N_{syn}-N_m/N_{syn})*100 \quad (1)$$

Where,

Nsyn=synchronous speed of magnetic field (rpm)

Nm= rotating speed of rotor (rpm)

- **Limited Variable Speed Induction Generator:-**

These types of induction generator have a variable slip and to select the maximum slip, resulting in smaller variations in torque and power output. To achieve load Reductions variable slip is required which is very simple, predictable and cost-effective. WRIG has a variable external rotor resistance which is used to control the slip. The converter is optimally controlled, i.e, no slip rings are required. The stator of the generator is directly coupled to the grid .[39][41][42]

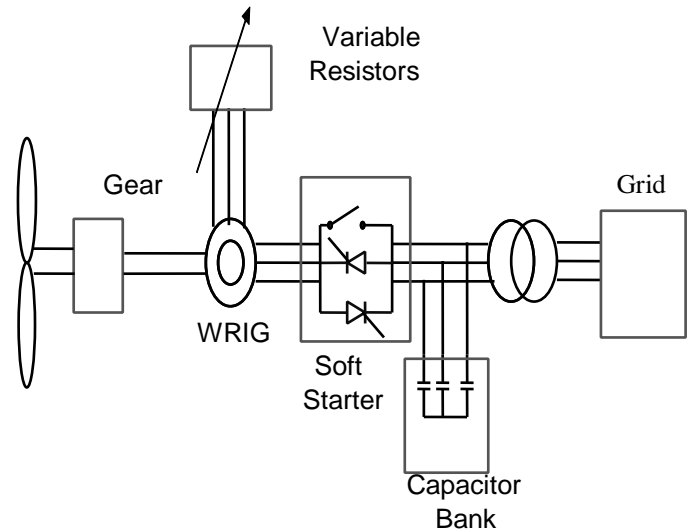

Fig. 2. Wound Rotor Induction Generators

The advantages are having a simple circuit topology, no need for slip rings and operating speed range is better than the SCIG. However, it still requires a reactive power compensation system. The disadvantages are speed range is typically limited to 0–10 %, low control of active and reactive power is obtained and the slip power is consumed in the inconstant resistance as losses.[39]

Doubly fed induction generator:

In DFIG the voltage on the stator is applied from the grid side and the voltage on the rotor is induced by the power converter. [11]This system permits a variable-speed operation over a wide, but controlled range. The difference between the mechanical and electrical frequency is compensating by converter by providing a rotor current with a variable frequency.[29] During both the conditions whether normal operation or faults the behavior of the generator is governed by the power converter and its controllers.[24][25]

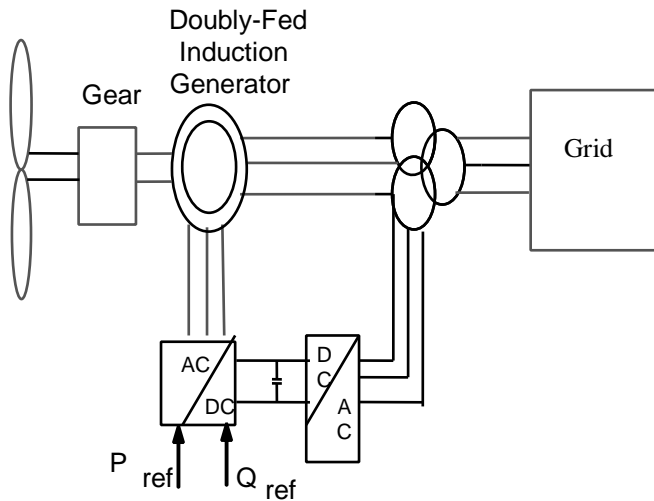

Fig. 3. Doubly Fed Induction Generator

The power converter has two converters, the rotor-side converter and grid-side converter, which are controlled separately of each other. The rotor-side converter controls the both powers active and reactive by regulating the rotor current components, Although the line-side converter controls the DC-link voltage and provide a converter operation at unity power factor. The DFIG has several advantages, i.e, not naturally magnetized from the power grid; magnetized from the rotor circuit, . It is capable of generating reactive power that can be supplied to the stator by the help of grid-side converter. In the case of a weak grid, means voltage may fluctuate, the DFIG may be used to yield or consume an amount of reactive power to or from the grid, for voltage control needs direct current to be supplied to the rotor winding via slipping to produce the rotor's magnetic flux. The converter used in DFIG is back to back converter.[24][25][33]

D. Synchronous generator:

A synchronous generator is a type of generator which operates in synchronism with rotating speed of an AC system to which it is connected. Wind turbines having synchronous generators normally use electromagnets in the rotor which are fed by direct current from the electrical grid. Since the grid provides alternating current, they first have to convert alternating current to direct current before sending it into the coil windings around the electromagnets in the rotor[31][42].

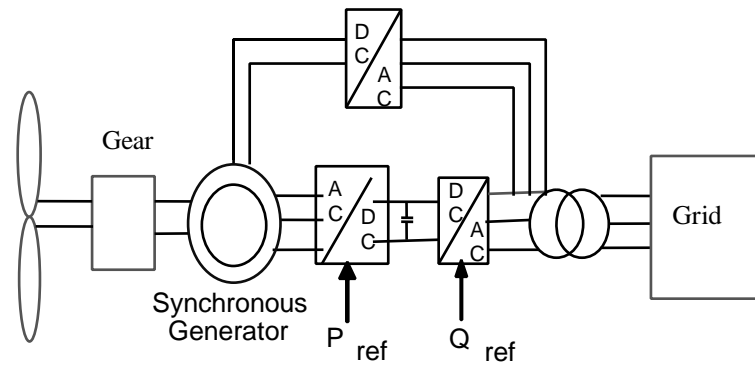

Fig. 4. Synchronous Generator

The prime mover drives the generator rotor creating a rotating magnetic field that produces a voltage in the stator windings. The windings of the stator are formed in such a way so that a three-phase voltage is produced. The induction voltage of alternating current is given by the following equation-

$$E = K\phi\omega_{syn} \tag{2}$$

Where,

K-electrical coefficient of generator

ϕ - rotor magnetic flux (Wb)

ω_{syn} : Angular velocity of rotor rotating at synchronous speed.

• **Permanent Magnet Synchronous Generator (PMSG):**

In Permanent magnet machine the efficiency is higher than that of induction machine, be the excitation is provided without any energy supply[7]. Though, the materials used for providing permanent magnets are costly, and challenging to work during accomplishment. Additionally, the use of PM excitation requires full scale power converter to regulate the voltage and frequency of generation to the voltage and the frequency of transmission, respectively.[13][38]

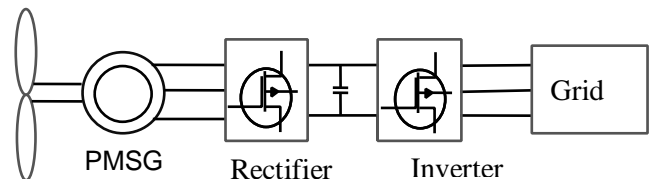

Fig. 5. Permanent Magnet Synchronous Generator

The contemporary feature of the PMSG may occur problems during start-up, synchronization and voltage regulation.



Constant voltage does not provided by it. Magnetic materials are sensitive to temperature. So, temperature of rotor of a PMSG must be managed and a cooling system is required. As the rotating magnetic field is stable and the rotor rotating speed changes with wind velocity, the output voltage and frequency are volatile and can't serve a fixed power supply. PMSG are not suitable for commercial applications because of their small extent and higher cost per kilowatt of output. It is only suitable for remote areas without a grid power [38]

E. Self-Excited Induction Generator (SEIG):

A capacitor bank is used for the excitation of SEIG. Capacitor Bank is connected across stator terminals of Induction Generator. Capacitor bank gives the reactive power to the load. The excitation capacitance gives a dual purpose for standalone induction generator: first vibrating with the help of machine inductance in a negatively damped, resonant circuit to build up the terminal voltage from the value of zero with the help of permanent magnetism of the machine, and then by giving reactive power improving the power factor of the machine.[41][42]

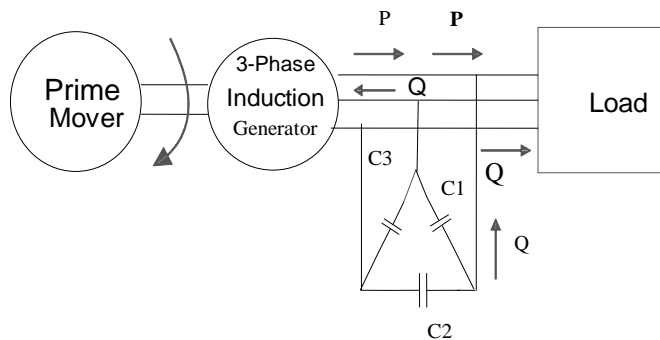

Fig.6. Self Excited Induction Generator

The parameters of the induction machine, the self-excitation process, the load parameters and type of primary mover are the main factors affecting the behaviour of the SEIG system.

The induction generator's ability to generate power at varying speed facilitates its application in various modes such as self-excited stand-alone (isolated) mode; in parallel with synchronous generator to supplement the local load, and in grid-connected mode[34][35]

III. GENERATORS USED BY MANUFACTURERS COMPANIES:

Manufacturer	Concept
Vestas (Denmark)	Doubly -Fed Induction Generator (DFIG) PMSG, multiple gearbox with full converter
General Electric (US)	Doubly -Fed Induction Generator (DFIG) PMSG, multiple gearbox with full converter PMSG Direct Drive with

	Full Converter
Sinovel (China)	Doubly -Fed Induction Generator (DFIG) PMSG, multiple gearbox with full converter PMSG Direct Drive with Full Converter
Enercon (Germany)	EESG Direct Drive with Full Converter
Goldwind (China)	PMSG Direct Drive with Full Converter Doubly Fed Induction Generator
Gamesa (Spain)	Doubly Fed Induction Generator (DFIG)PMSG multiple gearbox with full Converter
Dongfang (China)	Doubly -Fed Induction Generator (DFIG)
Suzlon (India)	IG; Fixed or Limited variable speed
Siemens (Germany)	IG; Multiple gear box with Full Converter Direct Drive
Repower (Germany)	Doubly Fed Induction Generator (DFIG)

Table.1. Top 10 Globally Wind Turbine Manufactures, Used Generator Concepts [3][42]

IV. COMPARISION BETWEEN WIND ENERGY SYSTEMS

The fixed-speed wind turbine has the advantage, i. e, simple, rugged, steady, and well-proven and price is not so much high of its electrical parts[15] Its disadvantages are an uncontrollable reactive power consumption, mechanical force and control of power quality is limited. Because of constant speed operation, all variations in the wind speed are further transferred as change in mechanical torque and also in the electrical power on the grid. Most of the drawbacks of fixed wind energy systems are desisted by use of variable wind energy systems. In variable speed wind energy systems power electronics converter is required. Basically, a wind energy system can be equipped with any type of three-phase generator, such as synchronous generator and asynchronous generator. Out of these, DFIG (Asynchronous Generator) is more preferable because of its several advantages. The DFIG technology is used to obtain maximum energy from the wind for low wind speeds by optimizing the turbine speed, while minimizing mechanical stresses on the turbine during explosion of wind. [27] In DFIG Technology, Power electronic converters are used to generate or absorb reactive power, thus discarding the need for installing capacitor banks as in the case of SCIG.[10] The drawbacks of SCIG are that the generator iron core must be saturated to stabilize the voltage, which leads to a poor efficiency, and the capacitance value must be changed with the generator speed. The



advantages of PMSG are that light weight, small size, Low losses and high efficiency, No requirement of external excitation current and gearbox.[14][25] And disadvantages are that it is useful for small wind that has to be increased, Demagnetization of permanent magnet due to atmospheric conditions is a big problem.

V. CONCLUSION

This paper presented a brief and comprehensive survey of the different types of generator and power electronic approaches used by the modern wind turbine industry. wind turbine technologies and control design, was followed by the state of the art of wind turbines, from an electrical aspect. It is obvious that the introduction of variable-speed options in wind turbines improves the quantity of suitable generator types and further gives different combination of generator type and power electronic converter. Power electronic devices are rising scientific solutions to contribute wind power positions with power system regulate capacities and to improve their effect on power system stability.

VI. REFERENCE

- [1]. A. Grauers et al., "Efficiency of three wind energy generator systems," IEEE Trans. Energy Conversion, vol. 11, pp. 650-657, September 1996.
- [2]. Abou-Zaid, M., El-Attar, M., & Moussa, M. (1999). "Analysis and Performance of axial field switched reluctance generator". In International Conference on Electric Machines and Drives. 141-143
- [3] L.H. Hansen et al., "Generators and power electronics technology for wind turbines," in Proceedings of IEEE IECON'01, vol. 3, pp. 2000-2005, Denver (USA), November-December 2001.
- [4] D.A. Torrey, Switched reluctance generators and their control, IEEE Transactions on Industrial Electronics, 49(1), 00 3-014, 2002
- [5] C. Nicolae et al., "Guidelines for the design and control of electrical generator systems for new grid connected wind turbine generators," in Proceedings of IEEE IECON'02, vol. 4, pp. 3317- 3325, Seville (Spain), November 2002.
- [6] I. Boldea, "Control of electric generators," in Proceedings of IEEE IECON'03, vol. 1, pp. 972- 980, Roanoke (USA), November 2003.
- [7]. Tan, K.; and Islam, S. (2004). Optimum control strategies in energy conversion of PMSG wind turbine system without mechanical sensors. IEEE Transactions on Energy Conversion, 19(2), 392-399.
- [8] P. Thøgersen et al., "Adjustable speed drives in the next decade. Future steps in industry and academia," Electric Power Components & Systems, vol. 32, n°1, pp. 13-31, January 2004.
- [9] H. Polinder et al., "Basic operation principles and electrical conversion systems of wind turbines s," In Proceedings of NORPIE'04, Paper #069, Trondheim (Norway), June 2004.
- [10] B. Blaabjerg et al., "Power electronics as efficient interface in dispersed power generation systems," IEEE Trans. Power Electronics, vol. 19, n°5, pp. 1184-1194, September 2004
- [11] J. A. Baroudi et al., "A review of power converter topologies for wind generators," in Proceedings of IEEE IEMDC'05, pp. 458-465, San Antonio (USA), May 2005.
- [12] Johan Morren, student IEEE and Sjoerd W.H. de Hann, member IEEE, Ride through of wind turbines with doubly fed induction generator during a voltage dip, IEEE transaction on energy conversion, vol. 20 No. 2 June 2005
- [13] M. A. Khan et al., "On adapting a small pm wind generator for a multiblade, high solidity wind turbine," IEEE Trans. EnergyConversions, vol. 20, n°3, pp. 685-692, September 2005.
- [14] J. R. Bumby et al., "Axial-flux permanent-magnet air-cored generator for small-scale wind turbines," IEE Proc. Electric Power Applications, vol. 152, n°5, pp. 1065-1075, September 2005.
- [15] H. Polinder, F. F. A. van der Pijl, G. J. d. Vilder & P. J. Tavner, Comparison of direct-drive and geared generator concepts for wind turbines, IEEE Transactions on Energy Conversion, 21(3), 725-733, 2006
- [16] E. Koutroulis et al., "Design of a maximum power tracking system for wind-energy-conversion applications," IEEE Trans. industrial Electronics, vol.53, n°2, pp. 486-494, April 2006.
- [17]. Iov, F.; Teodorescu, R.; Blaabjerg, F.; Andersen, B.; Birk, J.; and Miranda, J. (2006). Grid code compliance of grid-side converter in wind turbine systems. Proceedings of 37th IEEE Power Electronics Specialists Conference, 1-7.
- [18]. Chinchilla, M.; Arnaltes, S.; and Burgos, J.C. (2006). Control of permanent magnet generators applied to variable-speed wind-energy systems connected to the grid. IEEE Transactions on Energy Conversion, 21(1), 130-135.
- [19]. Blaabjerg, F.; Teodorescu, R.; Liserre, M.; and Timbus, A.V. (2006). Overview of control and grid synchronization for distributed power generation systems. IEEE Transactions on Industrial Electronics, 53(5), 1398-1409
- [20]. Kowalski, C.; Lis, J.; and Kowalska, O.T. (2007). FPGA implementation of DTC control method for induction motor drive. Proceedings of The International Conference on Computer as a Tool, EUROCON, Warsaw, 1916-1921
- [21]. Munteanu, I.; Bacha, S.; Bratcu, A.I.; Guiraud, J.; and Roye, D. (2008). Energy-reliability optimization of wind energy system by sliding mode control. IEEE Transactions on Energy Conversion, 23(3), 975-985.
- [22]. Wei, Q.; Wei, Z.; Aller, J.M.; and Harley, R.J. (2008). Wind speed estimation based sensorless output maximization control for a wind turbine driving a DFIG. IEEE Transactions on Power Electronics, 23(3), 1156-1169.
- [23] Y. Duan, R. G. Harley & T. G. Habetler, Multi-objective design optimization of surface mount permanent magnet machine with particle swarm intelligence, IEEE SIS, 001-005, 2008.



[24]. Cardenas, R.; Pena, R.; Clare, J.; Asher, G.; and Proboste, J. (2008). MRAS observers for sensorless control of doubly-fed induction generators. *IEEE Transactions on Power Electronics*, 23(3), 1075-1084.

[25]. Peña, R.; Cardenas, R.; Proboste, J.; Asher, G.; and Clare, J. (2008). Sensorless control of doubly-fed induction generators using a rotor current based MRAS observer. *IEEE Transactions on Industrial Electronics*, 55(1), 330–339.

[26]. Muhando, B.; Senjyu, T.; Kinjo, H.; and Funabashi, T. (2009). Extending the modeling framework for wind generation systems: RLS-based paradigm for performance under high turbulence inflow. *IEEE Transactions on Energy Conversion*, 24(1), 211-221.

[27]. Mishra, S.; Mishra, Y.; Li, F.; and Dong, Z.Y. (2009). TS-fuzzy controlled DFIG based wind energy conversion system. *Proceedings of IEEE Power and Energy Society General Meeting, Canada*, 1-7.

[28]. Li, H.; Chen, Z.; and Polinder, H. (2009). Optimization of multibrid permanent magnet wind generation systems. *IEEE Transactions on Energy Conversion*, 24(1), 82-92.

[29]. Abad, G.; Rodriguez, M.A.; Iwanski, G.; and Poza, J. (2010). Direct power control of doubly-fed-induction-generator-based wind turbines under unbalanced grid voltage. *IEEE Transactions on Power Electronics*, 25(2), 442-452.

[30]. Kairous, D.; Wamkeue, R.; and Belmadani, B. (2010). Sliding mode control of DFIG based variable speed WECS with flywheel energy storage. *Proceedings of XIX International Conference on Electrical Machines, ICEM (IEEE)*, 1-6.

[31]. Liserre, M.; Sauter, T.; and Hung, J.Y. (2010). Future Energy Systems: Integrating Renewable Energy Sources into the Smart Power Grid through Industrial Electronics. *IEEE Industrial Electronics Magazine*, 4(1), 18-37.

[32]. Cirrincione, M.; Pucci, M.; Cirrincione, G.; and Capolino, G.-A. (2011). Sensorless control of induction motor by a new neural algorithm: The TLS EXIN neuron. *IEEE Transactions on Industrial Electronics*, 54(1), 127-149

[33]. Liu, C.H.; and Hsu, Y. (2011). Effect of rotor excitation voltage on steady state stability and maximum output power of a doubly fed induction generator. *IEEE Transactions on Industrial Electronics*, 58(4), 1096-1109.

[34]. Mansour, M.; Mansouri, M.N.; and Mmimouni, M.F. (2011). Study and control of a variable-speed wind-energy system connected to the grid. *International Journal of Renewable Energy Research*, 1(2), 96-104.

[35]. Cirrincione, M. Pucci, M.; and Vitale, G. (2011). Neural MPPT of variable speed wind generators with induction machines in a wide speed range. *Proceedings in IEEE Conference on Energy Conversion Congress and Exposition*, 857-864

[36]. Liserre, M.; Cardenas, R.; Molinas, M.; and Rodriguez, J. (2011). Overview of multi-MW wind turbines and wind parks. *IEEE Transactions on Industrial Electronics*, 58(4), 1081-1095.

[37] Z. Zhang, A. Matveev, S. Øvrebø, R. Nilssen & A. Nysveen, Review of modeling methods in electromagnetic and thermal design of permanent magnet generators for wind turbines, *IEEE ICCEP*, 377- 382, 2011

[38] X. Yang, D. Patterson & J. Hudgins, Permanent magnet generator design and control for large wind turbines, *IEEE PEMWA*, 001-005, 2012

[39] J.A. Baroudi, V. Dinavahi, & A. M. Knight, A review of power converter topologies for wind generators, *IEEE IEMDC*, 458-465, 2005.

[40] J. Bhukya, Modeling and analysis of double fed induction generator for Variable Speed Wind Turbine, *IEEE ICEETS*, 1324-1329, 2013.

[41] H. Polinder, J. A. Ferreira, B. B. Jensen, A. B. Abrahamsen, K. Atallah & R. A. McMahon, Trends in wind turbine generator systems, *IEEE Journal of Emerging and Selected Topics in Power Electronics*, 1(3), 174- 185, 2013.

[42] Neha Verma, Arun Pachori, "Theoretical Approach for Comparison of Various Types of Wind Generator Systems" *International Journal of Recent Research in Electrical and Electronics Engineering (IJRREEE)* Vol. 2, Issue 2, pp: (29-35), Month: April 2015 - June 2015

IJEAST

INTERNATIONAL JOURNAL
OF ENGINEERING APPLIED SCIENCE
AND TECHNOLOGY

ABOUT IJEAST

International Journal of Engineering Applied Science and Technology (IJEAST) is a peer-reviewed, open access journal that publishes high-quality research papers in the field of Engineering, Applied Science and Technology.

IJEAST aims to provide a platform for researchers, academicians, and professionals to share their innovative ideas, research findings, and practical experiences with the global scientific community.

FOCUS AREAS

- Engineering
- Applied Science
- Technology
- Innovation & Development
- Interdisciplinary Studies



PEER REVIEWED

All submissions are rigorously peer reviewed to ensure quality.



OPEN ACCESS

Free and unrestricted access to research for all.



GLOBAL REACH

Connecting researchers and professionals worldwide.



TIMELY PUBLICATION

We ensure a swift and efficient publication process.



For more information, visit our website
www.ijeast.com



INTERNATIONAL JOURNAL
OF ENGINEERING APPLIED SCIENCE
AND TECHNOLOGY

✉ editor@ijeast.com

🌐 www.ijeast.com

📍 India



2455-2143