



IJEAST

INTERNATIONAL JOURNAL
OF ENGINEERING APPLIED SCIENCE
AND TECHNOLOGY



VOLUME : 7 ISSUE : 07 Print / Issue Publication Date: 10-Feb-2023



ISSN : 2455-2143



DOI : 10.33564/IJEAST.2022.v07i07.036

Indexed In



WWW.IJEAST.COM

editor@ijeast.com



ELECTRO-OCULOGRAPHY AS AN ALTERNATE COMMUNICATION IN THE FIELD OF HUMAN INTERFACING SYSTEM

Nupur Pranay Malwatkar
Department of Electronics Engineering
YCCE, Nagpur, Maharashtra India

Abstract—In recent years several researchers are practicing on human interfacing techniques. Many techniques were successfully implemented and launched as commercial products for medical, aeronautics and bioinformatics communications. Still concerning electro-oculography interfacing for Human Computer Interface (HCI) has wide scope of development and real life implementations. Like EEG, EMG and ECG, EOG doesn't provide important body parameters which could be used for disease diagnosis but it has very wide applications in human and machine interactions. EOG could be used by paralyzed stroke patients are unable to normally communicate with their environment. For these patients, the only part of their body that is under their control is eye moments. The system will detect the variations in electric signal strength through voltage level near the eye area and generates a signal in order to control interactive device. Additionally, they are particularly suitable in the case of people with severe motor disorder, for example people with other physical disorder. Developing solutions for them involves different ways of using sensors that decides the user's needs and limitations, which in turn converts the user's intentions into commands. This paper submits the use of EOG signals for the different application control in different fields in current situation

Keywords—Electro-oculography, Alternate Communication, Human Computer Interface (HCI)

I. INTRODUCTION

Communication with the outside world is important for any person with any physical disorders and paralysis patients with little motor capabilities. A possible solution for communication and control without speech and hand movement must be used for such abled people. The application of using Electrooculography signals to control the HCI systems is by the bio-electric potentials produced in the body. Control of objects through eyes gained the interest of researchers in recent years. These AT devices are operated by man-machine interface with sensors receiving information provided by the person with disabilities to pilot a graphical user interface [1]. There are three main types of bioelectrical

signals used for controlling the assistive device, namely the electro-myogram (EMG), the electro-oculogram (EOG), electrocardiography (ECG) and the electroencephalogram (EEG), out of which the EOG signal is not give any parameter information for any detection of diseases. The linear relationship between EOG and eye movement makes the waveform easier to analyze. The EOG technique has been used for many applications such as controlling a wheelchair [3], a keyboard [4] or a television [5]. This paper presents the analysis of the eye gestures using EOG technique for alternate communication in the field of Human Interfacing System with the help of wired electrodes and signal conditioning circuits.

II. EYE STRUCTURE AND MEASUREMENT

A. Scientific Principle –

In Attached to the globe of the eye, there are three antagonistic muscle pairs, which relax and contract in order to induce eye movement. These pairs of muscles are responsible for horizontal, vertical, clockwise and anti-clockwise movement of eye. The movement of each eyeball in its orbit is caused by the contractions of six voluntary muscles attached to the surface of the eyeball. Four of the six muscles run straight from origin termed as recti muscles and the remaining two muscles are attached to the eyeball surface. Contractions of the recti muscles are controlled by way of motor pathways in the brain and three pairs of cranial nerves. Voluntary eye movements are initiated and controlled in the motor cortex of the frontal lobes. Cortical activity associated with motor control of the extra ocular muscles can be detected and recorded using conventional electro-encephalographic techniques. Electrooculography (EOG) is the measurement and interpretation of electro-oculogram, which are the electroencephalographic tracings obtained while the person, without moving the head, moves their eyes from one point to another.

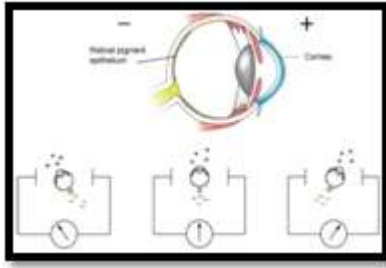
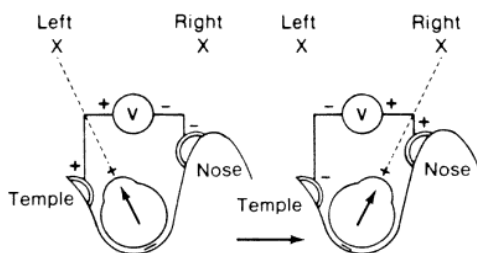

Fig. 1. Illustration of eye structure

Electro-oculography (EOG) is a technology of placing electrodes on person's forehead corner of the eyes to generate electrical pulse for each left and right, up and down movements. EOG is a very small electrical potential that can be detected using electrodes. The purpose is to sense the electro-oculography potential. EOG signals have an amplitude in the range of 10-100 μ V, the waveform can be observed on sound viewer. The electro-oculogram (EOG) is the electrical signal produced by the potential difference between the retina and the cornea of the eye. The EOG is measured in mVs in humans and is linearly proportional to eye displacement. The human eye is an electrical dual pole with a negative pole at the retina and a positive pole at the cornea

B. Signals Measurement –

This system may be used for increasing communication and/or control. The generated analog signals will be amplified using amplifier and then converted to digital signal and applied to microcontroller circuit and turned the devices on and off using relay switching circuit. The EOG is achieved placing two electrodes on the outer side corner of the eyes to detect horizontal movement and another pair above and below the eye to detect vertical movement. A reference electrode is placed between the two eyes. Eye movement will respectively generate voltage up to 15 μ V and 12 μ V.



III. AN ILLUSTRATION OF THE ELECTRO-OCULOGRAM (EOG).

The rotation of the eye to the right results in a difference of potential, with the electrode in the direction of movement (i.e., the right canthus) becoming positive relative to the second electrode. The opposite effect results from a rotation to the left, as illustrated. The calibration of the signal may be achieved by having the patient look consecutively at two different fixation points located a known angle apart and recording the

appropriate EOGs. Typical signal magnitudes range from 5-20 μ V/°. The signal generated by horizontal movement of the eyes. The polarity of the signal is positive at the electrode to which the eye is moving.

IV. LITERATURE SURVEY

Various researcher studies show that electromyogram (EMG), the electro-oculogram (EOG), electrocardiography (ECG) and the electroencephalogram (EEG) can be used for different assistive and diagnosis applications. Several people are not able to do their daily activities due to disability. This leads to increase in researches in the field of assistive technology. Past years many researchers work in interactive devices to interact with computers, such as a keyboard or a mouse. In these cases, computer commands must be generated without using arms or hands, by using voice recognition [6], brain-computer interfaces (BCI) [5]–[6] or eye movements[8]- [12].

Electro-oculogram can be used for the study of the effects of the prolonged eye fixation; [6] author has proposed and discussed the method which analyses the alterations in autonomic responses due to prolonged eye gaze with the help of with electro-oculogram (EOG), electro-cardiogram (ECG), pulse plethysmogram (PPG) and electro-dermal activity (EDA). Author has suggested that the changes in autonomic responses with the mental effort produced by eye gaze were distinct and provides a good platform for the development of Man Machin Interface. EEG with EOG can also be other way of communication channel for mouse control along with determination of subject's control state i.e. whether the EOG system works according to patients mind or just a misjudgment. But by using EOG along with EEG there is unnecessary increase in complications and time due to EEG judgment. [9][10]. Recently researchers proposed an approach of interface that allows people to interact with computers using their eye movements is presented as the eye movement is the easiest way of communication [9], Study and capturing of the Natural eye movement detection for assisting application for paralyzed patients with motor disorders. In order to detect eye movements, the system uses electro-oculography (EOG). EOG detects the eyes movement by measuring, through electrodes, the difference of potential between the cornea and the retina [5]. EOG has been used in previous works to interact with different devices. Considering the characteristics of EOG signals, EOG-based HCI systems have become more popular in recent years [14]–[16]. For instance the researchers used EOG to control a robot arm [19], guide a wheelchair [18], or a key- board [14]. Such a system provides both ease and communication for disabled people, particularly when there is some physical restriction that avoids them from using other Human Computer Interface. Some researchers work came with the problematic condition due to involuntary as well as voluntary blink signals, to overcome this problematic condition author proposed the new method by varying the position of the electrodes varying in position there is change in output voltage, difference between

involuntary as well as voluntary blink signals to remove effect of such false trigger [21] [13].

V. METEHDODOLOGY

While rotating eye ball, body decreases or increases the resistance near eye. This change in electric signals can be measured using electrodes, such as the dry silver-silver chloride electrodes. There were different types of electrode that could be used, such a needle type electrode which gets inserted into the skin under the eye, another electrode is a contact lens with an electrode imbedded into the contact, but both options are very expensive. Finally the electrodes are the surface electrodes which are both noninvasive and inexpensive and will work well for the purposes of EOG recordings. These electrodes were chosen with the concern of protecting the eyes from any shock. Thus, solid dry gelled electrodes were chosen over wet gel electrodes as a precautionary measure to prevent the gel from entering the eyes. In addition to these electrodes the acquisition and amplification circuit need to build, the processing is done with the help of microcontroller circuit. To overcome the effects of RF noise and electromagnetic interference, shielded wires were used to connect Ag/AgCl electrodes and data acquisition circuits. As shown in Fig 3.0 methodology consist of the instrumentation amplifier and filers stages, this can be implemented with the help of different RC filter stages so as to remove the noise. as the output is analog signal this is given to ADC circuit so as to convert it to digital signal

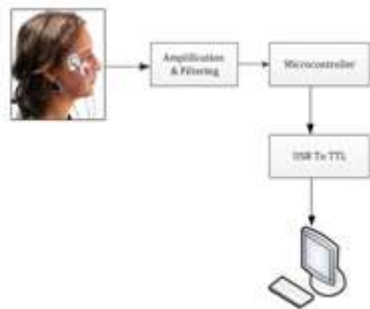

Fig. 4. Methodology for EOG signal analysis

In circuit, electrooculography signal can be obtained from one channel with three electrodes placed around the eyes; one of each electrode is term as a positive pole, negative pole and reference. Electro-oculography signal measurement process is shown in Fig. 5. It consists of three major parts: instrument amplifier, filters and signal conditioning amplifier processes. EOG signal of eye movement in horizontal direction is then detected with the help of, three major circuits and eye direction detection algorithm. As shown in the Fig 5 the instrumentation amplifier circuit is AD620 which is more advantageous than that of regular commercial op-amps. The

output is given to the filters so as to remove the noise as well as the unwanted signal spikes.

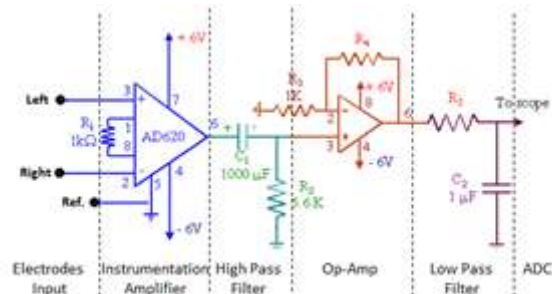

Fig. 5.Acquisition Circuit for Detection of Eye Movement

As the EOG signal frequency ranges from 0.01Hz to 10Hz,so it should be needed that the signal which will be processed through the circuit must be limited between this range, as a result the low pass filter will attenuates the frequency above 10 Hz while the high pass filter attenuates the signal below 0.01Hz,thus the LPF and HPF will reject the unwanted signals. As this output signal is used to process the system, this analog signal must be first converted to the digital one and then should be processed further for controlling the system connected next to it, thus it is then given to the ADC and then processed further for controlling action.

VI. CIRCUIT DESIGN AND IMPLEMENTATION

For the amplifier circuit we have used the AD620AN which offers the improved performance over the normal conventional three op-amp IA designs, along with fewer component, smaller size and lower power supply current. With auto gain /auto zero cycle which will removes all absolute accuracy & drift errors, whereas in conventional three op-amp IA design circuit, the input offset voltage & noise is been multiplied by $\sqrt{2}$ because of in three op-amp, two op-amp which serves as an input both will contributing to overall input error.

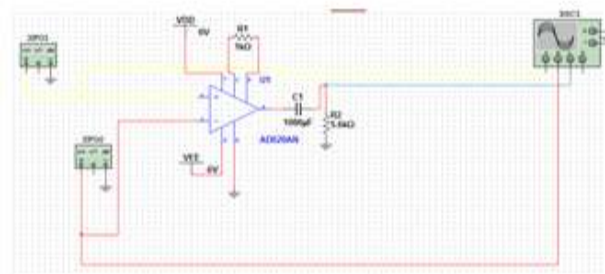
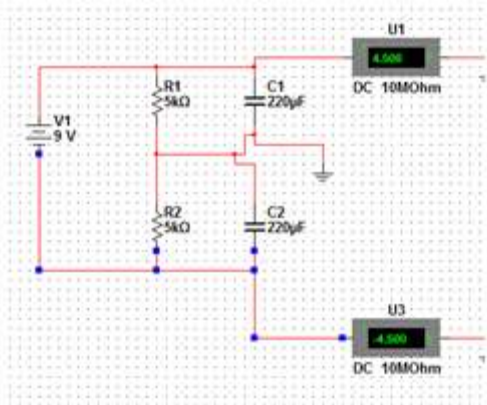

Fig.6. Schematic of AD620 Amplifier circuit

To obtain the supply there are different options such as make use of regulator ICs, combination of batteries etc. as shown in simulations results in fig.7. But as the hardware requirement is of bipolar 6V supply, it is suitable to make use of batteries than that of any regulator ICs and RC circuits. So to make it a

shock free circuit we make use of the eight 1.5V batteries as it is easily available in market



(a)

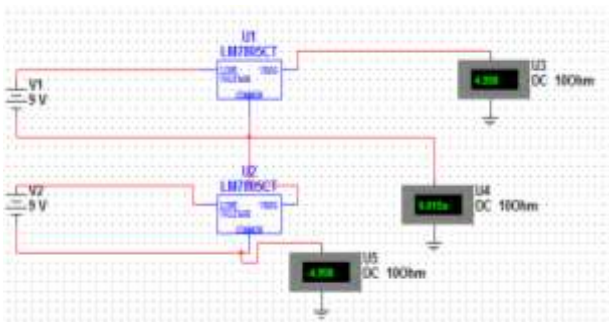

(b)

Fig. 7. (a) Bipolar power supply using regulator ICs (b) Bipolar power supply using Battery

VII. RESULT AND OUTCOME

As shown in the Fig.8 the mouse operation is controlled by the eye movement. When user will look straight the mouse will be in the steady position, whereas when the user will look towards right then the mouse will operate in the right direction and thus the cursor will moves towards right. Similarly when user will move eyes towards left directions the mouse will operates in the left direction and thus the cursor will moves towards left direction respectively. In this way the EOG signal can be used as an alternative assistive communication for Human Interfacing system for controlling the respected hardware connected to it.

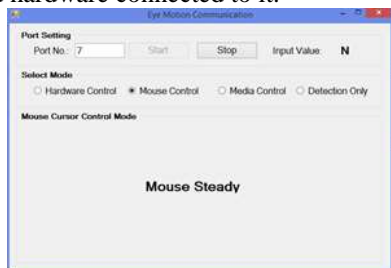

(a)



(b)

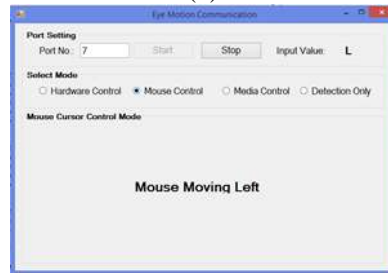

(c)

Fig. 8.(a) Mouse control using eye moment in steady condition (b) Mouse moving right (c) Mouse moving left

VIII. CONCLUSION AND SCOPE

Many researchers work has been done in the development of interactive device. Compared with the all studied process the electro-oculography offers the advantages as compared to EMG, EEG and ECG in terms of cost, linearity and ease of implementation. However, few researchers are developing a system which includes physical support of electrodes, electronics and the communications with the computer. A new device which comprises of dry EOG electrodes can be designed as a future work with the help of design using AD620 acquisition and filter circuit as discussed in the paper, making a step forward in the way to obtain a commercial EOG interactive device. The filter circuit can also be designed which will again improves and smoothen the results in order to provide accurate measurement for the analysis. Further improvements in the analysis were made by filtering the high frequency components and removing the power line noise. In future the commercial product can also be designed in order to operate any hardware or machine using the EOG signals using electrode sensors embedded and designed with the head belt. It can be used with wireless communication so as to make it as a real time and portable as well as user friendly product.

IX. REFERENCE

- [1] Ghedira S, Pino P, Bourhis G (2009), Conception and Experimentation of a Communication Device with Adaptive Scanning. ACM Trans Access Comput.
- [2] Arthi S V, Suresh R. Norman (2015), Analysis of Electrooculography signals for the Interface and Control of Appliances, International Journal of Multidisciplinary and Current Research ISSN: 2321-3124 2015.



- [3] Barea R, Boquete L, Mazo M, and Lopez E, (2002), Wheelchair guidance strategies using EOG, *J. Intell. Robot. Syst.*, vol. 34, pp. 279–299.
- [4] Dhillon H, Singla R, Rekhi N, and Jha R, (2009), EOG and EMG based virtual keyboard: A brain–computer interface, in *Proc. 2nd IEEE Int. Conf. Comput. Sci. Inf. Technol.*, pp. 259–262.
- [5] Deng L, Hsu C, Lin T, Tuan J and Chang S (2010), EOG based human-computer interface system development, *Expert Syst. Appl.*, vol. 37, pp. 3337–3343.
- [6] Perez-Vidal C, Carpintero E, Garcia-Aracil N, Sabater-Navarro J, Azorin J (2012), et al, Steps in the development of a robotic scrub nurse. *Robotics and Autonomous Systems* 60: Page No. 901–911.
- [7] Blasco JS, Iáñez E, Úbeda A, Azorín J (2012), Visual evoked potential-based brain-machine interface applications to assist disabled people. *Expert Systems with Applications* 39: Page No. 7908–7918.
- [8] Massaro D, Savazzi F, Di Dio C, Freedberg D, Gallese V, et al. (2012), When art moves the eyes: A behavioral and eye-tracking study.
- [9] Aggarwal Y, Singh N, Sinha R (2011), Electrooculogram based study to assess the effects of prolonged eye fixation on autonomic responses and its possible implication in man-machine interface, *IUPESM Springer-Verlag*
- [10] Yunjun N, Bonkon K, Andrzej C, Seungjin C (2014), GOM-Face: GKP, EOG, and EMG-Based Multimodal Interface With Application to Humanoid Robot Control, *IEEE TRANSACTIONS ON BIOMEDICAL ENGINEERING*.
- [11] Mingmin Y, Sou G, Hiroki T, Koichi T, (2013), Communication system using EOG for persons with disabilities and its judgment by EEG", *International Symposium on Artificial Life and Robotics, ISAROB, Springer*.
- [12] Rodriguez L, Ferrero F, Valledor M (2014), "Low-Cost System Based on Electro oculography for Communication of Disabled People", *IEEE International Journal SSD'14*.
- [13] Massaro D, Savazzi F, Di Dio C, Freedberg D, Gallese V, (2012) et al. When art moves the eyes: A behavioral and eye-tracking study.
- [14] V. Ciotti, (2010), 20 years of HCI," *Healthcare Informat.*, vol. 27, Page No. 64.
- [15] Gomez-Gil J, San-Jose-Gonzalez I, Nicolas-Alonso L, and Alonso-Garcia S (2011), "Steering a tractor by means of an EMG-based human-machine interface," *Sensors*, vol. 11, pp. 7110–7126.
- [16] Rezazadeh M, Firoozabadi S, Hu H, and Golpayegani H (2011), "A novel human–machine interface based on recognition of multi-channel facial bioelectric signals," *Austral. Phys. Eng. Sci. Med.*, vol. 34, pp. 497–513.
- [17] Tangsuksant W, Aekmunkhongpaisal C, Cambua P, Charoenpong T, Chanwimalueang T, (2012) Biomedical Engineering International Conference, Directional Eye Movement Detection System for Virtual Keyboard Controller, *IEEE, BMEiCON-2012*
- [18] Yamagishi K, Hori J, and Miyakawa M (2006) "Development of EOG-Based Communication System Controlled by Eight Directional Eye Movements", *Engineering in Medicine and Biology Society, EMBS'06, IEEE*.
- [19] Barea R, Boquete L, Mazo M, and Lopez E, (2002) System for assisted mobility using eye movements based on electrooculography, *IEEE Transactions on Neural Systems and Rehabilitation Engineering*.
- [20] Iáñez E, Úbeda A, Azorín JM, Perez-Vidal C (2010), "Assistive robot application based on an rfid control architecture and a wireless eog interface". *Robotics and Autonomous Systems* 60: 1069–1077.
- [21] Deotale T., Tupkar N, (2015), Electro-Oculography in the field of Assistive Interaction Communication", *International journal On Recent And Innovation Trends In Computing And Communication*, Volume 3, Issue 3, ISSN 2321-8169, 1153-1156.
- [22] Deotale T., Tupkar N. (2014), Review on Electro-Oculography for Alternate Assistive Interaction", *National Conference On VLSI Design, Embedded System And Signal Processing-14 (NCVDES-2014) Paper ID-86, ISBN No-978-93-5196-210-6*.

IJEAST

INTERNATIONAL JOURNAL
OF ENGINEERING APPLIED SCIENCE
AND TECHNOLOGY

ABOUT IJEAST

International Journal of Engineering Applied Science and Technology (IJEAST) is a peer-reviewed, open access journal that publishes high-quality research papers in the field of Engineering, Applied Science and Technology.

IJEAST aims to provide a platform for researchers, academicians, and professionals to share their innovative ideas, research findings, and practical experiences with the global scientific community.

FOCUS AREAS

- Engineering
- Applied Science
- Technology
- Innovation & Development
- Interdisciplinary Studies



PEER REVIEWED

All submissions are rigorously peer reviewed to ensure quality.



OPEN ACCESS

Free and unrestricted access to research for all.



GLOBAL REACH

Connecting researchers and professionals worldwide.



TIMELY PUBLICATION

We ensure a swift and efficient publication process.



For more information, visit our website
www.ijeast.com



INTERNATIONAL JOURNAL
OF ENGINEERING APPLIED SCIENCE
AND TECHNOLOGY

✉ editor@ijeast.com

🌐 www.ijeast.com

📍 India



2455-2143