



IJEAST

INTERNATIONAL JOURNAL
OF ENGINEERING APPLIED SCIENCE
AND TECHNOLOGY



VOLUME : 5 ISSUE : 5 Print / Issue Publication Date: 29-Nov-2020



ISSN : 2455-2143



DOI : 10.33564/IJEAST.2020.v05i05.038

Indexed In



WWW.IJEAST.COM

editor@ijeast.com



CIRCULAR AND NON-CIRCULAR SHAPED COMPOSITE COMPONENT OF FIBER REINFORCE EPOXY RESIN MATERIAL UNDER LOADING CONDITION

Mr.Ajinkya. A. Patil

Department of Mechanical Design Engineering,
RIT, Islampur, Maharashtra, India

M.M.Mirza

Department of Mechanical Engineering,
RIT, Islampur, Maharashtra, India

Abstract- This study analyzes filament wound glass-reinforced fiber (GRF) pipes made of E glass under the loading. A nice summary of the tube model's computation method shows that the strength theory described can be adapted to filament wounding elements with adequate reliability. In the present work, the composite tubes have been simulated Using the finite element approach in a compressive loading environment by using the ABAQUS 6.14 software package. A study of a laminate plate(block) result we can see that going with composite material is best for improving the overall performance of the product. We find that about a 30-40 % improvement over traditional aluminum used equipment. Study has been done over an standard circular shape, research is further extended for cylindrical component and non-circular component. The proposed research work has application sewage pipelines in which Fluid contains particles into that flowing fluid that required self-cleaning property.

Keywords: Composite materials, polymers, filament winding, pipe, numerical simulation, finite element method, fiber-reinforced polymer (FRP), glass-reinforced plastic (GRP).

I. INTRODUCTION

Composites are synthetic materials developed from two or more than two materials which exhibit better physical and chemical properties than the constituents available. Composite materials have interesting properties such as high strength to weight ratio, ability to bring tailor maid properties, good electrical and thermal properties compared to metals. A laminated composite material consists of an several numbers of layer, a composite is mixture consist of an matrix and fiber together form composite material. Each layer may have similar or dissimilar material properties with

different fiber orientations under varying stacking sequences used in the component. Laminated composite material can be used in various application as of aerospace industries, defense applications, marine applications, automobile parts, and many other industries.

The proposed composite is associated with FRC as reinforcing and lightweight material like aluminum inside to achieve better dimensional and geometric properties. Composite materials have a unique Prof. property that can replace standard construction materials.

II. LITERATURE REVIEW

Ma Quanjin et al [1] In this paper the design and optimization of a 3 axis filament winding machine are determining the various techniques for filament winding and methods are determined. This paper gives an idea of the wet wounding method. Wet winding involves the implication of the fiber in the resin, in a resin bath before being wound over the mandrel. The wounded parts is then allowed to cured form some time to obtain the finished part.

Jose Humberto S et al [2] determined, damage and failure inside the carbon fiber reinforced epoxy filament wound composite tubes were evaluated, which is helps to identify different failure modes and easy to find fractures in the composite.

Hocine et al [3] in this paper, an experimental and analytical investigation of a storage vessel, made of a carbon/epoxy envelope coated on a metal liner vessel reinforced by composite subjected to internal pressure loading is proposed. Here Three stacking sequences of the composite were studied on the effect of the winding angle to vessel behavior.

Alnefaie [4] developed an FEA model of delaminated fiber-reinforced composite plates to analyses their dynamics. Natural frequencies and modal displacements are calculated for various case studies for different dimensions and delamination



characteristics. Numerical results showed in paper are then good concession with available experimental data.

M. Sudheer et al [5] compare the computational results with analytical methods to determine the best elastic properties. They tell that the Epoxy/Glass composite is more effective when the load is applied along the fiber direction. The FEA predicted results are in good comparison with the results of analytical methods.

III. PROBLEM DEFINITION

The composite material is light in weight to most metals. Their lightweight can used for the application of whether self-cleaning in pipelines needed. we consider the pipe is non-circular in section.

IV. METHODOLOGY

This work is completed with using following action in plan. in redr to complete work and plan is as

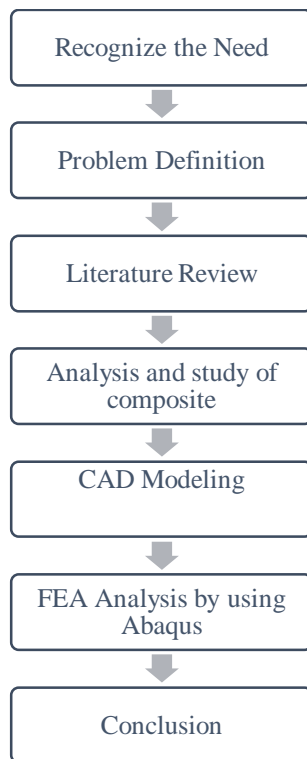

Fig. 1 Flow Chart of Methodology

Advantages of composites

- The tensile strength of an Composites are about four to five times, than that of steel.

- Composite materials are about 30- 45% lighter in weight than that of aluminum structures designed for same functional applications.
- Composites materials are less noisy while in working operations and also provide lower vibration produced as that of metal.
- Composites are mostly flexible than available metals and can able to convert to meet performance needed and if any complex design requirements are needed.
- Long-life of composite offers an excellent fatigue life , impact resistance, environmental resistance, and reduced maintenance, hence averall maintance cost is reduced.

Factors that contribue to the mechanical performance of a composite are:

- Length: The fibers can be available in any lenth from very long to short. An long continuous fibers are easy to produce and and gives good orientation in fiber but short fibers can-not be control properly in orientation during formation. Long fibers may provide many benefits over short fibers in most of times.
- Orientation: Fibers oriented in an only one direction give very high stiffness and strength in that direction as compared to that of in different directions.
- Shape: It can form in any shap but mostly common shape used is circular or rectangular because handling and manufacturing of such is easy.
- Material: The material of an the fiber is directly proportional to the mechanical performance of an composite while in action. Fibers are generally expected to have high elastic modulus and strengths, Provides stability in impact

2.3. Laminated Composites

They are made with a binding number of layers of at least two different materials together. The pattern of various orientation inside in material fiber-reinforced composite layer, laminate is known as lamination scheme or stacking scheme. By lamination, one can achieve two constituent layers, to improve the material quality. Typical examples are bimetal, laminated glass, plastic-based laminates, and laminated fibrous composites, etc.

Hybrid composites are composites containing at least two distinct types of matrix or reinforcement. The matrix or reinforcement type can be illustrious by their properties such as an physical, mechanical, material , or

chemical composition present in it. hybrids have better flexibility as compared to the fiber-reinforced composites. Mechanical properties of an hybrid composite can easily varied by changing its volume ratio and stacking sequence of different layers in side composte while producing..

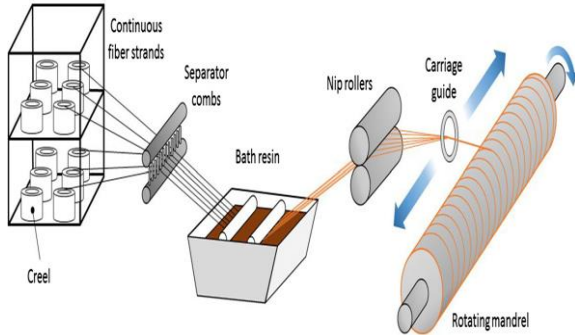

Fig. 2 Filament winging process

Filament winding is a process in which the continuous fibers are accurately positioned in an arranged pattern to form a cylindrical required shape. The above Figure shows a basic filament winding process. Several fiber rovings are pulled from a series of controlling the tension deep into a liquid resin bath that contains the resin itself, the hardeners, and the accelerators. At the end of the resin tank, the rovings are pulled through a nip roller where an excess resin is removed from the rovings. Then it passes through the carriage and is located on the mandrel. The speed of carriage and the winding speed of the mandrel is controlled to getting an proper winding angle pattern.

Winding parameters

The mathematical calculation should formulate for winding angle, which can refer to the winding pattern i.e. winding circuit. A method used to calculate winding angle is displacement calculation is be chosed to get an expected winding angle.

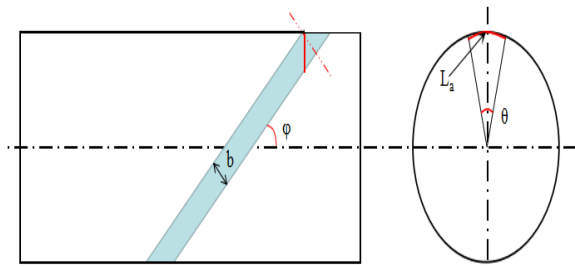

Fig.3 Filament winding parameter

Mandrel circumference $C_m = \pi \times d$

d = diameter of mandrel, b = width of fiber

Curve length $L_a = \frac{\text{width of mandrel (b)}}{\cos \varphi}$

φ = Winding angle

$$\text{Rotation angle } \Theta = \frac{360^\circ \times l_a}{C_m}$$

One circuit the rotation angle can = $\Theta \times 2$ for one complete rotation

$$\text{Circuit number } N_c: \frac{360^\circ}{2\Theta}$$

From this, we can calculate the number of circuits that are needed for an average winding of pattern i.e. cylinder. The theoretical knowledge of composite material

The volume fraction of fiber: It is the ratio of the volume of fiber to the volume of the composite.

The volume fraction of the matrix: It is the ratio of the volume of the matrix to the volume of the composite.

Let, v_m = volume of matrix,

v_f = volume of fiber, v_c = volume of composite

then we have $v_m + v_f = v_c$

We have, volume fraction of matrix + volume fraction of fiber = 1

V_T = Total volume

ρ = Density

m = Mass of fiber or resin.

W = Weight of resin or fiber

$$V_{\text{Total}} = V_{\text{Glass fiber}} + V_{\text{Resin}}$$

So for circular,

$$V_{\text{Total}} = \pi r^2 h$$

$$= \pi \times 25^2 \times 250$$

$$= 4.91 \times 10^5 \text{ mm}^3 = 490.87 \text{ cm}^3$$

Similarly, for elliptical shape,

$$V_{\text{Total}} = \pi abh$$

a = major axis = 25mm

b = minor axis = 15mm

h = length of cylindrical shape = 250mm

$$V_{\text{Total}} = \pi \times 25 \times 15 \times 250$$

$$= 2.9452 \text{ mm}^3 = 294.52 \text{ cm}^3$$

For Composition 40% fiber and 60% Resin.

$$\therefore V_f = 0.4 \times V_T = 0.4 \times 490.87 = 196.34 \text{ cm}^3$$

$$\therefore V_R = 0.6 \times V_T = 0.6 \times 490.87 = 294.52 \text{ cm}^3$$

$$\therefore \rho = \frac{m}{V}$$

$$\therefore m = \rho \times V.$$

For fiber,

$$\therefore m_f = \rho_f \times V_f,$$

$$\therefore m_C = 2.5 \times 196.34 = 490 \text{ gm.}$$

For resin,

$$\therefore m_R = \rho_R \times V_R$$

Laminate Code

A laminate is made of a group of single layers bonded to each other, each layer can identify by its location in laminate, material, and angle of orientation with respect to the reference axis, each lamina is represented by the angle of ply and separated from other plies. The first ply is known as top ply of

laminate over which second ply is wound and so on. This laminate code is plays important role in structure so that performance of composite changes.

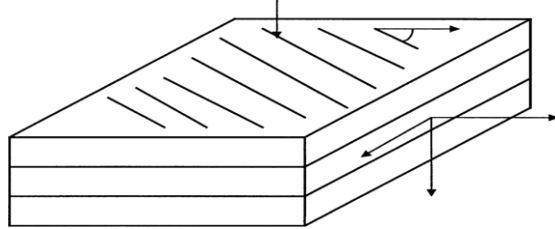

Fig. 4 Schematic of laminate

The laminate code [0/45/90/60/30] denotes the code for the laminate. It consists of five plies, each of them gives a different angle with a reference axis. The code indicates that each ply is made up of the same material and same thickness or of different. A notation of 0° would indicate the angle ply 45° is followed by 90° angle plies. in our case we consider as [0,45, -45,90,0].

Materials

Glass Fiber Fiberglass is material made up of extremely fine fibers of glass. It is used as a reinforcing agent for many polymer products, the resulting output of composite material, properly known as fiber-reinforced polymer (FRP) or glass-reinforced plastic (GRP), it is popularly known as "fiberglass".

Epoxy Resin The glue or resin or the resin matrix that binds everything together and supports as load transfer mechanism between fibers that are wound on the structure. Also, the resin matrix provides an corrosion resistance, protects fibers from the external damage, contributes overall composite toughness from surface impacts, cuts, abrasion, rough handling.

Epoxy (as a glue) is the most popular polymer matrix used.

Elastic property	Matrix material	Fiber material (Glass)
Young's modulus (E) in GPa	3.45	73.1
Poisson's ratio (ν)	0.35	0.22
Shear modulus (G) in GPa	1.28	29.95

Table 1: Material properties of Epoxy and fiberglass

V. DESIGN CONSIDERATION

Deformation in composite plate

For the analysis of laminated composite, we take aluminum and fiberglass block based on the above mentioned properties

A plate of 100×100 mm of aluminum and glass fiber layup is taken into account this is used for showing how deformation occurs in two different materials.

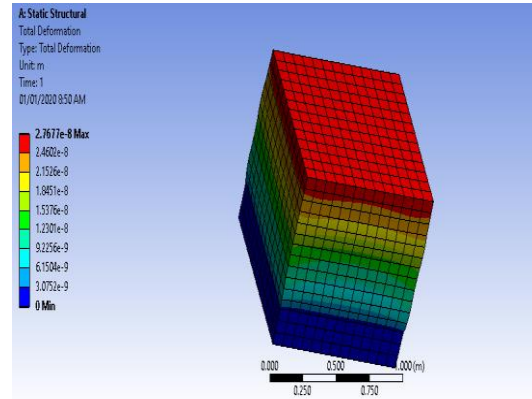

Fig 5 (a) aluminum sample

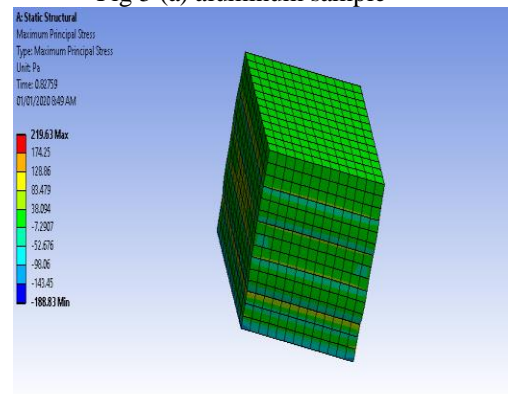

Fig 5 (b) Total deformation in a composite sample

Compared result between aluminum and composite layered block plate

Here the Computation result based on ANSYS 16 software we clearly determine that there is less deformation in composite material than that of metal material so going with composite will helps to increase the weight to performance ratio of any equipment.

Material	Total deformation (mm)	Maximum Stresses (Pa)
Aluminum alloy	1.4101	24.294

Composite layer	2.7677	219.63
-----------------	--------	--------

Table 2: Comparison between composite and aluminum

Configurations of Composite Tubes

The composite material tube has a wide range of applications because of their property's high specific strength and high specific stiffness concerning their weight. Thin-walled tubular structures made of Glass /Epoxy composite material has taken attention in applications of high strength. Here the tube of a composite is chosen in an elliptical shape.

VI. FINITE ELEMENT ANALYSIS

Finite element analysis is defined as body or an structure in which the analysis to be carried out is subdivided into smaller numbers of elements of finite dimensions called finite elements. Then the body is considered as an assembly of various elements connected at vary large finite number of joints knoen as an "nodes". Numerical solution is complicated with an stress problems can now be obtained by using FEA methods. The best feature of the Finite Element Method is as any structure made out of any material subjected to any complex loads and boundary conditions can be analyzed easily.

FE Modelling of Composite Tube Structure Finite Element using ABAQUS

here we choose length = 100 mm, Internal radius = 48 mm, external radius = 50 mm made up of GFRP Composite lamina. And a static load of 100 magnitudes is applied at edge. For non-circular we choose ellipse with major axis= 25 mm, and minor axis=15mm.

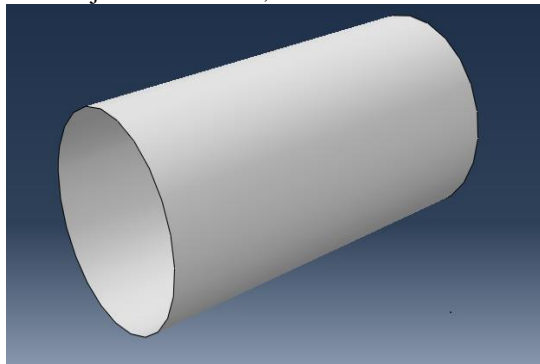

Fig 6 (a) GFRP Composite circular tube

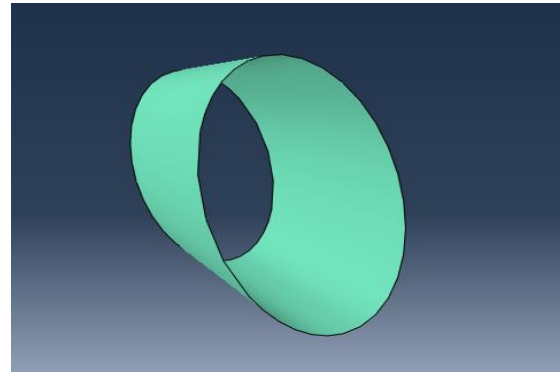

Fig. 6 (b) GFRP Composite non-circular tub

Laminate stacking sequence of ply in Abaqus.
Orientation insde laminate.

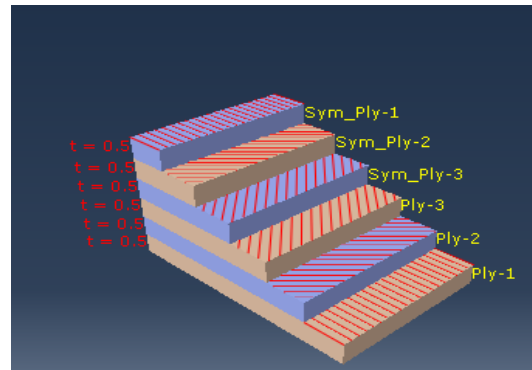

Fig 7(a) Laminate stacking sequence in a circular tube

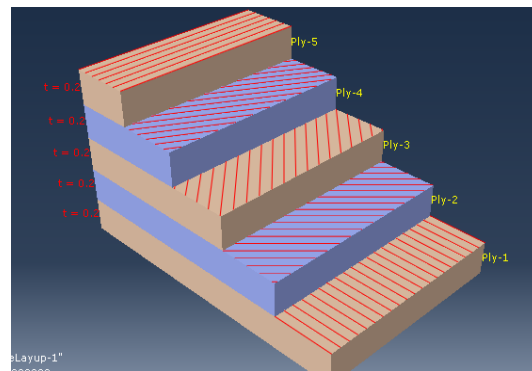

Fig. 7 (b) Laminate stacking sequence in non-circular tube

Laminate stacking sequence in circular and
Laminate matrix of epoxy /glass fiber in a circular and non-circular tube.

At the sides of tubes, an 100 N force is applied
That it may tension the cylindrical tube appears and thickness of 2mm.

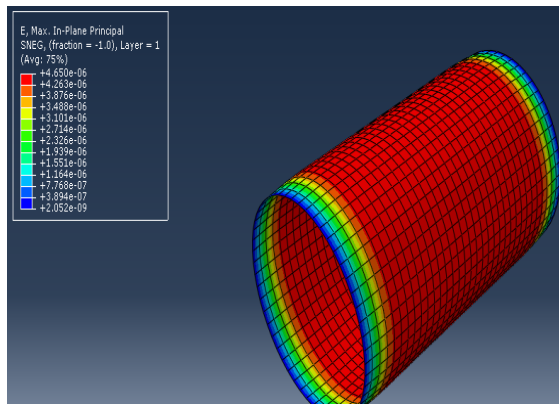

Fig 8 (a) circular shaped tube

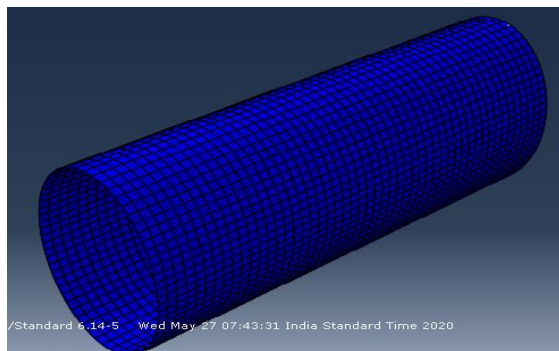

Fig 8 (b) Non-circular shape tube (elliptical)

VII. RESULT

Deformation stresses of GFRP Composite tube of circular and non-circular shape.

Material shape	Maximum Stresses (Pa)
Circular shaped	3.448 e05
Non-circular ellipse	0.285 e05

Table 3: stress in two shapes

VIII. CONCLUSION

We know that there is an improvement over the traditional shape. Therefore, by going with non-circular composite it will help in many more ways to improve the overall performance of the pipes. For a similar size model, choosing proper material as per required needed is more important and going with composite is one of the best options available this can improve performance to weight ratio of any equipment. This helps in designing the non-circular pipeline in the future for self-cleaning application.as a non-circular shape is more

self-cleaning than that of a proper circular section. therefore, a shape also plays important role in Deformation under compressive loading where for the non-circular shape it shows better withstand against loading.

IX. REFERENCES

- [1] Kabir, M.Z., Finite element analysis of composite pressure vessels with a load sharing metallic liner. *Composite Structures*, 49, (pp. 247-255) (2000).
- [2] M R M Rejab, Jiang Kaige, (2018). Filament winding technique: experiment, and simulation analysis on tubular structure”, IOP 2018 Conf. Ser.: Mater. Sci. Eng.
- [3] Kaw, Autar K. (2006). *Composite material: Mechanics of composite materials* 2nd ed. CRC Press 2006.
- [4] Karam Y. Maalawi., (2011). Use of material grading for enhanced buckling design of thin-walled composite rings/ long cylinders under external pressure” *Composite Structures* 93, (pp. 351 - 359).
- [5] Ma Quanjin, M.R.M. Rejab, Nallapaneni Manoj Kumar, M.S. Idris, (2019).
- [6] filament wonded machine: Experimental assessment of the 3 axis filament wonded machine performance, Published by Elsevier B.V. *Results in Engineering* 2 100017.
- [7] Jingzhong Xing, Pei Geng, Tao Yang, (2015). Stress and deformation of multiple winding angle hybrid filament-wound thick cylinder under axial loading and internal and external pressure, *Composite Structures* (pp. 868 – 877).
- [8] K. Alnefaie, (2009) . *Composite Structures: Finite element modeling of composite plates with internal delamination* . (pp. 21 – 27) 2009.
- [9] A. Hocine, D. Chapelle, M.L. Boubakar, Benamar, A. Bezazi, (2009) Experimental and analytical investigation of the cylindrical part of a metallic vessel reinforced by filament winding while submitted to internal pressure, *International Journal of Pressure Vessels and Piping* 86 (pp. 649–655).

IJEAST

INTERNATIONAL JOURNAL
OF ENGINEERING APPLIED SCIENCE
AND TECHNOLOGY

ABOUT IJEAST

International Journal of Engineering Applied Science and Technology (IJEAST) is a peer-reviewed, open access journal that publishes high-quality research papers in the field of Engineering, Applied Science and Technology.

IJEAST aims to provide a platform for researchers, academicians, and professionals to share their innovative ideas, research findings, and practical experiences with the global scientific community.

FOCUS AREAS

- Engineering
- Applied Science
- Technology
- Innovation & Development
- Interdisciplinary Studies



PEER REVIEWED

All submissions are rigorously peer reviewed to ensure quality.



OPEN ACCESS

Free and unrestricted access to research for all.



GLOBAL REACH

Connecting researchers and professionals worldwide.



TIMELY PUBLICATION

We ensure a swift and efficient publication process.



For more information, visit our website

www.ijeast.com



INTERNATIONAL JOURNAL
OF ENGINEERING APPLIED SCIENCE
AND TECHNOLOGY

✉ editor@ijeast.com

🌐 www.ijeast.com

📍 India



2455-2143