



IJEAST

INTERNATIONAL JOURNAL
OF ENGINEERING APPLIED SCIENCE
AND TECHNOLOGY



VOLUME : 7 ISSUE : 04 Print / Issue Publication Date: 30-Sep-2022



ISSN : 2455-2143



DOI : 10.33564/IJEAST.2022.v07i04.032

Indexed In



WWW.IJEAST.COM

editor@ijeast.com



SVM MODEL FOR PREDICTION OF ELECTROCHEMICAL DIAMOND DRILLING RESPONSE PARAMETERS

Mayank Shekhar, Dr. Sanjeev Kumar Singh Yadav
Department of Mechanical Engg.
HBTU, Kanpur, U.P, India

Abstract— Machining of advanced materials is difficult with traditional machining methods so the development of new and hybrid nontraditional machining processes is being done. These hybrid processes have complex machining process parameters and optimization of these is very necessary for better machining characteristics. Here a Support Vector Machine model is utilized to develop a prediction model for electrochemical diamond drilling process. The prediction accuracy achieved with SVM model was better than the developed quadratic regression model.

Keywords— ECDD process, SVM, MRR, Ra.

I. INTRODUCTION

Electrochemical Machining finds its wide applications in manufacturing industries. It is very useful for the machining of advanced materials where the traditional machining methods suffer to perform. ECM has the capability of machining various intricate shapes on hard-to-machine alloys. It works on the principle of Faraday's law where material removal occurs by anodic dissolution. As the ionic dissolution happens of anode or work piece there is no effect over the tool electrode and the work piece gets the same shape as that of the tool. This is similar to the electrolysis process and the flow of continuous electrolyte into the IEG helps in the removal of the precipitate left after anodic dissolution. This process is used as it machines the components without the formation of any burrs or residual stresses. Thus it helps in providing an economical and better solution for the machining of hard-to-machine materials which is not possible by the conventional machining processes. [1]

The performance of the process depends upon the input parameters like voltage applied, concentration of electrolyte, flow rate, feed rate (tool) etc. These parameters interact with themselves and influence the outputs i.e. MRR and Ra. These interactions can be studied with a suitable mathematical model based upon the observations recorded experimentally. Since the ECM process is very complex and the stochastic removal of material, it is essential to have an efficient model so that the response parameters can be accurately predicted so that the quality of the components machined is enhanced.

II. LITERATURE REVIEW

Researchers have widely worked upon diverse methodologies so as to predict the performance parameters for the ECM process with the investigation of the complex interactions among the independent parameters and dependent parameters. In [2] ANN based GRA method was used for optimal values of ECM process. With the MRR, Ra as the output parameters they concluded ANN model had good prediction capabilities of the response parameters.

An ANN model with back propagation was used in [3] to predict the output response i.e. MRR. In [4] researchers compared the response surface methodology model with the NSGA-II algorithm for the prediction of MRR and Ra responses resulting from ECM operation on super alloy. In [5] the researchers used a neuro-fuzzy inference model for MRR, Ra in ECM process. Differential evolution technique was used in [6] to explore the input parameter effects over MRR and Ra in ECM process. Researchers used ANN with back propagation and hidden neurons to develop prediction model for EDDCG process [7]. In [8] a perceptron model with multilayer was built with back propagation for the prediction of MRR in ECM process on aluminum alloy. The researchers have been modeling the ECM processing response surface methodology and other regression models with the optimization involving different evolutionary technique to find the optimal combination of machining conditions so as to get the enhanced performance.

Applications of ANN with back propagation algorithm have been largely proposed by past researchers. Very few applications of the use of support vector machines and other machine learning algorithms is present in literature. SVM with kernel function (Gaussian) was used for the prediction of wear rate of tool and processing time in micro-EDM process [9]. The application of SVM with radial basis function neural network was given in [10] for the quality prediction of wafers in the manufacturing of semiconductors. They claimed that SVM had better predictions as compared with RBFNN method. In [11] a least-square SVM model (LSSVM) was proposed with radial basis function to analyze the input parameters effect by electrochemical polishing on surface roughness of roller bearings. Based on the Mean-squared error values the multilayer feed forward NN and LSSVM



method was compared in [12] to find out the MRR and surface roughness values and it was concluded that LSSVM technique had better prediction accuracy.

Thus from the above it is evident that the statistical methods with ANN are very much suitable for modeling of the manufacturing processes having high complexity. In ECM process erratic behavior of the output responses can be perfectly modeled with some tolerance value using SVM. Thus here in this research SVM is used to predict the response of Electrochemical Diamond drilling process i.e. MRR, Ra with the input parameters as voltage, feed rate, tool RPM and electrolyte concentration. The performance of the SVM model is further validated with regression analysis using response surface methodology.

III. SUPPORT VECTOR MACHINE/REGRESSOR

Support Vector Machine is a modeling tool based upon the statistical theory and had been widely used for the regression, binary or multiclass classification, forecasting, pattern recognition and other tasks [13]. SVM had its concept coined by Vapnik [14] for the classification problem but later on was used also for regression problems with the help of loss function derived from the measure of distance from the target [15].

SVM involves the construction of the hyper plane so as to maximize the distance between the two marginal planes of the dataset which is mapped to other high dimensional space [14]. So as to find out the margin between the dataset, two marginal hyper planes are constructed each side of the hyper plane segregating the dataset. The marginal plane has to be placed at the maximum distance possible from the separating hyper plane. The larger the distance from the hyper plane the better is the classifier. SVM can be used with some parameters like regularization parameter, kernel and loss function etc. this helps it to be very helpful for use in manufacturing environments. Because of requirement of moderate size dataset SVM can be efficiently used in real world scenarios where the collection of large experimental data is difficult because of machining cost associated with the process.

The SVR or Support Vector Regress or works towards development of linear model when the input parameters are portraying to a high dimensional space with use of kernels. Let the sample of training data with the input features be $[(x_1, y_1), (x_2, y_2), \dots, (x_n, y_n)]$, used for development of model in a M - dimensional space. Let the train and test dataset be different and equally distributed. Here the aim is to develop a model using the input space which would be nearest to the targeted function value and the targeted function given is

$$f(x) = m \cdot x + c \quad (1)$$

Here (\cdot) gives the dot product and m and c are the vectors in the targeted function. Situation happens when the input parameters do not have linear relation with targeted function, and then it is mapped to the high dimensional feature space

$\phi(x_i)$ with the help of kernel functions. Various model developments involve fitting the data based upon lowest training error so as to get the weights associated with the training values.

Insensitive zone is implemented surrounding the estimated function values in SVR which considers the variation in the output. This parameter is given as ϵ and suggests the formation of an area with this radius around the values of estimated function which helps in ignoring the values having absolute error values lower compared to ϵ (threshold). This radius of formed area controls the learning process. With large radius, the model will be flat and would not be able to capture the variations in output. But with lower radius the model would turn out to be complex.

The vectors outside this area are called support vectors. When SVR is used for fitting model, a regularization parameter is used to give penalty to the support vectors and all the other points inside the insensitive area are relieved from any penalty. In SVR this ϵ -insensitive loss function is worked upon to minimize and perform the learning task and thus it regulates the accuracy achieved with the model. So for good fitting of model the selection of regularization constant (C), ϵ - insensitive zone radius, kernel function is very important. Let the loss function be given as $L(y)$ so as to hinder the overfitting of the model by giving penalty

$$L(y_i, f(x_i)) = \begin{cases} |y_i^{\text{experimental}} - f(x_i)| - \epsilon & \text{when } |y_i^{\text{experimental}} - f(x_i)| > \epsilon \\ |y_i^{\text{experimental}} - f(x_i)| & \text{when } |y_i^{\text{experimental}} - f(x_i)| \leq \epsilon \\ = 0 & \text{if } |y_i^{\text{experimental}} - f(x_i)| < \epsilon \end{cases} \quad (2)$$

The Kernel function $K(x_i, \mathbf{x})$ gives way for dimensionality reduction and helps in the reduction of the problem to a lower dimensional feature space. The Gaussian RBF with std deviation σ can be given as

$$K(x_i, \mathbf{x}) = e^{(-\|x_i - \mathbf{x}\|^2 / 2\sigma^2)} \quad (3)$$

Lagrange's multiplier (α_i, α_i^*) is used to solve this problem efficiently by the standard dualization principle. The useful support vectors are identified with the difference from these multipliers (α_i, α_i^*) . Points having zero values are the points under the ϵ - insensitive zone and points with non zero values indicates the elements outside the zone. Finally the weight vector can be given as [16, 17]

$$w = \sum_{i=1(1)N} (\alpha_i, \alpha_i^*) \phi(x_i) \quad (4)$$

And final model is given as

$$f(x) = \sum_{i=1(1)N} (\alpha_i, \alpha_i^*) K(x_i, \mathbf{x}) + b \quad \begin{cases} C_{\text{optimal}} \\ \epsilon_{\text{optimal}} \\ \sigma_{\text{optimal}} \end{cases} \quad (5)$$



IV. SVM FOR ECDD PROCESS

Electrochemical Diamond drilling process developed is a hybrid machining process involving the drilling as well as the mechanical grinding process. The tool here was so designed that it had an embankment of diamond abrasives which gave the effect of abrasion and the electrochemical process provided a better machining accuracy. The use of diamond abrasives over tool electrodes is well explained in [18]. The ECDD setup attachment was developed in house for the ECM machine Model: Electro M, (Metatech Industries ltd). The experiments with the ECDD tool were performed over Ti6Al4V samples of size (25*25*5) mm. The tool (304-Stainless steel) had a circular cross section of 8mm with a hole of 4mm in the center for electrolyte flow. The schematic diagram in figure 1 shows the developed setup and ECM machine. The response parameters of the experiments performed were MRR and Surface roughness (Ra), while the input parameters being voltage (V), Feed rate (mm/min), Electrolyte concentration (gm/l) and Tool rotation (RPM). The surface roughness values were calculated by handheld surface roughness tester by BanBros Model: TR-200 and the

rate of material removed was calculated by dividing the weight before and after machining with the time involved in machining i.e. (mg/min). The weights were measured with precision balance from Wensar Ltd. Model: PGB 200 with lowest count being 0.001gm. The MRR and Ra were calculated by averaging the three measured instances.

Table 1 gives the levels of input parameters for the experimental design using face centered CCD. Further the experiments were performed based on the design of experiments and response parameters were measured. The MRR is the quality characteristic which requires a maximum value with surface roughness Ra having a lower preferred value.

Parameter	Symbol	Unit	Level				
			- α	-1	0	+1	+ α
Voltage applied	A	V	11	13	15	17	19
Feed rate	B	mm/min	0.06	0.09	0.12	0.15	0.18
Electrolyte Concentration	C	g/l	200	225	250	275	300
Tool rotation	D	RPM	600	800	1000	1200	1400

Table1. Input parameters levels

The 30 experimental runs as given in table 2 are adopted to test the SVM model predictions, whereas another 500 experimental runs were simulated to train the SVM model.

The simulation of the runs was done in such a way that the process input parameters range was set between the levels as given in table 1.

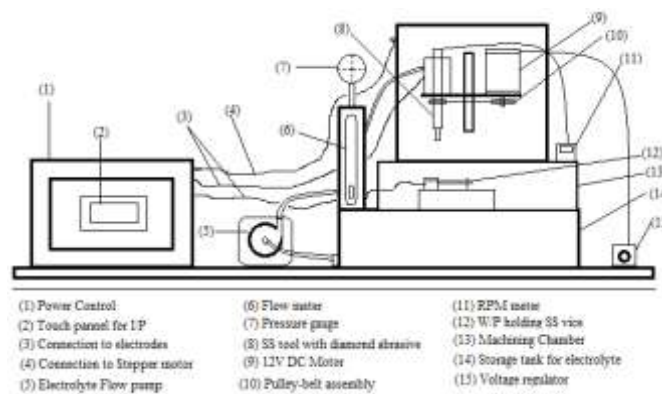

Fig.1 Schematic diagram of the ECDD process

The Python programming language was used for the development of the SVM model. Scikit-Learn provide the access to various machine learning algorithms including SVM. Other libraries used were Pandas, Numpy, Matplotlib and

Scipy. The selection of optimal values of (C), ϵ and (σ) has a major impact over the prediction done by the SVM model. The GRBF kernel function is employed here as it has a potential to cater to the needs of high dimensional input space



and also has the minimum number of hyper parameters which reduces the complexity of the model. With Grid Search CV the optimal values of the parameters were determined. Here the search space for parameter ϵ was taken between [0 1] and [1 100] for C. The Grid Search CV was provided with 10 k-

fold validation for the train dataset and the search was performed to optimize the parameters. Further the optimal parameter values were as given in table 3 and were used to develop the SVM model so that the accuracy of prediction can be validated.

Table2. Experimental results

Factors							Response						
Run	A	B	C	D	MRR	Ra	Run	A	B	C	D	MRR	Ra
1	19	0.12	250	1000	0.0539997	5.48	16	13	0.09	275	800	0.044632	4.26
2	13	0.09	225	1200	0.030256	4.12	17	13	0.15	275	800	0.03626	3.92
3	15	0.12	250	1000	0.034306	3.96	18	13	0.09	275	1200	0.03468	4.46
4	13	0.15	225	800	0.03439	3.16	19	17	0.09	275	1200	0.04496	4.98
5	15	0.12	200	1000	0.037684	3.82	20	15	0.12	250	1000	0.038654	3.93
6	13	0.09	225	800	0.032916	3.78	21	17	0.09	225	1200	0.041246	4.76
7	15	0.06	250	1000	0.035755	4.88	22	17	0.09	225	800	0.04073	4.72
8	13	0.15	225	1200	0.03528	4.16	23	17	0.15	225	800	0.0491514	4.18
9	15	0.12	250	1000	0.0416022	4.17	24	11	0.12	250	1000	0.0355325	3.87
10	15	0.12	250	1400	0.0418957	4.23	25	17	0.15	275	1200	0.05578	4.66
11	13	0.15	275	1200	0.03873	4.52	26	17	0.15	275	800	0.05162	4.53
12	15	0.12	250	600	0.0387618	3.86	27	15	0.12	250	1000	0.042568	3.92
13	17	0.09	275	800	0.045785	5.18	28	15	0.12	250	1000	0.035236	4.1
14	15	0.18	250	1000	0.0465118	3.92	29	15	0.12	300	1000	0.0429076	4.86
15	17	0.15	225	1200	0.052636	4.72	30	15	0.12	250	1000	0.040656	3.86

Table3. Optimal parameter values for SVM

Response	C	ϵ	σ
MRR	15	0.0536	0.006624
Ra	8	0.2436	0.5013

Further the validation of the developed model is done using the quadratic model equation developed using the Minitab software (version 18). The developed quadratic equation for MRR and Ra is given as below.

$$R_{MRR} = 0.038837 + 0.00548745 * A + 0.0025065 * B + 0.0019287 * C + 0.000181307 * D + 0.00214315 * AB - 0.000442402 * AC + 0.00103672 * AD - 0.000873527 * BC +$$

$$0.00149535 * BD - 0.000398598 * CD + 0.00151306 * A^2 + 0.000604887 * B^2 + 0.000395487 * C^2 + 0.000403724 * D^2$$

$$R_{Ra} = 3.99 + 0.357083 * A - 0.180417 * B + 0.207917 * C + 0.14125 * D - 0.043125 * AB - 0.060625 * AC - 0.101875 * AD - 0.005625 * BC + 0.118125 * BD - 0.074375 * CD +$$



$$0.174063 * A^2 + 0.105313 * B^2 + 0.0903125 * C^2 + 0.0165625 * D^2$$

From the equations it can be seen that Voltage, Feed rate and Electrolyte concentration had significant effect over the response parameters. Based on the developed regression model equation the values of the 30 experimental runs are calculated.

In table 4 and table 5 values of MRR and Ra are given as predicted by the quadratic and SVM model with the

experimentally calculated value. From the above predicted values it is suggested that the response predicted from the SVM model is closer to the values from the experiments performed as compared with the quadratic model. The R² and root mean square error was calculated for the different models and compared with the actual and SVM model. The SVM model had R² as 0.9635 and 0.9872 for MRR, Ra respectively with very low RMSE as 0.007635 whereas quadratic model had R² as 0.9239 and 0.9569 for MRR, Ra respectively.

Experiment no.	A	B	C	D	Experimental	Quadratic Regression	SVM
1	19	0.12	250	1000	0.0539997	0.0502345	0.05421
2	13	0.09	225	1200	0.030256	0.026543	0.029983
3	15	0.12	250	1000	0.034306	0.03628	0.03412
4	13	0.15	225	800	0.03439	0.03129	0.03511
5	15	0.12	200	1000	0.037684	0.03982	0.03698
6	13	0.09	225	800	0.032916	0.030126	0.03314
7	15	0.06	250	1000	0.035755	0.03269	0.03512
8	13	0.15	225	1200	0.03528	0.03763	0.03486
9	15	0.12	250	1000	0.0416022	0.04936	0.03859
10	15	0.12	250	1400	0.0418957	0.04863	0.04629
11	13	0.15	275	1200	0.03873	0.04125	0.04069
12	15	0.12	250	600	0.0387618	0.04066	0.03789
13	17	0.09	275	800	0.045785	0.05182	0.04836
14	15	0.18	250	1000	0.0465118	0.04239	0.04429
15	17	0.15	225	1200	0.052636	0.05792	0.05036
16	13	0.09	275	800	0.044632	0.04633	0.04298
17	13	0.15	275	800	0.03626	0.04039	0.03896
18	13	0.09	275	1200	0.03468	0.03862	0.03396
19	17	0.09	275	1200	0.04496	0.04892	0.04239
20	15	0.12	250	1000	0.038654	0.04239	0.04068
21	17	0.09	225	1200	0.041246	0.04568	0.04436
22	17	0.09	225	800	0.04073	0.04479	0.04368
23	17	0.15	225	800	0.0491514	0.05563	0.05362
24	11	0.12	250	1000	0.0355325	0.03269	0.03495
25	17	0.15	275	1200	0.05578	0.06138	0.05639
26	17	0.15	275	800	0.05162	0.05639	0.05345
27	15	0.12	250	1000	0.042568	0.04639	0.04169
28	15	0.12	250	1000	0.035236	0.03692	0.03598
29	15	0.12	300	1000	0.0429076	0.04862	0.04436
30	15	0.12	250	1000	0.040656	0.04329	0.04668

Table4. MRR values predicted from Quadratic and SVM

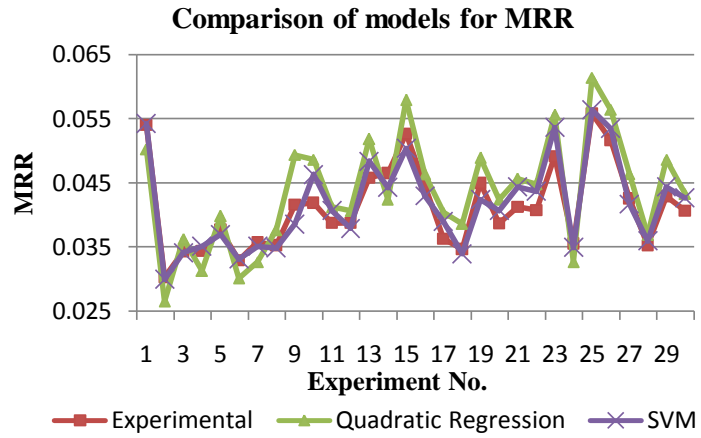

Fig. 2 Graph showing the different predicted values of MRR

The figure 2 and figure 3 gives the graphical relationship of experimental actual values and the values predicted from the quadratic as well as from the Support vector machine model. It can be inferred from the figure that the values predicted from the SVM model are much closer to the actual experimental values with minimum variation.

SVM is a proven technique for prediction use case and is being widely used in data mining problems. It is a better method to model the multi dimensional problems where conventional statistical methods fail. C , ϵ and σ are the three parameters which have to be optimally chosen for a robust model. Thus it can provide accurate predicted values devoid of any error arising from noisy dataset.

Table5. Predicted values of Ra with quadratic and SVM

Exp No.	A	B	C	D	Experimental	Quadratic	SVM
1	19	0.12	250	1000	5.48	6.01	5.56
2	13	0.09	225	1200	4.12	4.86	4.23
3	15	0.12	250	1000	3.96	4.52	4.12
4	13	0.15	225	800	3.16	3.98	3.37
5	15	0.12	200	1000	3.82	4.49	4.02
6	13	0.09	225	800	3.78	4.12	3.98
7	15	0.06	250	1000	4.88	5.02	4.78
8	13	0.15	225	1200	4.16	4.82	4.35
9	15	0.12	250	1000	4.17	4.68	4.09
10	15	0.12	250	1400	4.23	5.08	4.57
11	13	0.15	275	1200	4.52	4.86	4.63
12	15	0.12	250	600	3.86	4.47	4.05
13	17	0.09	275	800	5.18	5.68	4.92
14	15	0.18	250	1000	3.92	4.26	4.06
15	17	0.15	225	1200	4.72	5.12	4.97
16	13	0.09	275	800	4.26	4.73	4.38
17	13	0.15	275	800	3.92	4.58	4.07
18	13	0.09	275	1200	4.46	5.13	4.66
19	17	0.09	275	1200	4.98	5.65	5.28
20	15	0.12	250	1000	3.93	4.58	4.12
21	17	0.09	225	1200	4.76	5.34	4.92
22	17	0.09	225	800	4.72	5.26	4.96
23	17	0.15	225	800	4.18	4.86	4.47
24	11	0.12	250	1000	3.87	4.42	3.76
25	17	0.15	275	1200	4.66	5.34	4.93
26	17	0.15	275	800	4.53	5.16	4.72
27	15	0.12	250	1000	3.92	4.48	4.25
28	15	0.12	250	1000	4.1	4.86	4.32
29	15	0.12	300	1000	4.86	5.23	5.10
30	15	0.12	250	1000	3.86	4.35	3.98

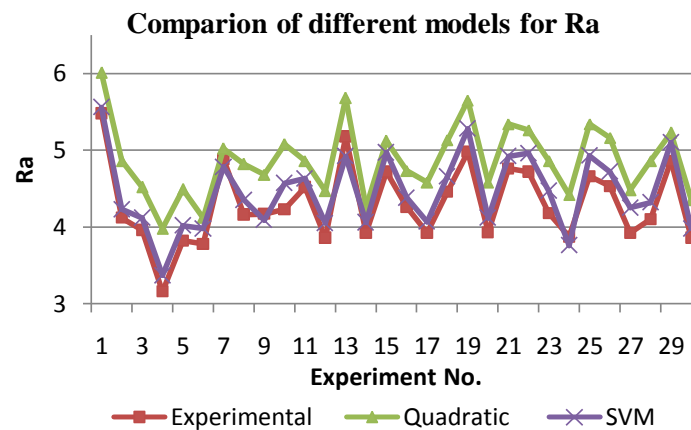

Fig.3 Graph showing the different predicted values of Ra

V. CONCLUSIONS

The present research deals with build out of a Support Vector regress or model for the prediction of Material removal rate (MRR) and Surface roughness (Ra), for an Electrochemical Diamond drilling process on Ti6Al4V alloy. The input parameters i.e. applied voltage (V), electrolyte concentration (gm/l), feed rate of tool (mm/min) and tool rotation (RPM) had a non linear effect over the response parameters MRR and Ra as the segregative diffusion of different phases of Ti6Al4V alloy. Thus here SVM with Gaussian RBF as kernel is used to reduce the dimensionality and achieve a better prediction model. The predicted values with the different model was compared and it was concluded based on the RMSE and R² values that the SVM model is good for the prediction of the response parameters.

VI. REFERENCE

- [1] H.A-G. El-Hofy, (2005), *Advanced Machining Processes- Nontraditional and Hybrid Machining Processes*, Mcgraw-Hill Education, USA,
- [2] Asokan, P., Ravi Kumar, R., Jeyapaul, R., & Santhi, M. (2008). Development of multi-objective optimization models for electrochemical machining process. *The International Journal of Advanced Manufacturing Technology*, 39(1), 55-63.
- [3] Kumar, K. S., & Sivasubramanian, R. (2011). Modeling of metal removal rate in machining of aluminum matrix composite using artificial neural network. *Journal of composite materials*, 45(22), 2309-2316.
- [4] Acharya, B. R., Mohanty, C. P., & Mahapatra, S. S. (2013). Multi-objective optimization of electrochemical machining of hardened steel using NSGAII. *Procedia Engineering*, 51, 554-560.
- [5] Teimouri, R., & Sohrabpoor, H. (2013). Application of adaptive neuro-fuzzy inference system and cuckoo optimization algorithm for analyzing electro chemical machining process. *Frontiers of Mechanical Engineering*, 8(4), 429-442.
- [6] Mehrvar, A., Basti, A., & Jamali, A. (2017). Optimization of electrochemical machining process parameters: Combining response surface methodology and differential evolution algorithm. *Proceedings of the Institution of Mechanical Engineers, Part E: Journal of Process Mechanical Engineering*, 231(6), 1114-1126.
- [7] Yadav, S. K. S., & Yadava, V. (2011). Neural network modelling and multi objective optimisation of electrical discharge diamond cut-off grinding (EDDCG). *International Journal of Abrasive Technology*, 4(4), 346-362.
- [8] Kasdekar, D. K., Parashar, V., & Arya, C. (2018). Artificial neural network models for the prediction of MRR in Electro-chemical machining. *Materials Today: Proceedings*, 5(1), 772-779.
- [9] Zhang, L., Jia, Z., Wang, F., & Liu, W. (2010). A hybrid model using supporting vector machine and multi-objective genetic algorithm for processing parameters optimization in micro-EDM. *The International Journal of Advanced Manufacturing Technology*, 51(5), 575-586.
- [10] Chou, P. H., Wu, M. J., & Chen, K. K. (2010). Integrating support vector machine and genetic algorithm to implement dynamic wafer quality prediction system. *Expert Systems with Applications*, 37(6), 4413-4424.
- [11] Xu, W., Wei, Z., Sun, J., Wei, L., & Yu, Z. (2012). Surface quality prediction and processing parameter determination in electrochemical mechanical polishing of bearing rollers. *The International Journal of Advanced Manufacturing Technology*, 63(1), 129-136.
- [12] Nayak, K. C., & Tripathy, R. K. (2012). Taguchi integrated least square support vector machine an alternative to artificial neural network analysis of electrochemical machining process. *IOSR J Mech Civ Eng*, 1, 01-10.



- [13] Deris, A. M., Zain, A. M., & Sallehuddin, R. (2011). Overview of support vector machine in modeling machining performances. *Procedia Engineering*, 24, 308-312.
- [14] Vapnik, V. N. (1995). *The nature of statistical learning theory*.
- [15] B. Scholkopf, J. Burges, A. Smolla, *Advances in Kernel Methods, Support Vector Machines*, Springer, Cambridge, 1999.
- [16] V.N.Vapnik, *Statistical learning theory*, John Wiley & Sons, New York, 1998.
- [17] Awad, M., & Khanna, R. (2015). *Efficient learning machines: theories, concepts, and applications for engineers and system designers* (p. 268). Springer nature.
- [18] Shekhar, M., & Yadav, S. K. S. (2020). Diamond abrasive based cutting tool for processing of advanced engineering materials: a review. *Materials Today: Proceedings*, 22, 3126-3135.

IJEAST

INTERNATIONAL JOURNAL
OF ENGINEERING APPLIED SCIENCE
AND TECHNOLOGY

ABOUT IJEAST

International Journal of Engineering Applied Science and Technology (IJEAST) is a peer-reviewed, open access journal that publishes high-quality research papers in the field of Engineering, Applied Science and Technology.

IJEAST aims to provide a platform for researchers, academicians, and professionals to share their innovative ideas, research findings, and practical experiences with the global scientific community.

FOCUS AREAS

- Engineering
- Applied Science
- Technology
- Innovation & Development
- Interdisciplinary Studies



PEER REVIEWED

All submissions are rigorously peer reviewed to ensure quality.



OPEN ACCESS

Free and unrestricted access to research for all.



GLOBAL REACH

Connecting researchers and professionals worldwide.



TIMELY PUBLICATION

We ensure a swift and efficient publication process.



For more information, visit our website
www.ijeast.com



INTERNATIONAL JOURNAL
OF ENGINEERING APPLIED SCIENCE
AND TECHNOLOGY

✉ editor@ijeast.com

🌐 www.ijeast.com

📍 India



2455-2143