



# IJEAST

INTERNATIONAL JOURNAL  
OF ENGINEERING APPLIED SCIENCE  
AND TECHNOLOGY



**VOLUME : 2    ISSUE : 5    Print / Issue Publication Date: 11-Aug-2017**



**ISSN : 2455-2143**



Indexed In



[WWW.IJEAST.COM](http://WWW.IJEAST.COM)

[editor@ijeast.com](mailto:editor@ijeast.com)



# CUSTOM MADE EMBEDDED AUTOMATION SYSTEMS FOR SMART HOMES – PART 1: PRELIMINARY STUDY

M. Papoutsidakis  
Dept. of Automation  
Engineering, Piraeus  
University A.S.,  
Athens, Greece

Rajneesh Tanwar  
Dept. of Information  
Technology,  
Amity University,  
Noida, India

Pooja Pant  
Dept. of Information  
Technology,  
Amity University,  
Noida, India

D. Tseles  
Dept. of Automation  
Engineering, Piraeus  
University A.S.,  
Athens, Greece

**Abstract—** With the passage of time along with the continuous development of technology, homes today could now provide safety, comfort and complete functionality of the site. The needs that were imposed by modern society coupled with the increasing demand for employment, have in effect reduced spare time to such a degree that it had to lead to the creation of automation for daily operations within the home where our physical presence may no longer be required. Therefore, it has become necessary to find a framework of procedures that is able to try and cover as much as possible the needs of people living within a residence. Through this effort developed the concept of the "smart home". The main factors leading to new automation technologies, constantly available on the market is the rise in living standards that generates new needs for comfort, quality and safety conditions in the workplace and residence. In Addition, the increase of the economic and environmental costs (greenhouse effect) of the consumption of natural energy sources that impose rational management and saving of energy of all kinds as well as the requirements (demands) for safety and reliability of electrical installations with potential future expansion and adaptation to rapidly changing needs and requirements (demands). This paper demonstrates the way all the above can be implemented in a modern residence.

**Keywords—** Smart home, Sensor Network, Embedded Solutions, and Microcontrollers Applications

## I. INTRODUCTION

It is a fact that the 20th century was the century that was marked by many achievements that changed the life of man. The discovery of electricity, the dissemination and its

installation changed forever the way cities and especially residencies function. [1] However, with the evolution and the combination of sectors of information technology, electronics and telecommunications household Automation could gain acceptance by users.

The final element that has played a significant role in the automation of household appliances was by adding control systems based on microprocessors which are accompanied by software. [2]

The advantages [3] [4] which offer smart houses relate:

- comfort
- energy saving
- economy
- safety
- ease of management
- benefits to the environment
- centralized management
- application integration
- decentralized system
- entertainment
- luxury

Determining factors on the type of installation required are separated into three categories: [5]

The first category is the PLC systems (Power Logic Controllers) which use part of the existing cabling in ready homes. The PLC were originally designed for industries, but because the design of a Smart Home requires efficiency, ease of installation and affordable price, it is chosen as an alternative.

The next category is the BUS technology which requires new wiring with cable Bus and that is the reason why it is selected mainly in a new plan and not the completed stage of construction thus increasing the time and cost of construction.



The third category is the RF systems where the number of wiring is small, since they usually exist independently upgrading and extending the system at any time. [6] Although the control is wireless with receivers for receiving RF signals. [7]

Remote control via Internet or telephone can be implemented in all three technologies mentioned above. [8]

To implement the interaction of individual parts of a smart home it was deemed necessary to create some standard situations. There are few accepted standards in the industry worldwide. [1] Some of the protocols, which are not all open, is the X10, C-Bus, EnOcean, 902 MHz in North America, KNX, INSTEON, Thread, Universal Powerline Bus and XPL.

The communication between devices is implemented by two kinds of networks. [9] The first network communication concerns the central link between the device and the remote user. Specifically, the communication network receives information from a gateway port and sends them to a back-end server which processes it and sends it via Internet to the central installation. Some networks are:

- The xDSL,
- the IEEE 802.11,
- local area networks (LAN)
- W-LAN
- WiMAX
- Gerna
- the UTRAN
- the GSM
- GPRS
- LTE

The second communication network connect the device and port.

Such networks are:

- Wireless
- the Zigbee
- the Z-Wave
- Bluetooth
- sensor networks etc.

IJEAST paper format font should be 10 in times new roman with single spacing. In recent years, the accessing of multimedia data or digital data has become very easy because of the fast development of the Internet. In other words, this development makes unauthorized distribution of multimedia data. For the protection of multimedia data, a solution known as watermarking is used. After the approximate 20 years' research, different kinds of watermarking algorithm based on different theory concepts were introduced [1-3]. A digital watermark encodes the owner's license information and embeds it into data. Watermarking may be used to identify the image of owners' license information and to track illegal copies.

The rest of the paper is organized as follows. Proposed embedding and extraction algorithms are explained in section II. Experimental results are presented in section III. Concluding remarks are given in section IV.

## II. SYSTEM DESCRIPTION

The system consists of custom designed software that is hosted and supported by the appropriate software. A brief summary of the equipment is provided below.

### A. Home LAN Network

The LANs (Local area Networks-LAN) is private networks used in homes or offices and generally on land of a few kilometers to link computers or workstations to factories and offices so to be able to share common resources, such as an Internet connection, the hard drive, the files, the folder of access and exchange information. [10]

In instances where control of the smart home relies on a network of computers, a wireless modem and an antenna are available so that the computer can communicate with other systems within walking distance.

### B. IP Protocol

IP Protocol (Internet Protocol) [12] is a single protocol that establishes the Internet so it can communicate with computers on the Internet. Access to information from one point of the planet to another is possible via this worldwide computers link. Every computer has a unique IP address in order to communicate when connected to a network. An example is shown here, 192.168.1.1. These addresses have the computers and devices in a smart home. In local area network LAN of the House each device must have a unique IP address.

### C. Sensors and microController

In our system we will use the Arduino Mega 2560 REV3. Which has an external power voltage 7-12V, 54 digital inputs/outputs and 16 analog. Within this board there will be an Ethernet Shield expansion card that provides the ability to control the controller from away. Through the Ethernet Shield, any compatible device can connect to the network using Ethernet cable. It has operating voltage 5V, like the Arduino Mega 2560 REV3 which can feed it, same voltage external power supply, communication speed 10/100 Mb, 14 digital inputs/outputs and 6 analog.

The LED RGB (Red-Green-Blue) has four terminals, where the three are Cathodes that control each color separately when connected to ground. The fourth terminal is the common Anode.



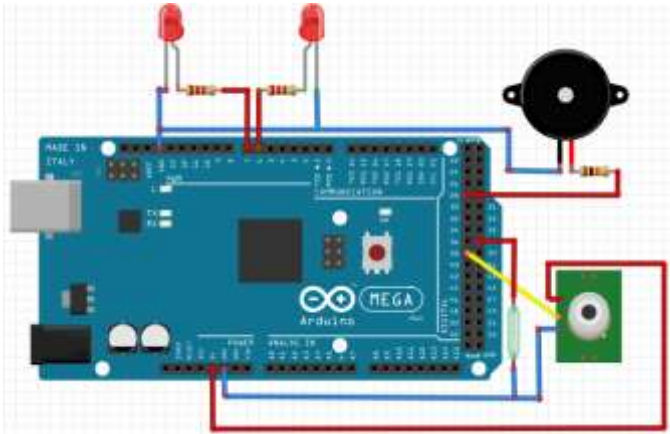

Figure 7: Connecting PIR, Buzzer, Magnetic Contact Switch to Arduino

The Photoresistor (Light Dependent Resistor – LDR) is a transducer for measuring the light radiation, with the resistance to vary inversely with the incident radiation.



Figure 8: Photoresistor

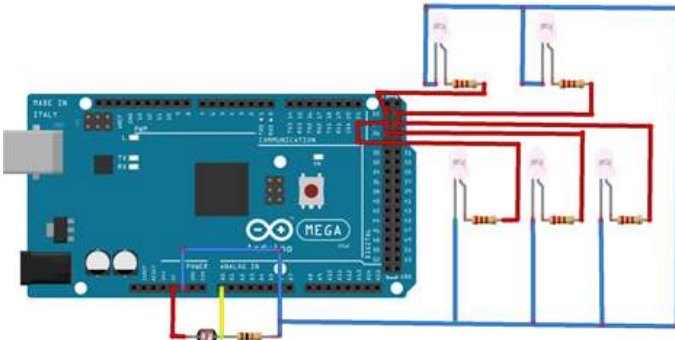

Figure 9: Connecting Photoresistor with Arduino

The Pressure switches create closed circuit only as pressed so as not to change the permanent status and affect the circuit.



Figure 10: Pressure switches

The potentiometer is a voltage divider that is used to control the electric potential, i.e. voltage.



Figure 11: Potentiometer

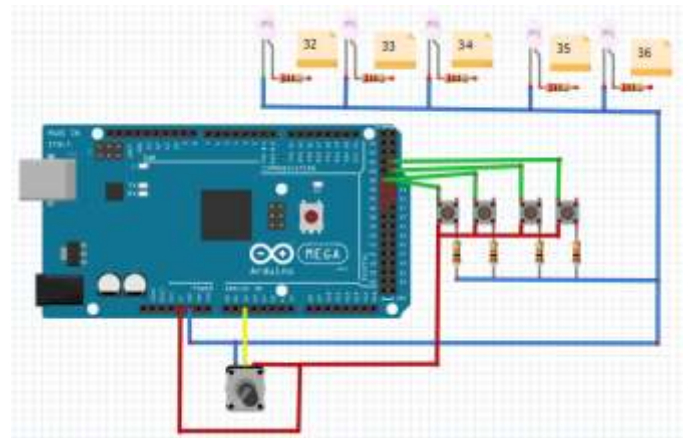

Figure 12: Connecting Pressure Switches to Arduino

Is a small electric instantaneous action switch. Two switches are used like terminals to the position of garage doors and stop the use of the servomotor.



Figure 13: Micro Mini Switch

The servomotors are used in speed and position to control the applications of both shaft and torque, i.e. they make it possible not only to regulate speed and engine speed but also the actual control of the position of the axis.

The Servomotor that was used fully rotating 360 ° with a speed of 110RPM (3.0 V), 130RPM (6V). Has voltage 4.8 V to 6V with analog control system.



Figure 14: Servomotor

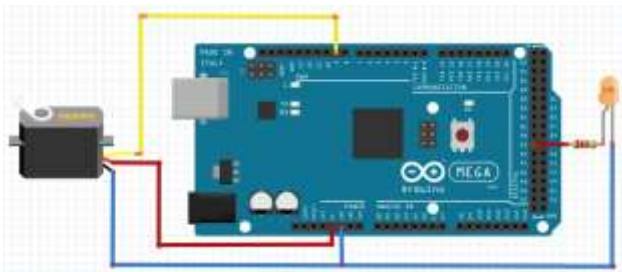

Figure 15: Connecting Servomotor with Arduino

The script function that will check the House implemented manually by using multiple buttons in a table format, placed in a specific part of the model as well as being controlled via mobile phone. So the construction emulate:

- the lighting in all rooms and outdoors. In an open space the lighting can be adjusted with a potentiometer,
- the water heater is without limitation by using a temperature probe and a Led with three different entries for each instance
- the alarm, for controlling violation of House, using magnetic contact in main entrance, motion sensor in an open space of the home and a buzzer for alarm,
- control of external lighting during the day, with the use of a Photo resistor
- and control of external garage doors using a servomotor.

### III. CONCLUSION

This first attempt to research the potentials to automate many home facilities was successful given the fact that all equipment was custom made with on the shelf electronics. There is another research work following this that is on the way to be presented that includes more sensors and moreover the necessary C code programming to make the whole system operative.

### IV. ACKNOWLEDGEMENTS

All authors would like to express their gratitude to the Piraeus University of Applied Sciences for providing the required data

and funding in order to undertake and complete this research project as part of “Automation of Production and Services” Postgraduate Program of Studies.

### V. REFERENCE

- [1] [https://en.wikipedia.org/wiki/Home\\_automation](https://en.wikipedia.org/wiki/Home_automation)
- [2] T. Joseph Lui, ‘Automation in Home Appliances: Automation in Home Appliances’, Part 1
- [3] <http://www.skyrodema.gr/index.php?lang=el&Itemid=10>
- [4] <http://alarmautomation.blogspot.gr/2011/10/homeautomation.html#.VtmhwGCLTIU>
- [5] <http://4myhouse.gr/Article.aspx?artid=27&catid=19&subcatid=134>
- [6] <http://www.eaton.eu/Europe/Electrical/ProductsServices/Residential/xComfort-RFSmartHomeSolutions/index.htm?wtredirect=www.eaton.eu/xcomfort>
- [7] <http://4myhouse.gr/Article.aspx?artid=27&catid=19&subcatid=134>
- [8] <http://exipnasistimata.gr/Content.php?PageId=130>
- [9] S.Fitilis, “Residence Automation with use of Raspberry Pi”, Doctoral Thesis, NTUA, 2013

# IJEAST

INTERNATIONAL JOURNAL  
OF ENGINEERING APPLIED SCIENCE  
AND TECHNOLOGY

## ABOUT IJEAST

International Journal of Engineering Applied Science and Technology (IJEAST) is a peer-reviewed, open access journal that publishes high-quality research papers in the field of Engineering, Applied Science and Technology.

IJEAST aims to provide a platform for researchers, academicians, and professionals to share their innovative ideas, research findings, and practical experiences with the global scientific community.

## FOCUS AREAS

- Engineering
- Applied Science
- Technology
- Innovation & Development
- Interdisciplinary Studies



### PEER REVIEWED

All submissions are rigorously peer reviewed to ensure quality.



### OPEN ACCESS

Free and unrestricted access to research for all.



### GLOBAL REACH

Connecting researchers and professionals worldwide.



### TIMELY PUBLICATION

We ensure a swift and efficient publication process.



For more information, visit our website  
[www.ijeast.com](http://www.ijeast.com)



INTERNATIONAL JOURNAL  
OF ENGINEERING APPLIED SCIENCE  
AND TECHNOLOGY

✉ [editor@ijeast.com](mailto:editor@ijeast.com)

🌐 [www.ijeast.com](http://www.ijeast.com)

📍 India



2455-2143