



IJEAST

INTERNATIONAL JOURNAL
OF ENGINEERING APPLIED SCIENCE
AND TECHNOLOGY



VOLUME : 1 ISSUE : 6 Print / Issue Publication Date: 09-Oct-2016



ISSN : 2455-2143



Indexed In



WWW.IJEAST.COM

editor@ijeast.com



BIOMETRIC ATTENDANCE SYSTEM CIRCUIT

Mohit Bais
Department of ECE
Dronacharya Group of
Institutions Greater Noida

Deeksha Rawat
Department of ECE
Dronacharya Group of
Institutions Greater Noida

PROF. Gunjeet Kaur
Department of ECE
Dronacharya Group of
Institutions Greater Noida

Abstract: In this paper, the proposed work provides the design method of portable biometric fingerprint based attendance system. This system includes terminal fingerprint acquisition module and attendance module. It can realize automatically several functions such as information acquisition of fingerprint, processing, and wireless transmission, fingerprint matching and making an attendance report. After taking the attendance, the system facilitates access to the attendance of a particular student in a particular class and can be used in many other fields like maintaining a criminal's attendance record, govt. and private offices etc. This system eliminates the need for maintaining the attendance in traditional way and reduces the manpower needed for the keeping of records.

Keywords: *Acquisition module, Biometric Fingerprint Identification, Finger module, Microcontroller, Max board*

I. INTRODUCTION

Fingerprint identification is one of the most well-known and common biometric identification system. Because of their uniqueness & consistency over time, fingerprints have been used for identification over a century, more recently becoming automated due to advancement in computing capabilities based on biological characters such as finger print, iris, facial recognition, etc. So, here we are using the fingerprint identification technique for maintaining the attendance record of people in an institution or an organisation.[1] We plan to maintain a record of the prints of the various students in the database, and they shall be matched and marked present when they swipe their fingerprints across the

scanner. Here, we are going to explain how to design the biometric attendance system circuit using AVR Microcontroller.

II. BACKGROUND

a) Biometric Attendance System Circuit Principle:

The main aim of this circuit is to take the attendance and display when requested. Fingerprint identification is because no two persons will have the same fingerprint in this world. This is because of the peculiar genetic code of DNA in each person. Fingerprint module differentiates between two fingers based on the ridges and valleys on fingerprint.[2] When the fingerprint is given it stores the points where there are changes in the direction of ridges and valleys using some algorithms. Inside the fingerprint module a Digital Signal Processor (DSP) is present to implement and analyse the algorithm. Main heart of the circuit is fingerprint module. This sends commands to the controller whenever fingerprint is matched. Microcontroller receives these commands from the fingerprint module and uses the internal EEPROM (Electrically Erasable Programmable Read Only Memory) to store the attendance. Keypad is used to send the requests to the controller to either enroll the new one or to save the attendance or to exit. LCD display displays the messages related to the commands received.[3]

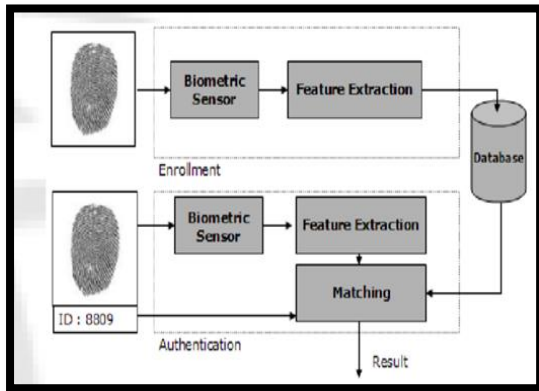

Figure 1: Block Diagram of Biometric[1] attendance system

b) Microcontroller

Microcontroller forms the backbone of the system. In this system P89V51RD2 microcontroller is used. It is an 80C51 microcontroller with 64 kB Flash and 1024 bytes of data RAM. It is also In-Application Programmable (IAP), allowing the Flash program memory to be reconfigured even while the application is running. It drives the control logic behind every functionality, some of which are mentioned below:

- Power up and initialize it and dependent modules.
- Check for interrupts, faults while the modules get initialised.
- Command the fingerprint module to function as requested by the software interface.
- Enable data transfer through the wireless module.

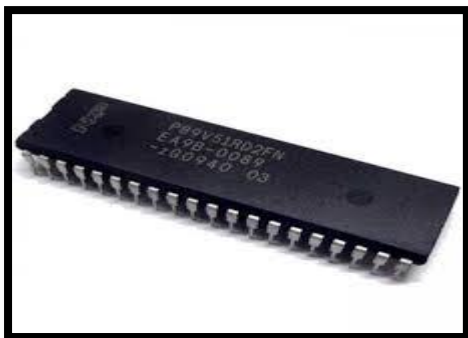

Figure2:P89V51RD2 microcontroller

c) Fingerprint module

Finger print sensor module with TTL UART (Universal Asynchronous Receiver/Transmitter) interface for direct connections to microcontroller UART or to PC through MAX232 / USB-Serial adapter is used. The user can store the finger print data in the module and can configure it in 1:1 or 1: N mode for identifying the person. The FP module can directly interface with 3v3 or 5v Microcontroller. A level converter (like MAX232) is required for interfacing with PC serial port. Optical biometric fingerprint reader with great features and can be embedded into a variety of end products, such as: access control, attendance, safety deposit box, car door locks etc.

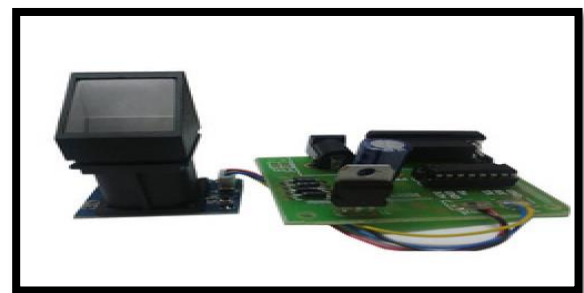
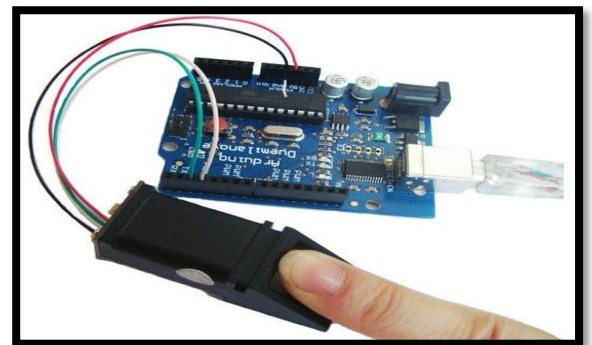

Figure 3: Fingerprint module

Specifications

- Fingerprint sensor type: Optical
- Sensor Life: 100 million times



- Static indicators: 15KVBacklight: bright green
- Interface: USB1.1/ UART (TTL logical level)
- RS232 communication baud rate: 4800BPS~115200BPS changeable
- Dimension: 55*32*21.5mm
- Image Capture Surface 15—18(mm)
- Verification Speed: 0.3 sec
- Resolution 500 DPI
- Voltage: 3.6-6.0 VDC
- Working current: Typical 90 mA, Peak 150mA
- Operating Environment Temperature: -20 to 45° centigrade

response byte is a single byte at 9600 bps thus making whole sensor very easy to use. We have provided indicating LEDs and function switch already so it is ready to use when you receive it. Just give power and start using the sensor using on board switches. Then you can move on making external application using these functions.

SYSTEM HARDWARE DESIGN

- AVR microcontroller development board
- Fingerprint module R305.
- Keypad (4*3)
- Atmega8 microcontroller
- RS232 Serial cable

Figure 4: Finger module using max232 board

III. PROPOSED WORK

The fingerprint sensor is combination of R305 FP+PIC MCU board that can read different fingerprints and store in its own flash memory. The sensor can perform three functions namely Add (Enroll), Empty Database or Search Database and return the ID of stored fingerprint.

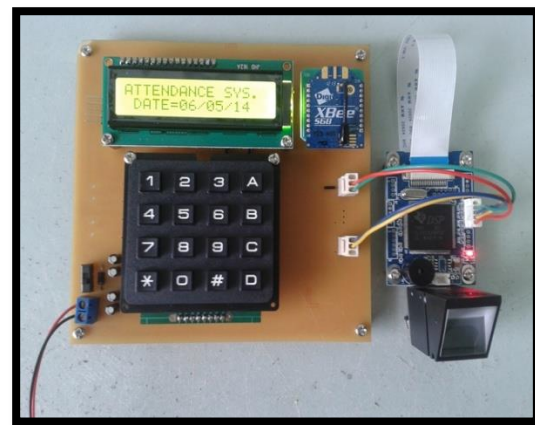

Figure 6: Snapshot of keyboard

- DC Battery or Adaptor (12V, 1Amp)
- 16*2 Alpha Numeric LCD
- Single pi connecting wires

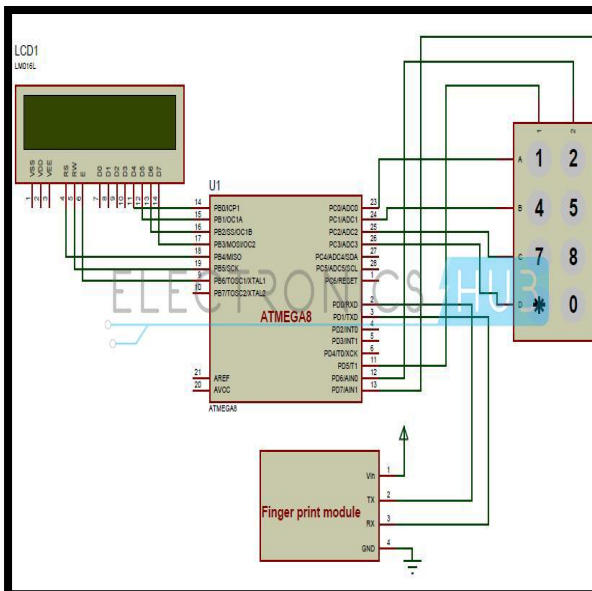

Figure 5: Biometric Attendance System Circuit Diagram

Any of three functions can be called simply by making the pin low of the sensor or pressing on-board three switches. The response is either error or ok, which is indicated by on-board LED. The response is also returned as single serial data byte. The return byte is a valid ID or error code. The

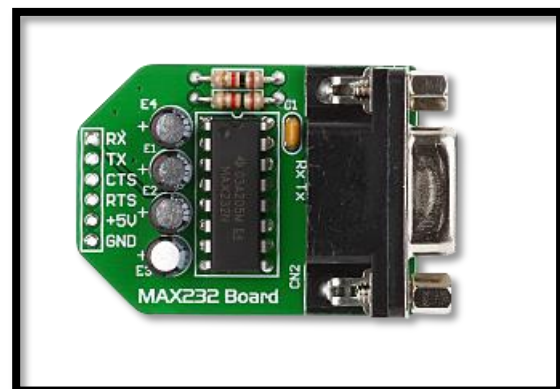

Figure 7: MAX 232 board[4]

The circuit in Figure 7 is needed to interface the fingerprint module to the PC. When a MAX232 IC receives a TTL level to convert, it changes a TTL Logic 0 to between +3 and +15 V, and changes

TTL Logic 1 to between -3 to -15 V, and vice versa for converting from RS232 to TTL. It operates at 5 Volt DC. There are always 4 capacitor with this IC, they are used as voltage multiplier.[6]

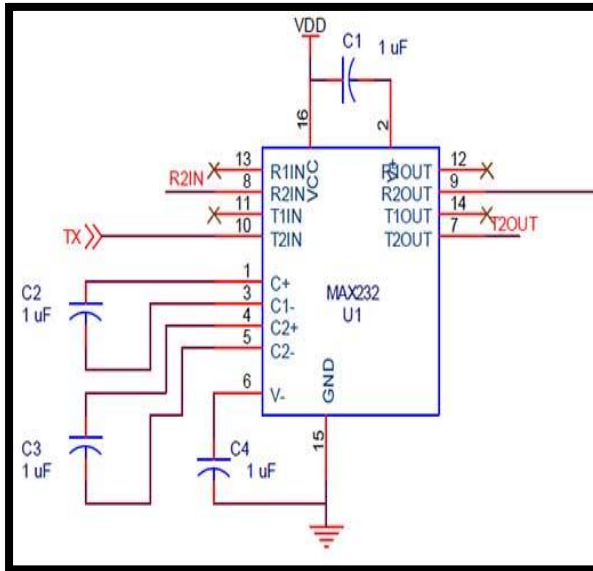

Figure 8: MAX 232 interface circuit

IV. BIOMETRIC ATTENDANCE SYSTEM CIRCUIT APPLICATIONS

- It can be used in educational institutions.
- Biometric attendance system can be used in industries.
- Biometrics can be used in ATM for authentication.
- Finger print authentication can be used in access control.
- Biometric Attendance system can be used in jail management to maintain the criminal attendance and records.

V. ADVANTAGES

- Very high accuracy and standardized
- It is the most economical biometric PC user authentication technique.
- Easy to use.[5]
- Small storage space is required for the biometric template, which reduces the size of the database memory required.

VI. CONCLUSION

The main purpose of this project is to monitor the student attendance in lecture, tutorial and laboratory sessions in more efficient way and send this attendance to their parents or maintain the record for staff or member in private and govt. offices. This system resists students from bunking classes through SMS sending feature to parents. Biometrics has been used effectively for more than a decade for time and attendance system. Fingerprint attendance system is a cost effective simplified system that uses fingerprints for identification. The fingerprint is unique to each individual and cannot be shared.

VII. FUTURE SCOPE:

If a student is regularly absent for a couple of days, then a message will be sent to his parents informing the issue through gsm technology. The system could be modified into a web based system so that reports could be generated anywhere. In an organisation, if a staff member is not present or does not come at proper time then no one can put his fake attendance. This technique can be very useful for maintaining the criminal attendance and record in jail and used in private and government offices.

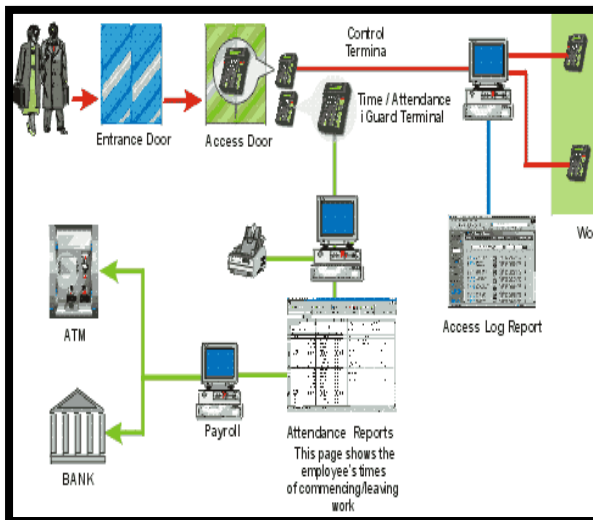

Figure 9: Biometric attendance system practical use [7]



VIII. REFERENCES:

- [1] Murizah Kassim, Hasbullah Mazian, Noriza Zaini, Muhammad Khidhir Salleh “Web based Student Attendance System using RFID Technology” , 2012, IEEE.
- [2]Li Jian-Po, ZHU XU-Ning,LI Xue, Zhang Zhi-Ming “Wireless Fingerprint Attendance System based on Zigbee technology” 2010 IEEE.
- [3]L.Rajeshkar,S.Vivek “Wireless fingerprint Attendance System using Zigbee Technology” IJPCSC(International Journal of Power Control Signal and Computation, volume-3,2012).
- [4] O. Shoewu, O.A. Idowu “Development of AttendanceManagement System using Biometrics” The Pacific Journal of Science and Technology, May 2012
- [5] Zatin Singhal, Rajneesh Kumar Gujral “Anytime Anywhere- Remote Monitoring of Attendance System based on RFID using GSM Network” International Journal of Computer Applications, February 2012
- [6] Mohamed Basheer K P, Raghu C V, “Fingerprint Attendance System for classroom needs”, NIT Calicut, Kerala, 2012
- [7] M.A. Meor Said, M.H. Misran, “Biometric attendance”, Universiti Teknikal Malaysia Melaka, Malaysia, 2014.
- [8] Tsai-Cheng Li1, Huan-Wen Wu, “Study of Biometrics Technology Applied in Attendance Management System”, Taiwan, 2012

IJEAST

INTERNATIONAL JOURNAL
OF ENGINEERING APPLIED SCIENCE
AND TECHNOLOGY

ABOUT IJEAST

International Journal of Engineering Applied Science and Technology (IJEAST) is a peer-reviewed, open access journal that publishes high-quality research papers in the field of Engineering, Applied Science and Technology.

IJEAST aims to provide a platform for researchers, academicians, and professionals to share their innovative ideas, research findings, and practical experiences with the global scientific community.

FOCUS AREAS

- Engineering
- Applied Science
- Technology
- Innovation & Development
- Interdisciplinary Studies



PEER REVIEWED

All submissions are rigorously peer reviewed to ensure quality.



OPEN ACCESS

Free and unrestricted access to research for all.



GLOBAL REACH

Connecting researchers and professionals worldwide.



TIMELY PUBLICATION

We ensure a swift and efficient publication process.



For more information, visit our website

www.ijeast.com



INTERNATIONAL JOURNAL
OF ENGINEERING APPLIED SCIENCE
AND TECHNOLOGY

✉ editor@ijeast.com

🌐 www.ijeast.com

📍 India



2455-2143