



IJEAST

INTERNATIONAL JOURNAL
OF ENGINEERING APPLIED SCIENCE
AND TECHNOLOGY



VOLUME : 7 ISSUE : 09 Print / Issue Publication Date: 09-Mar-2023



ISSN : 2455-2143



DOI : 10.33564/IJEAST.2023.v07i09.029

Indexed In



WWW.IJEAST.COM

editor@ijeast.com



A FULL DUPLEX 5G WIRELESS COMMUNICATION SYSTEM USING NI USRP 2944

Shyamala C
Associate Professor, Dept. of ECE
GSSSIETW, Mysuru.

Nithyashree L A
Assistant Professor, Dept. of ECE
GSSSIETW, Mysuru.

Sushma S J
Associate Professor, Dept. of ECE
GSSSIETW, Mysuru

Abstract— Full-duplex (FD) transmission is an emerging wireless technology that holds a great promise in improving the wireless throughput. The concept of full-duplex communication is simple. A single device can simultaneously transmit and receive on the same frequency channel. However, as the transmitted signal is many orders of magnitude stronger than the desired signal at the input of the receiver, it is extremely challenging to recover the desired signal and enable such a communication. In particular, the self-interfering (SI) signal needs to be suppressed by a factor of a billion to a trillion, requiring 90 – 120 dB of self-interference cancellation (SIC). Full-duplex wireless transceivers are typically operated over two concurrent half duplex channels, one for the transmitter (Tx) and one for the receiver (Rx). These half-duplex links have RF carriers separated in the frequency domain, namely using a TDD or Frequency Division Duplexing (FDD) scheme. This allows the receiver's sensitive front-end to be isolated from the high power generated by the co-located transmitter. In this paper, a full duplex communication system is implemented using Universal Software Radio Peripheral (USRP) and interfaced to a system installed with LabVIEW software. IQ signals transmission scenario was applied and tested.

Keywords—Duplex, Wireless communication, Channels, USRP, LabVIEW.

I. INTRODUCTION

Wireless Communication system refers to transfer of data or information from one location to the other in the absence of any electrical conductor between the two points. The medium

is usually air. Since, there exists no physical connection between the source and destination, ensuring that the data reaches reliably is a daunting task. Again, the communication can be carried out over short and long distances.

Moreover, the communication can be simplex or duplex. In simplex systems, the data transfer takes place in only one direction always. But, Duplex communication allows communication in both directions. It could be half duplex or full duplex. Half-duplex system indicates sending and receiving of information signals by both end nodes but only in one direction at a time. Half Duplex system can be seen in Walkie-Talkie etc. While in full duplex, the transfer of information happens in both directions and also simultaneously. A common Full Duplex system can be seen in our very own landline telephone networks, where both the parties can talk and listen at the same time. A full-duplex communication has numerous merits over half-duplex system. As the transfers in both directions are separated out, full transmission capacity is utilized in either direction. Also, collisions and contentions do not exist in full duplex, thereby waiting frames are not required. The segregation of communication in forward and reverse path is ensured by duplexing methods. Time division duplexing (TDD) and Frequency division duplexing (FDD) techniques are deployed for full duplex emulation.

Prototyping a wireless communication system and evaluating its performance is a challenging job. It includes several constraints and difficulties beyond those existing in other communication networks. Hence, designing an affordable real time wireless system and simulation a full duplex communication is exceedingly difficult. But rapid prototyping of wireless system is possible using NI USRP along with LabVIEW software.

National Instruments Universal Software Radio Peripheral (NI USRP) is a range of software defined radio. USRP as SDR (Software Defined Radio) is a flexible computer-hosted hardware platform which can be designed, tuned and deployed to mimic a communication system. As conveyed by the name, SDR is a radio in which most of the physical layer functions are software defined. By combining the NI USRP hardware with LabVIEW software, one can create a flexible and functional SDR platform for rapid prototyping of wireless signals including physical design, record and playback, signal intelligence, algorithm validation, and more.

Figure 1 below shows NI USRP 2944R. It is a 10 MHz to 6 GHz Reconfigurable USRP device. Built on the LabVIEW Reconfigurable I/O (RIO) architecture, USRP delivers an integrated hardware and software solution efficiently. A wide range of advanced research applications like multiple input multiple output (MIMO), spectrum sensing, synchronization of heterogeneous networks, transmission using various modulation methods, LTE relaying, WiFi Testbeds, RF compressive sampling, cognitive radio, beamforming, and direction finding can be realized using USRP-SDR.



Fig 1 NI USRP 2944R

The acronym for Laboratory Virtual Instrument Engineering Workbench is LabVIEW. It is a graphical programming language excellent for building complex applications. LabVIEW assists in visualizing every aspect of application, including hardware configuration, measurement data, and debugging. It provides extensive support for interfacing to devices, instruments, camera, and other devices. LabVIEW 2021 is used in this work to realize full duplex communication to transmit and receive signals along with NI USRP.

The remaining of the paper is organized as follows: Section II discusses various literatures related to the techniques used in this work. Section III covers the architecture and working details of NI USRP. The implementation of full duplex using USRP is discussed in Section IV. Section V presents the overall results and the discussion thereon. Section VI includes the conclusion.

II. RELATED LITERATURE

Various papers related to full-duplex wireless communication system, NI USRP and LabVIEW is discussed in this section. Tingjun Chen and Jin Zhou in their paper [1] present a practical real-time full-duplex wireless link consisting of two full-duplex transceivers. Full-duplex transceiver contains a RF self-interference canceller and Universal Software Radio Peripheral (USRP). The discrete-component-based RF self-interference canceller uses programmable band pass filters to achieve wideband cancellation through the technique of frequency domain equalization. This paper demonstrates self-interference suppression across the antenna, RF, and the digital domains through the NI LabVIEW interface. In this demonstration, a total amount of 95 dB SI suppression is achieved in practice, of which 50 dB is obtained by the circulator and the RF SI canceller across a 5 MHz bandwidth, and 45 dB is obtained by the digital SIC.

In [2], Nicole Grimwood and Rel Fogel demonstrated a real-time full-duplex wireless link. A pair of full-duplex transceivers performs simultaneous transmission and reception on the same frequency channel. A full-duplex transceiver is composed of a custom-designed small-form-factor analog self-interference canceller. A digital self-interference cancellation implementation is integrated with NI Universal Software Radio Peripheral (USRP). An adaptive analog self-interference canceller tuning mechanism adjusts to environmental changes. The practicality and robustness of the full-duplex wireless link is implemented through the LabVIEW interface. Desired signal under the powerful SI is obtained after demonstration.

Michael E. Knox in [3] explained a full duplex communication system using a common carrier operating with a single antenna resulting in high transmit to receive isolation and low insertion loss is presented. The technique provides over 40 dB isolation between the transmitter and receiver channels and 0.75dB insertion loss for the transmitter-to antenna and antenna-to-receiver paths.

Serkin F.B and Vazhenin N.A. in "USRP platform for communication systems research" 2019 [4] elaborated on the various features for design, testing and validation of different implementations of signal processing algorithms. In this research, Signal processing algorithms were realized using the concept of Software-Defined Radio (SDR), Model-Based Design and Universal Software Radio Peripheral (USRP) platform. According to the results of this work it can be concluded that the combined usage of these technologies is extremely user friendly and offers the potential to create more complex systems, including those containing soft-core processors, built-in FPGA, which allows to test and to prototyping the developed SoC-systems (System-on-Chip). Chance Elliott and Vipin Vijayakumar have published a paper on "National Instruments LabVIEW: A Programming Environment for Laboratory Automation and Measurement" 2018 [5]. Cytokinetics can be built and maintain an automation software infrastructure using NI LabVIEW. The

language has proven to be a powerful tool to create both rapid prototype applications as well as an entire framework for system integration and process execution. LabVIEW's strength in measurement instrumentation and seamless network communication protocols have allowed systems to be deployed containing multiple control computers linked only via the network. The language continues to evolve and improve as a general-purpose programming language and develop a broad user base.

Similarly, in [6], [7],[8] [11] work related to full duplex communication and implementation with SDR/USRP is dealt with. In [6], self -Interference cancellation attribute is focused. In [7] Light communication platform is realized with this scenario. In [8], Self Interference Cancellation is experimented

with OFDM system. While in [11], FSK Transceiver is explained. The architecture of USRP is extracted from [9] and its real time application is seen in [10]. In [12], Cognitive Radio is realized using SDR and LabVIEW.

III. NI USRP 2944R

The block diagram of NI USRP 2944 is shown in Fig 2 below. The block diagram shows DAC, ADC, up/ down converter, amplifier etc. Signals received by the USRP-2944 are amplified, down converted, filtered, digitized, and decimated before being passed to the host computer. Signals transmitted by the USRP-2944 are up sampled, reconstructed, filtered, upconverted, and amplified before being transmitted.

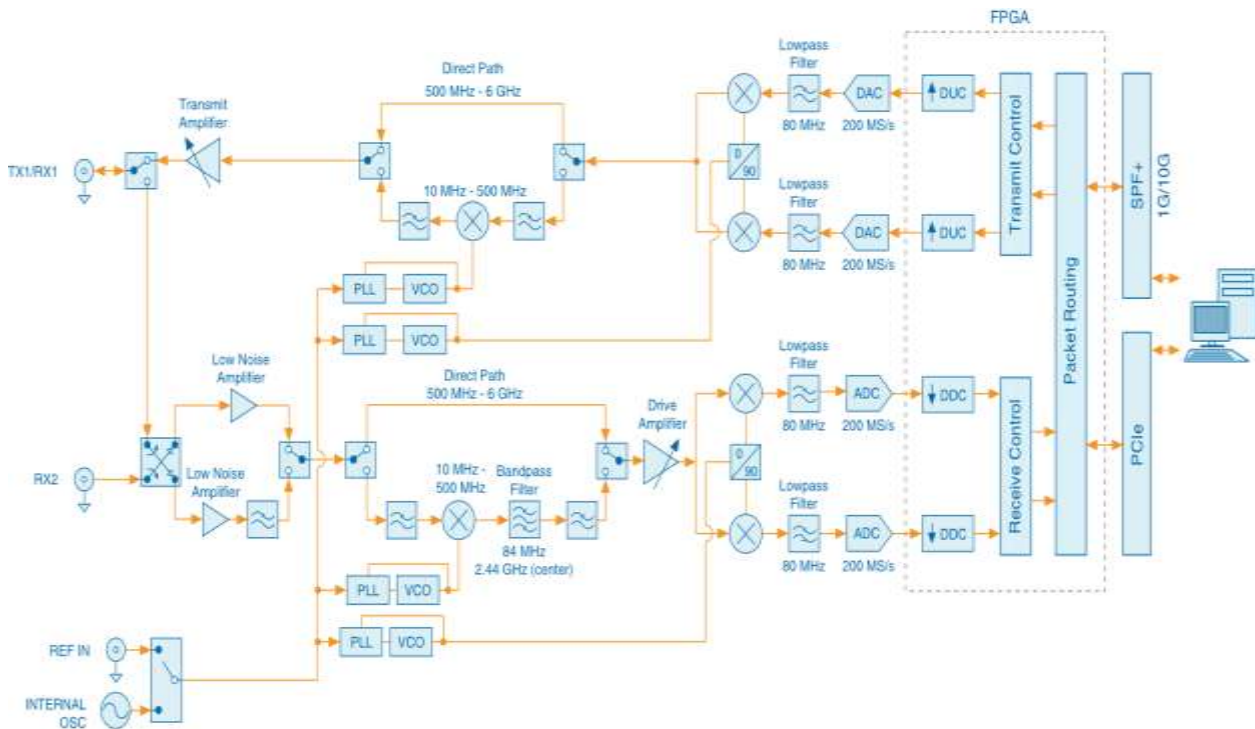

Fig 2 Block diagram of NI USRP 2944

The following steps describe the flow of information via individual blocks during receiving and transmitting.

Receiver path:

- Either a low-noise amplifier (LNA) or an LNA low-pass filter (LPF) combination amplifies the incoming signal, depending on the incoming frequency.
- The signal travels through either a direct conversion path or an up-conversion path, depending on the frequency.
- A final driver amplifier amplifies the signal.
- The phase-locked loop (PLL) controls the voltage-controlled oscillator (VCO) so that the device clocks and local oscillators (LO) can be frequency-locked to a reference signal.

- The mixer in the 10 MHz - 500 MHz path upconverts signals to 2.44 GHz.
- The bandpass filters limits signals in the 10 MHz - 500 MHz frequency range to 84 MHz of bandwidth.
- The quadrature mixers down convert the signals to the baseband in-phase (I) and quadrature-phase (Q) components.
- The lowpass filter reduces noise and high frequency components in the signal.
- The analog-to-digital converter (ADC) digitizes the I and Q data.
- The digital downconverter (DDC) mixes, filters, and decimates the signal to a user-specified rate.

- The down converted samples are transported to the host computer over a standard PCIe connection.

Transmitter path:

- The host computer synthesizes baseband I/Q signals and transmits the signals to the device over a standard PCIe connection.
- The digital upconverter (DUC) mixes, filters, and interpolates the signal to 400 MS/s.
- The digital-to-analog converter (DAC) converts the signal to analog.
- The lowpass filter reduces noise and high frequency components in the signal.
- The mixer upconverts the signals to a user-specified RF frequency.

- The PLL controls the VCO so that the device clocks and LO can be frequency-locked to a reference signal.
- The signal travels through either a direct conversion path or a down conversion path, depending on the frequency.
- The transmit amplifier amplifies the signal and transmits the signal through the antenna.

IV. FULL DUPLEX SYSTEM USING USRP 2944R

A single NI USRP 2944R was used to implement a full duplex wireless system and programmed using LabVIEW 2021. The screenshots of the various parts of the block diagram for the transmitter and receiver end from the VI files are shown in figures 3 to 10 below.

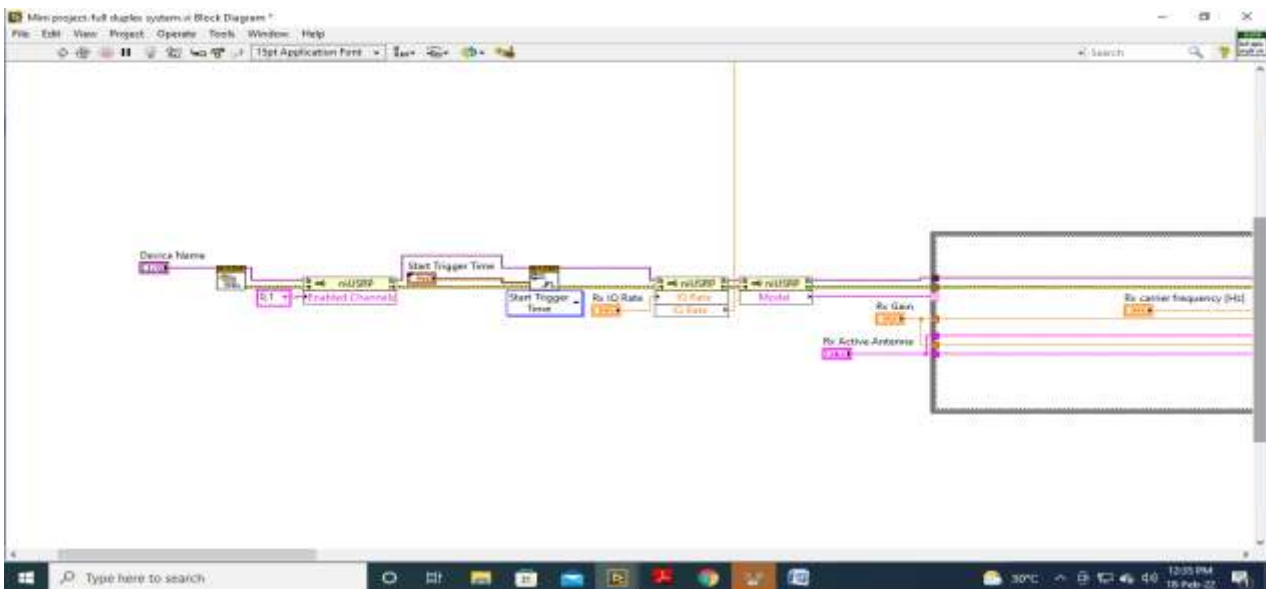

Fig 3 Block diagram to initialize Receiver

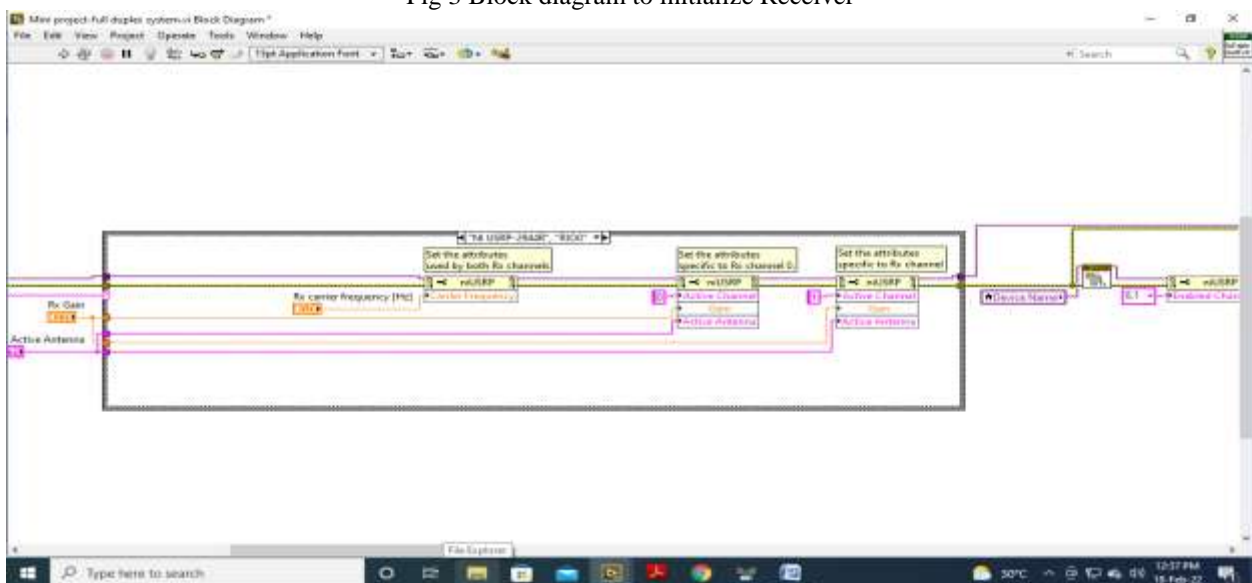

Fig 4 Block diagram to configure Receiver

In figure 4 the receiver parameters like Rx Gain, Active antenna, Rx carrier frequency are configured based on the scenario.

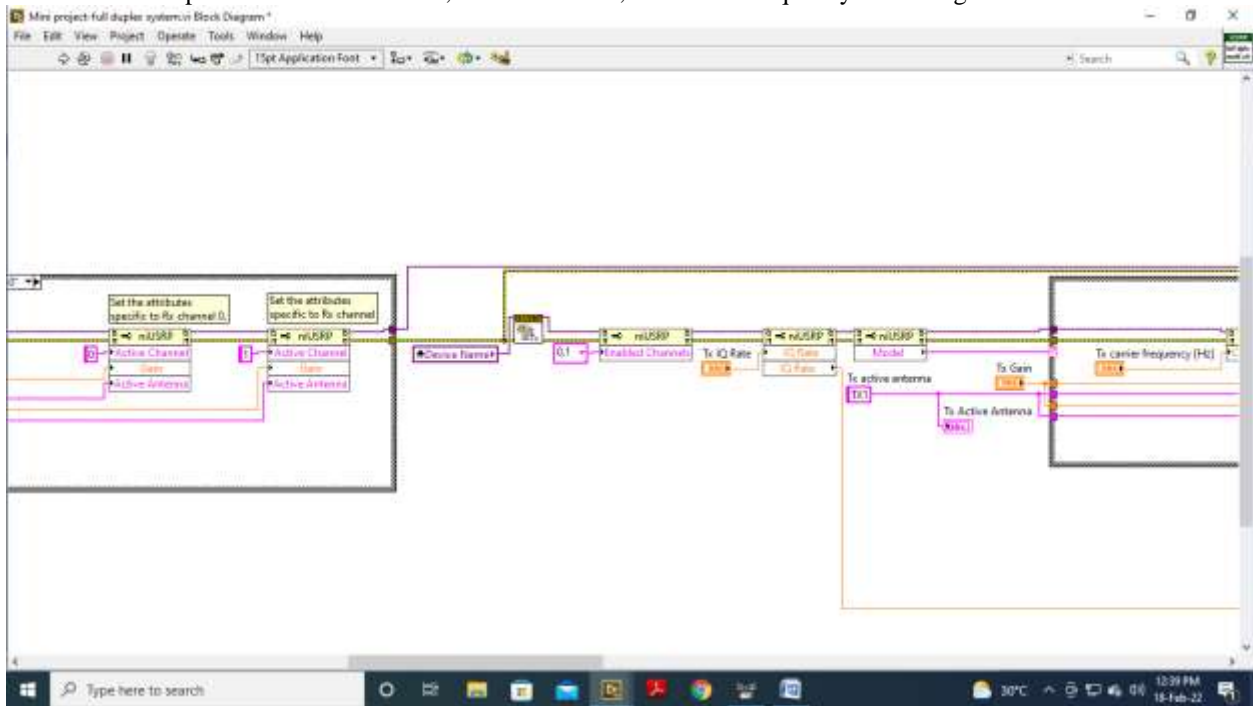

Fig 5 Block diagram to initialize Transmitter

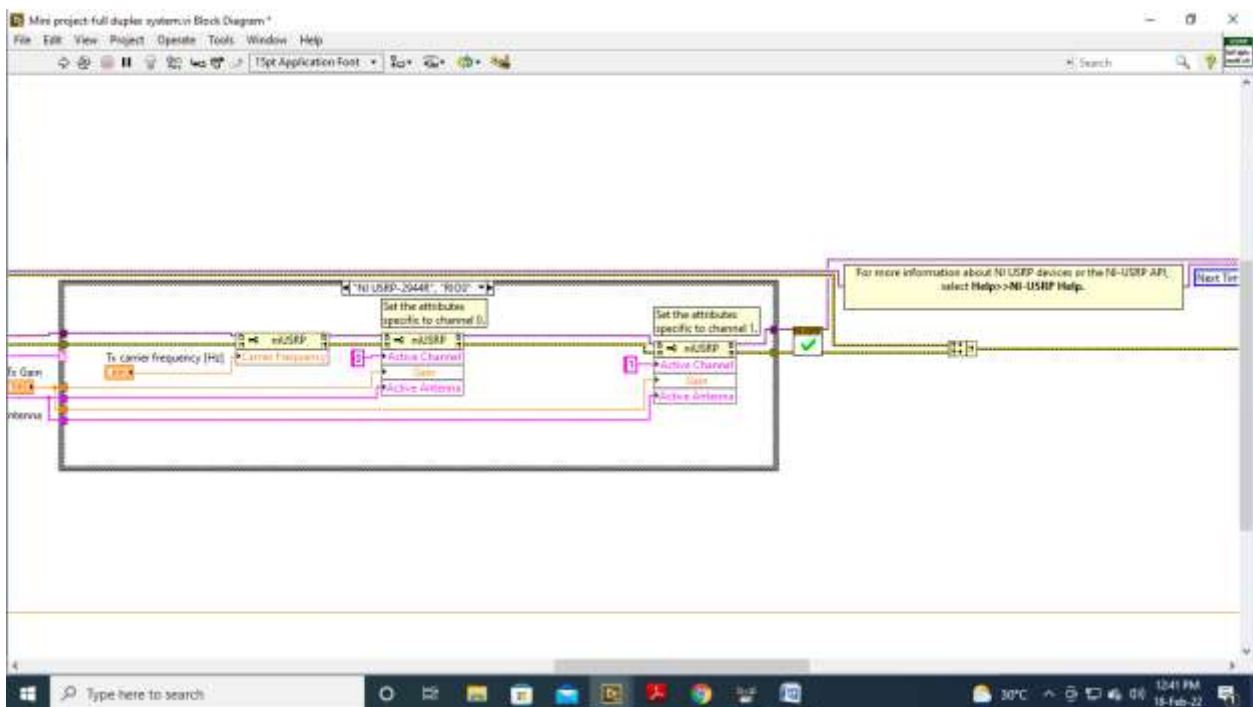

Fig 6 Block diagram to configure Transmitter

The transmitter is initialized and configured in the same way as receiver as shown in Fig 5 and 6. Next figure 7 shows the circuitry required for generating the message signal. As shown

in the block diagram, both in-phase and quadrature phase waveforms required for the dual channels (both channel 0 and channel 1) are generated.

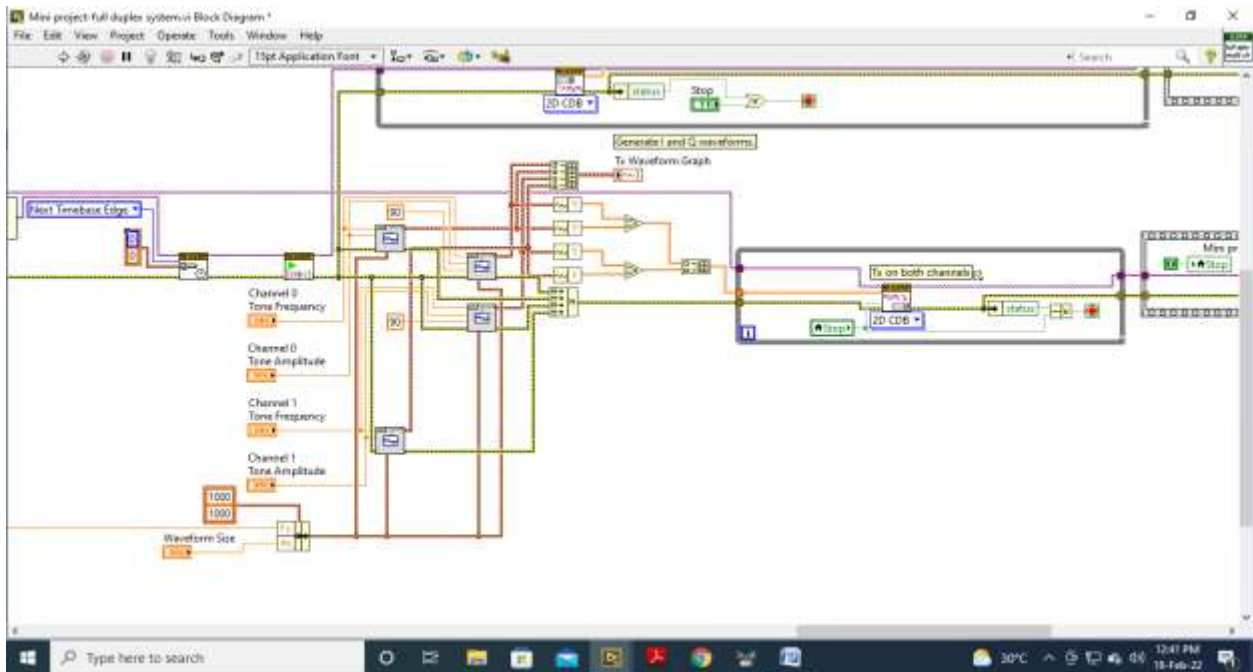

Fig 7 Block diagram to generate waveform

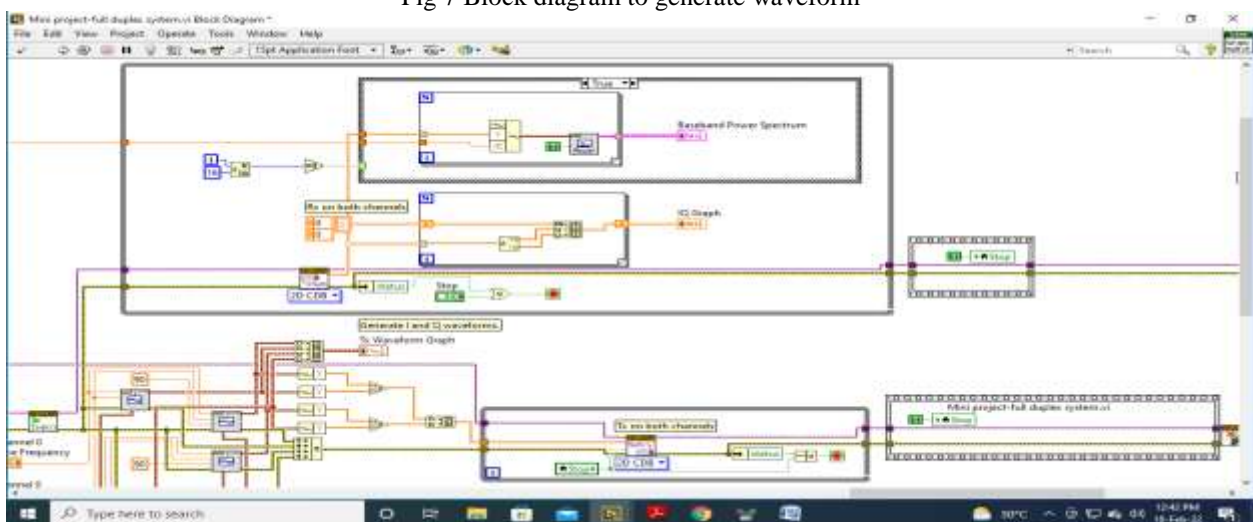

Fig 8 Block diagram to receive the signal

In Fig 8, two separate blocks are created to transmit and receive waveforms. Received signal is configured displayed both in time domain as well as in baseband power spectrum form.

The configurations used for the 2 channels are listed in below table:

Table 1 Configuration Parameters

Sl. No	Parameters	Values
1	Device Name	RIO0
2	Channel 0 Carrier Frequency	2GHz
3	Channel 1 Carrier Frequency	5GHz
4	IQ Rate	1MHz
5	Active Antenna	TX1,RX2 in both channels
6	Channel 0 Tone Frequency	10KHz
7	Channel 1 Tone Frequency	35KHz

V. RESULTS

The screenshots of results obtained on running the VI file are shown below in figures 9 to 11.

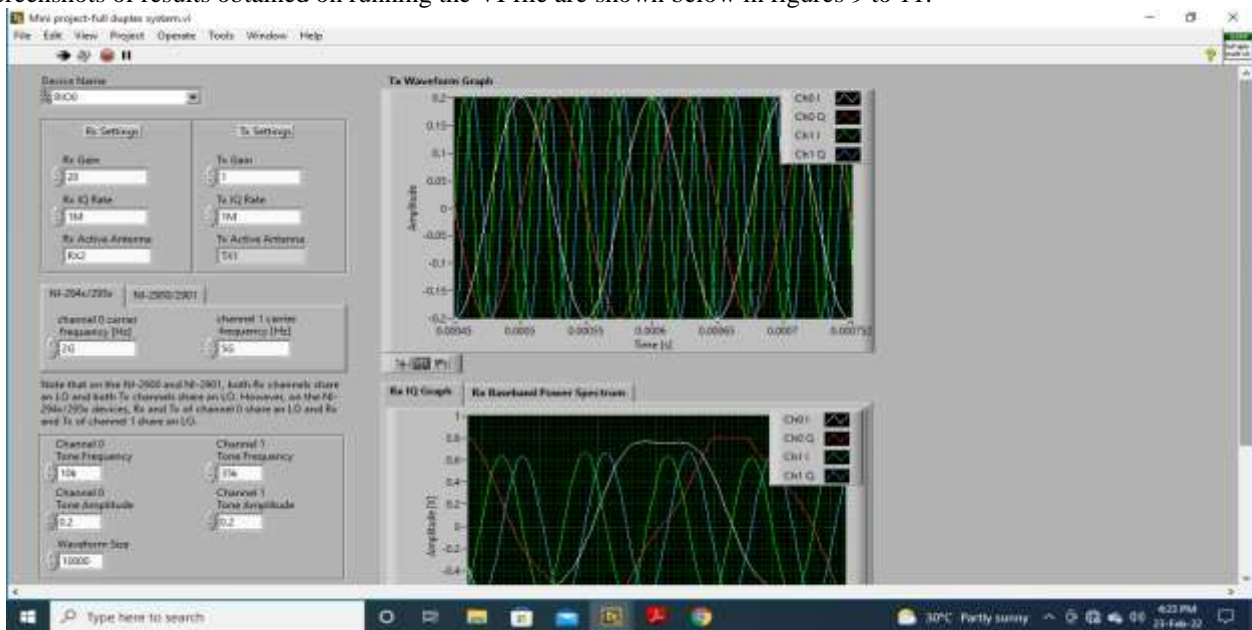

Fig 9 Transmitted waveform

To transmit signal from both channel 0 and channel 1 Tx Gain is 1, Tx IQ rate is 1M, Channel 0 carrier frequency will be 2GHz, Channel 1 carrier frequency will be 5GHz, Channel 0

tone frequency is 10KHz, Channel 1 carrier tone frequency is 35KHz. Channel 0 tone amplitude is 0.2V, Channel 1 tone amplitude is 0.2V and waveform size will be 10000.

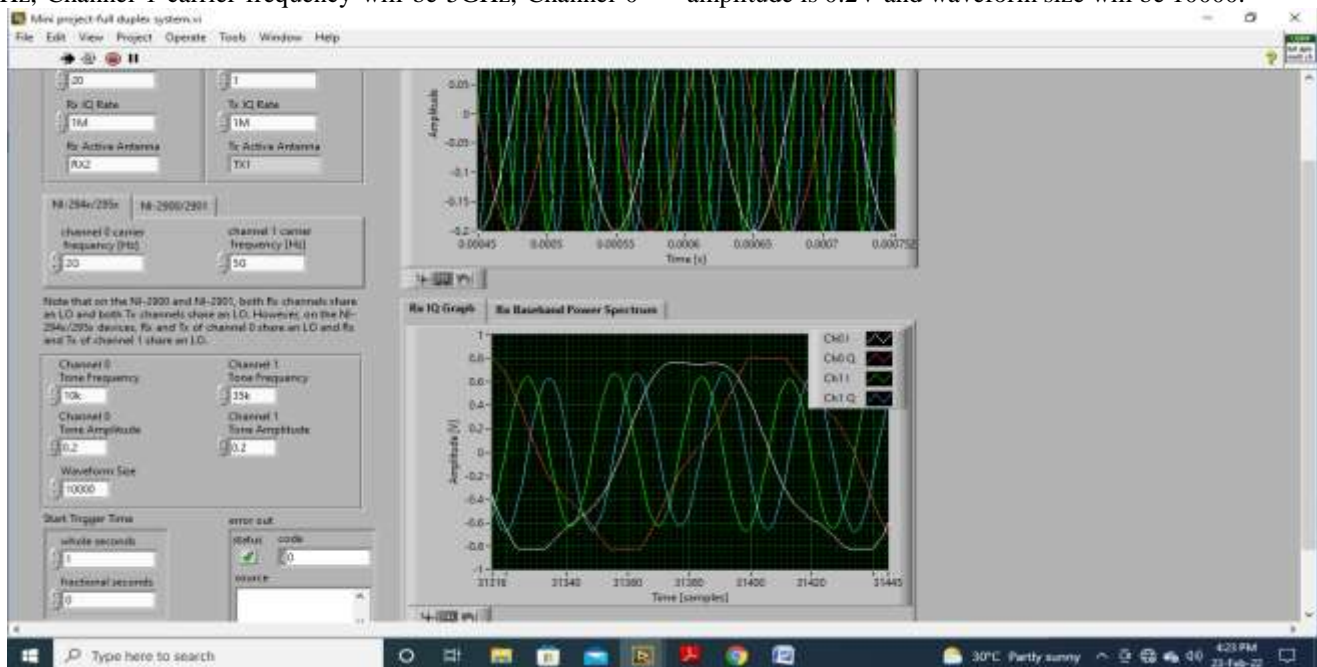

Fig 10 Received waveform in Time domain

To receive the transmitted waveform Rx Gain is set at 20, Rx IQ rate is 1MHz. Rx active antenna is RX2. The transmitted signal is reliably received by the receiver and displayed in both time and frequency domains. But the received signal will

have some changes compared transmitted signal due to presence of noise. In Fig 10 received waveform is shown in time domain. Fig 11 shows the received signal displayed as baseband power spectrum.

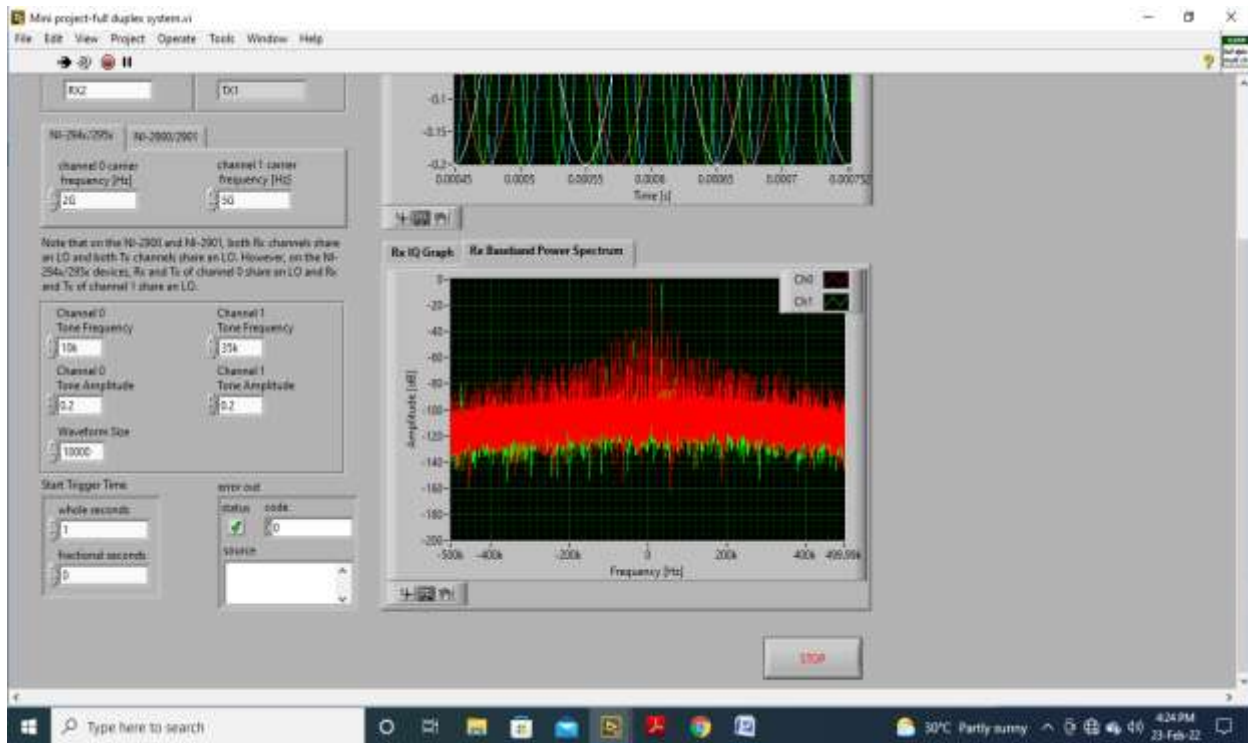

Fig 11 Received signal in frequency domain

VI. CONCLUSION

A Full Duplex Wireless Communication System was prototyped using NI USRP and LabVIEW 2021 Software. This implementation provides a real time scenario and helps in analysis and performance evaluation. Prototyping using NI USRP provides many advantages, but the main limitation is line of sight communication. It is found that when both the transmitter and receiver are within line-of-sight with each other, only then the desired output is obtained. During NLoS conditions, the performance falls. But it can be seen that efficient transceiver of information is achieved with this full duplex system.

VII. REFERENCES

- [1] T. Chen, J. Zhou, M. B. Dastjerdi, J. Diakonikolas, H. Krishnaswamy and G. Zussman, (2017), "Demo abstract: Full-duplex with a compact frequency domain equalization-based RF canceller," 2017 IEEE Conference on Computer Communications Workshops (INFOCOM WKSHPs), Atlanta, GA, USA, 2017, pp. 972-973, doi: 10.1109/INFOCOMW.2017.8116516.
- [2] T. Chen, J. Zhou, Nicole Grimwood, Rel Fogel, (2016), "Full-Duplex Wireless based on a Small-Form-Factor Analog Self-Interference Canceller", *MobiHoc '16: Proceedings of the 17th ACM International Symposium on Mobile Ad Hoc Networking and Computing* July 2016 Pages 357–358 <https://doi.org/10.1145/2942358.2942397>
- [3] M. E. Knox, (2012), "Single antenna full duplex communications using a common carrier," *WAMICON 2012 IEEE Wireless & Microwave Technology Conference*, Cocoa Beach, FL, USA, 2012, pp. 1-6, doi: 10.1109/WAMICON.2012.6208455.
- [4] F. B. Serkin and N. A. Vazhenin, (2013), "USRP platform for communication systems research," 2013 15th International Conference on Transparent Optical Networks (ICTON), Cartagena, Spain, 2013, pp. 1-4, doi: 10.1109/ICTON.2013.6602738.
- [5] Elliott C, Vijayakumar V, Zink W, Hansen R.(2007), *National Instruments LabVIEW: A Programming Environment for Laboratory Automation and Measurement*. JALA: Journal of the Association for Laboratory Automation. 2007;12(1):17-24. doi:10.1016/j.jala.2006.07.012
- [6] C. Despina-Stoian et al., (2021), "USRP Experimental Approach for Digital Self-Interference Cancellation in Full-Duplex Communications," 2021 International Conference on Advanced Technologies for Communications (ATC), Ho Chi Minh City, Vietnam, 2021, pp. 232-236, doi: 10.1109/ATC52653.2021.9598203.
- [7] Antonio Costanzo, Valeria Loscri, (2021), Full duplex Visible Light Communication Platform based on GNU Radio and USRP 2920. *European GNU Radio Days*, Jun 2021, Poitiers, France. fahal-03233986f
- [8] Armas Jiménez, Sergio et al. (2021), "Self Interference Cancellation on a Full Duplex DFTs-OFDM System



- using GNU Radio and USRP.” IEEE Latin America Transactions 19 (2021): 1781-1789.
- [9] NI USRP-294x/293x Datasheet. <http://www.ni.com/datasheet/pdf/en/ds-355>.
- [10] D. Bharadia, E. McMillin, and S. Katti.(2013), Full duplex radios. In Proc. ACM SIGCOMM'13, 2013.
- [11] El Khattabi, Mohammed, Khaldoun, Mohammed, Elmesbahi, Jelloul and Errami, Ahmed. (2021), "In-Band Full-Duplex FSK transceiver for IoT" Frequenz, vol. 75, no. 9-10, 2021, pp. 419-429. <https://doi.org/10.1515/freq-2020-0208>.
- [12] Y. Liao, L. Song, Z. Han, and Y. Li, (2015), “Full duplex cognitive radio: a new design paradigm for enhancing spectrum usage,” Communications Magazine, IEEE, vol. 53, no. 5, pp. 138–145, May 2015.

IJEAST

INTERNATIONAL JOURNAL
OF ENGINEERING APPLIED SCIENCE
AND TECHNOLOGY

ABOUT IJEAST

International Journal of Engineering Applied Science and Technology (IJEAST) is a peer-reviewed, open access journal that publishes high-quality research papers in the field of Engineering, Applied Science and Technology.

IJEAST aims to provide a platform for researchers, academicians, and professionals to share their innovative ideas, research findings, and practical experiences with the global scientific community.

FOCUS AREAS

- Engineering
- Applied Science
- Technology
- Innovation & Development
- Interdisciplinary Studies



PEER REVIEWED

All submissions are rigorously peer reviewed to ensure quality.



OPEN ACCESS

Free and unrestricted access to research for all.



GLOBAL REACH

Connecting researchers and professionals worldwide.



TIMELY PUBLICATION

We ensure a swift and efficient publication process.



For more information, visit our website

www.ijeast.com



INTERNATIONAL JOURNAL
OF ENGINEERING APPLIED SCIENCE
AND TECHNOLOGY

✉ editor@ijeast.com

🌐 www.ijeast.com

📍 India



2455-2143