



IJEAST

INTERNATIONAL JOURNAL
OF ENGINEERING APPLIED SCIENCE
AND TECHNOLOGY



VOLUME : 5 ISSUE : 4 Print / Issue Publication Date: 15-Oct-2020



ISSN : 2455-2143



DOI : 10.33564/IJEAST.2020.v05i04.026

Indexed In



WWW.IJEAST.COM

editor@ijeast.com

AN IMAGE TRANSFER USING NI-USRP

Bharathi R
Assistant Professor
Department of ECE
GSSSIETW, Mysuru

Megha T R
Student
Department of ECE
GSSSIETW, Mysuru

Abstract: The National instruments (NI) Universal Software Radio Peripheral (USRP) are RF transceivers used for the advancement and study of software –defined Radio (SDR). The NI-USRP transceivers can transmit and receive the radio-frequency signals in several bands and are used in the area of communication, education and research. In this paper we are trying to transfer an image using NI-USRP using LabVIEW.

Keywords— NI-USRP, Lab VIEW, SDR

I. INTRODUCTION

Communication is an act of carrying information from source to destination. Modulation is the process of varying one or more properties of carrier signals with respect to modulating signal. The two extensively used modulation techniques are

1. Analog modulation
2. Digital modulation.

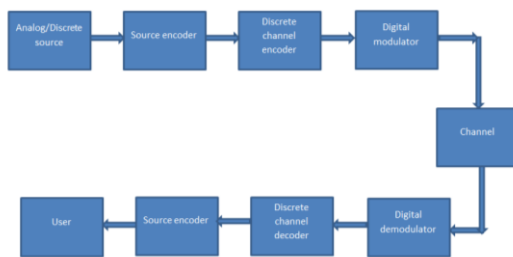

Fig 1: Digital Modulation System

Digital Modulation supports high information capacity, involves achieving security, faster & great efficiency of quality communication. Hence, digital modulation techniques have a greater demand, for their capacity to convey larger amounts of data than analog modulation techniques. The three digital modulation schemes available are [9]

1. Amplitude Shift Keying (ASK)
2. Frequency Shift Keying (FSK)
3. Phase Shift Keying (PSK)

Amplitude shift keying (ASK): ASK is a form of amplitude modulation that represents digital data as variations in the amplitude of a carrier wave. In an ASK system, the binary

data symbol 1 is represented by transmitting fixed amplitude carrier wave and symbol 0 by zero amplitude.

Advantages: 1. The main advantage of ASK modulation is generation of ASK is very much easy. 2. It offers higher bandwidth efficiency. 3. It has simple receiver design. 4. Both ASK modulation and demodulation processes are relatively inexpensive. 5. These days ASK modulation schemes are used to transfer digital signals through optical fibers

Advantage of QAM is that, makes efficient use of bandwidth

Applications: 1. ASK modulation is used almost in every digital communication link including cell phone and cable TV. 2. It is used at radio frequencies to transmit Morse code.

Software Defined Radio (SDR) refers to the process of creating software that performs radio functionality that normally would be implemented in hardware. [3] SDR is a communication platform that uses software for implementing digital communications algorithms. Universal Software Radio Peripheral (USRP) as the SDR to exhibit the practical challenges of wireless communications. The USRP consists of a Programmable Field Gate Array (FPGA), Analog to Digital Converters (ADC), Digital to Analog Converters (DAC), and a Universal Serial Bus controller (USB). It is designed to interface an analog signal generated by, or transferred to, software National Instrument-Universal software radio peripheral (NI-USRP) devices are software- defined Radios (SDP) used for RF applications. NI USRP transceiver can transmit and receive RF signals in several bands. Since LabVIEW is a graphical programming language, NI-USRP provides the easiest way in prototyping communication research.

II. METHODOLOGY

Let us consider an image as an input signal given to the modulation block. Modulation varies the properties of the carrier signal in accordance with the image signal. The up-converter converts the band of frequencies from lower frequencies to a higher frequency. Transmitting antenna converts electrical currents into its equivalent electromagnetic radiations signals.[14]

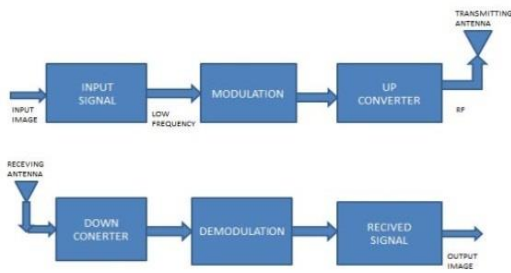

Fig 2: Block diagram of transmission & reception of image



Fig 3: NI-USRP

Following common software-defined radio architecture, NI USRP hardware consists of high-speed analog to digital converters (ADCs) and digital to analog converters (DACs) it also features a fixed FPGA for the digital down conversion (DDC) and digital up conversion (DUC) steps.

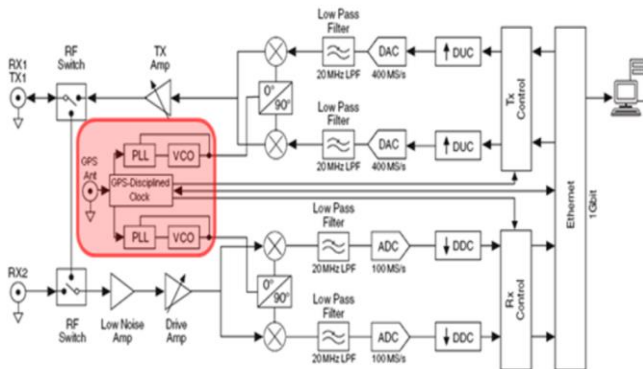

Fig 4: Block diagram of NI USRP module

The internal block diagram of NI-USRP module is shown in figure 4. The NI-USRP is able to receive the signal when the received signal is mixed from RF using a direct conversion receiver baseband I/Q components. The digitized I/Q data follow parallel paths through a digital down-conversion process that mixes, filters, and decimates the input signal to a user -specified rate.[4] The down converted samples are then

passed to the host computer through a standard gigabit Ethernet cable.

During transmission, the baseband I/Q signal samples are processed by the host computer and passed to the USRP at a given sample rate through the Ethernet cable. The USRP hardware receives the incoming signal and processes it to a higher sampling rate using a digital up conversion (DUC) process and then converts the signal to analog with the digital to analog converter (DAC). The resulting analog signal is then involved in the required carrier frequency.

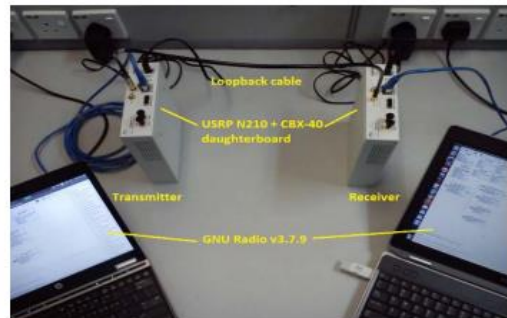

Figure 5: SDR setup

In this paper, the process of ASK modulation using LABVIEW and NI-USRP on the SRD platform is shown. The USRP-2901 consists of RF transceiver with full-duplex, Multiple Input Multiple Output operation. It offers bus-power connectivity with USB 3.0 or USB 2.0. Fig. 3 shows the USRP-2901, it consists of 2 channels & the frequency range is 70 MHz to 6 GHz. In this image signal are transmitted from a

transmitter USRP and received by the destination USRP. The SDR setup for the same is shown in Figure 5, USRP 2901 is used & also transmitter, receiver & loop cables are used.

In the proposed method, the ASK modulation scheme was first used to transfer images but to achieve a better quality of image QAM modulation scheme was used.

QAM Modulator

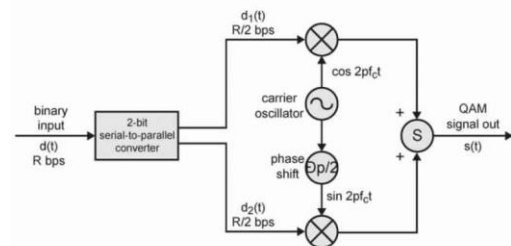

Fig 6: Block diagram of QAM

QAM is a digital modulation technique, which combines two amplitude modulated (AM) signals into a single channel. The reason for choosing QAM as the modulation was, it offers advantages for the transmission of image, best utilization of the bandwidth. 16 QAM was used for the proposed method.

III. RESULT

Tests have been conducted for both ASK & QAM modulation. Figure 7 shows the block diagram of ASK modulation scheme

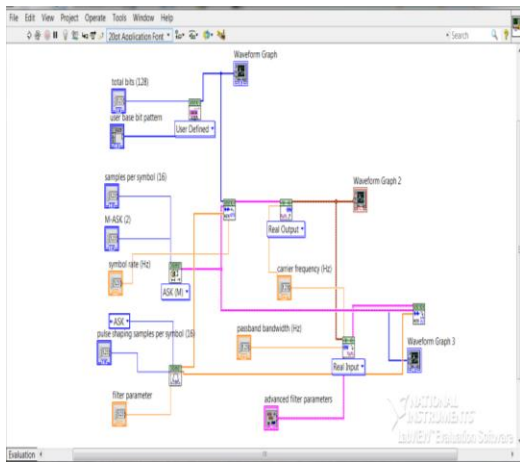

Fig 7: Circuit diagram of ASK in block diagram panel

Figure 8 shows the waveforms of the ASK

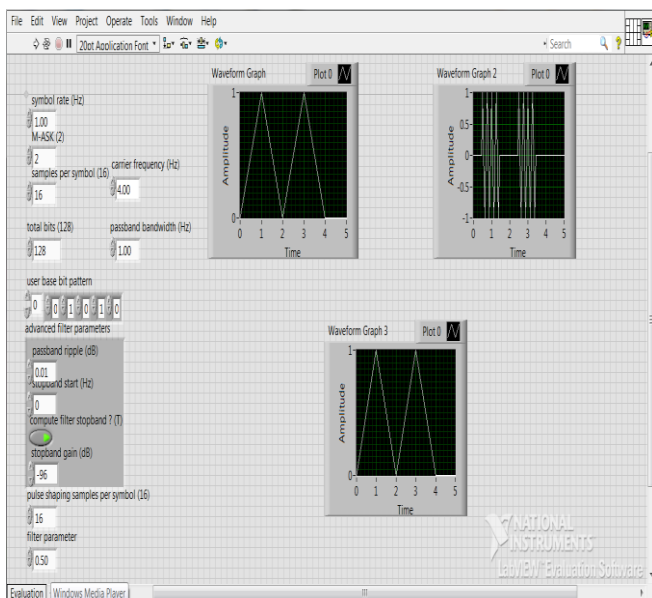

Fig 8: output waveform of ASK in front panel

Figure 9 shows block diagram of QAM modulation scheme

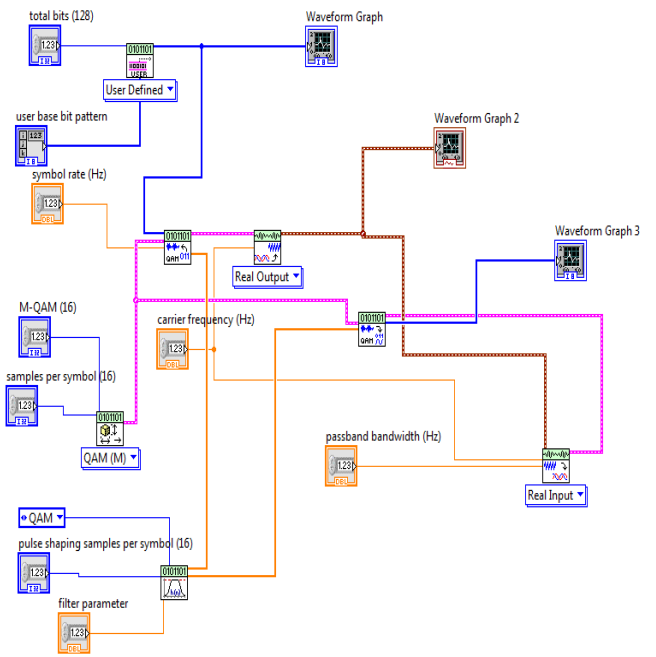

Fig 9: Circuit diagram of QAM in block diagram panel

Figure 10 show the wave forms of QAM modulation scheme

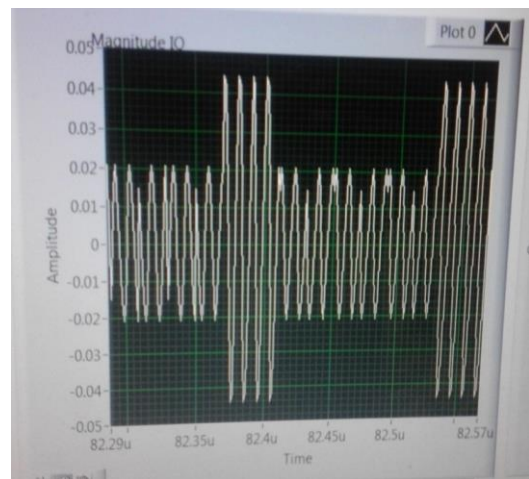

Fig 10: output waveform of QAM in front panel

Figure 11 show the output waveform of 16-QAM Constellation.

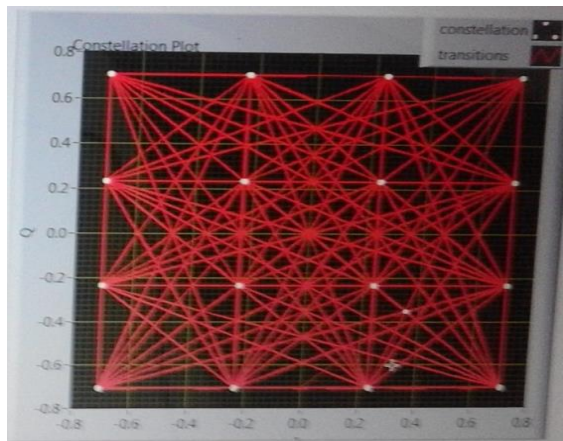

Fig 11: Output Waveform of 16-QAM Constellation

Figure 12 shows the screen of QAM image transmitter using NI-USRP in LabVIEW

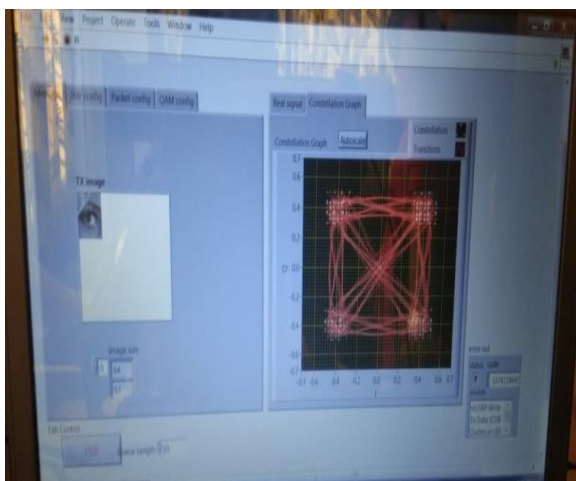

Fig 12: Result of QAM Image Transmitter

The below figure shows the result of QAM image receiver using NI-USRP in LabVIEW.

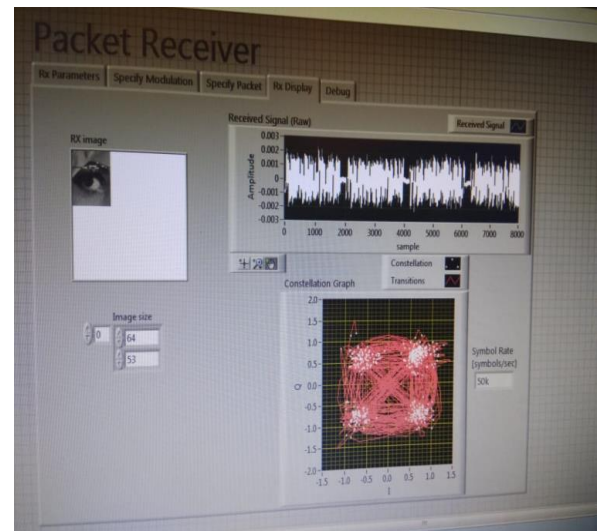

Fig 13: Result of QAM Image Receiver

IV. CONCLUSION

QAM is one of the important modulation scheme because of its own advantages in current technologies. Also, this scheme can be implemented in LabVIEW with the use of the NI Modulation Toolkit. This toolkit, in conjunction with the vector signal generator and vector signal analyzer, implements QAM for signals in the real world.

In this paper, we have tried to send and receive a gray scale small image using QAM modulation through NI-USRP in LabVIEW. The image size is 62*53, which is very small image. If we try to send large image ram memory was full and causes an error. So the future scope of the paper is using image compression algorithm on image for reducing image size & then try to transmit using NI- USRP.

V. REFERENCE

- [1] A. A. Efros and W. T. Freeman (2001) , “Image quilting for texture synthesis and transfer”, in ACM SIGGRAPH.
- [2] E. Blossom (Nov 2004) , “Exploring GNU Radio”.
- [3] M. Ettus(2008), “How to Get Ready for the USRP2”.
- [4] “ADROIT: GNU Radio Architectural Changes,” May 2007, available at http://acert.ir.bbn.com/downloads/adroit/gnuradio_architectural-enhancements-3.pdf.
- [5] “MBLOCK, Inband USRP2 Future?” June 2008, available at <http://www.nabble.com/mblock,inband,-usrp2-Future—td18152536.html>.
- [6] E. Kohler, R. Morris, et.al (Aug 2000) “The Click Modular Router,” ACM Trans. on Computer Systems, vol. 18, no. 3 (pp. 263–297) Aug 2000.



- [7] S. Alamouti (Oct 1998), “A Simple Transmitter Diversity Scheme for Wireless Communications,” IEEE JSAC, vol. 16(pp. 1451 – 1458).
- [8] A. Khalifeh and H. Yousefi’zadeh (2008), “An Optimal UEP Scheme of Audio Transmission over MIMO Wireless Links,” in Proc. IEEE WCNC, Mar. 2008.
- [9] L. Xu, K. Harfoush, and I. Rhee(2004), “Binary Increase Congestion Control (BIC) for Fast Long-Distance Networks,” in Proc. IEEE INFOCOM, 2004.
- [10] J. Mahdavi, “Enabling High Performance Data Transfers on Hosts”, technical note, Pittsburgh Supercomputing Center, Dec. 1997, available at <http://www.psc.edu/networking/perftune.html>.
- [11] “TCP Tuning Guide,” Nov. 2005, distributed Systems Department, Available at <http://dsd.lbl.gov/TCP-tuning/TCP-tuning.html>.
- [12] K. Mandke, S. Choi, G. et.al , “Early Results on Hydra: A Flexible MAC/PHY Multihop Testbed,” in Proc. IEEE VTC, Dublin, Ireland, Apr. 2007.
- [13] R. Dhar, G. George, A. Malani, and P. Steenkiste, “Supporting Integrated MAC and PHY
- [14] “Software Development for the USRP SDR”, in Proc. IEEE Workshop on Networking Technologies for software Defined Radio Networks, Sept. 2006
- [15] T. Schmid, O. Sekkat, and M. B. Srivastava “An Experimental study of network performance Impact of Increased latency in software defined radios “ in Proc. International Conference on Mobile Computing

IJEAST

INTERNATIONAL JOURNAL
OF ENGINEERING APPLIED SCIENCE
AND TECHNOLOGY

ABOUT IJEAST

International Journal of Engineering Applied Science and Technology (IJEAST) is a peer-reviewed, open access journal that publishes high-quality research papers in the field of Engineering, Applied Science and Technology.

IJEAST aims to provide a platform for researchers, academicians, and professionals to share their innovative ideas, research findings, and practical experiences with the global scientific community.

FOCUS AREAS

- Engineering
- Applied Science
- Technology
- Innovation & Development
- Interdisciplinary Studies



PEER REVIEWED

All submissions are rigorously peer reviewed to ensure quality.



OPEN ACCESS

Free and unrestricted access to research for all.



GLOBAL REACH

Connecting researchers and professionals worldwide.



TIMELY PUBLICATION

We ensure a swift and efficient publication process.



For more information, visit our website

www.ijeast.com



INTERNATIONAL JOURNAL
OF ENGINEERING APPLIED SCIENCE
AND TECHNOLOGY

✉ editor@ijeast.com

🌐 www.ijeast.com

📍 India



2455-2143