



IJEAST

INTERNATIONAL JOURNAL
OF ENGINEERING APPLIED SCIENCE
AND TECHNOLOGY



VOLUME : 7 ISSUE : 02 Print / Issue Publication Date: 05-Aug-2022



ISSN : 2455-2143



DOI : 10.33564/IJEAST.2022.v07i02.026

Indexed In



WWW.IJEAST.COM

editor@ijeast.com



POWER GENERATION USING WASTE MATERIALS BASED IOT APPROACH

Fatma Fahad Alzadjali

Electronics and Communication Engineering, Middle East College

Abstract— Every developing country relies heavily on electricity. To meet the increased demand for electricity, many types of power plants are being created. The supply-demand imbalance is widening as natural resources are depleted. Power generation from industrial waste is critical for addressing the energy problem. This is one of the other solutions to the problem. This document was created as a solution and approach for generating power from solid waste materials (SWM). It plans to develop electrical energy power from Municipal Solid Waste Materials, transform that low electrical energy into higher electrical energy power, and charge mobile phones with the generated electricity. This article and its findings will be beneficial to the renewable energy industry.

I. INTRODUCTION

An electrical charge is produced by a group of electrons moving from one atom to another [1]. The flow of electricity measured in amperes is known as current (I). Voltage is the amount of power available to drive electricity along a circuit, and it is measured in volts (V) [2][3]. Waste is a substance of human civilization; it can take the shape of a liquid or a solid, and its components are hazardous to human health. The following are the reasons why we need to use garbage to generate power in Oman: The first reason is that Oman has a large amount of useless garbage. The second argument is that the government saves money by paying less for power. The significance of this project is to create electrical energy power from Municipal Solid Waste Materials (MSWM) and transform that lower electrical energy power into higher electrical energy power [4].

II. LITERATURE

A. Electricity generation – industrial waste management. Any developing country must have access to electricity. To meet the rising demand for electricity, many types of power plants are being built. The gap between supply and demand continues to increase as natural resources are depleted. Electricity generation from industrial waste is important to addressing the energy problem [5-8]. This is one of the alternative approaches to dealing with the circumstance. This study presents the utilization of waste gases produced during the production process in major organizations and factories as a novel method of energy generation. In the proposed technology, small turbines revolve by channeling high-

pressure waste gas from exhausts to create energy. It is regarded as a highly efficient means of generating power. Because businesses and factories demand a consistent and large amount of power supply, there is a huge disparity in electrical energy output and consumption [9-15]. As a result, increased power generation is important. Because generated power is disseminated to many different sectors of society and natural resources are dwindling, a new method of generating electricity should be developed to bridge the supply and demand gap. This work develops and addresses a method for producing electrical energy from waste resources, such as waste gas emitted from manufacturing outlets. The pressure of the gases is adjusted to satisfy the fundamental requirements of the enterprises, which regulates the generation of energy. Waste heat conversion into electricity [16-20].

High and rising energy and fossil fuel prices, as well as the desire to reduce CO₂ emissions, are powerful drivers of technical innovation. Cement and other energy-intensive industries are looking for strategies to reduce their dependency on energy costs [21-24]. One untapped energy potential today is the vast quantity of low and medium-temperature heat wasted in cement plants and processes. We'll show how we employ technologies to convert low-temperature waste heat into electricity [25-30]. In cement plants, recovering as much waste heat as feasible and maximizing waste heat conversion leads to considerable efficiency increases. ORC power plants have long been used to generate energy from low-temperature waste heat sources [31-32]. Investments in this sector are becoming more tempting owing to the environmental and economic benefits. ORC power plants increase cement plant electrical energy efficiency by up to 20%, dramatically reduce indirect CO₂ emissions, and conserve water. Installing an ORC power plant in a high-efficiency cement factory (waste gas temperature after pre-heater generally between 250 and 300°C) improves energy efficiency and reduces CO₂ emissions caused by electricity use. Even under these conditions, power consumption is decreased by around 20%. Lowering power consumption means a CO₂ emission reduction of roughly 10,000 t per year, depending on the country of installation.

B. Converting food waste to usable energy in the urban environment through anaerobic digestion

Urban sustainability has emerged as a major concern in North America, notably in Canada. As our cities continue to grow, consuming large quantities of energy and creating massive

amounts of rubbish, we must figure out how to deal with this issue properly and sustainably [33-41]. For cities, anaerobic digestion is a feasible waste-to-energy process. Even though anaerobic digestion (AD) has been a mature and viable energy source for over 100 years and is utilized in numerous countries throughout the world to generate electricity and heat in rural settings, it has yet to make a significant migration to the urban environment. Anaerobic digestion, when applied to organic waste generated in metropolitan areas, might provide a crucial solution to growing trash worries while simultaneously cutting external energy requirements. As landfills in Canada and throughout the world reach capacity, a carbon-neutral technology that may generate power and heat locally while lowering volatile solids by up to 50% should be further researched. As fuel prices rise, the cost of transporting garbage outside of cities to landfills will grow more. In the urban setting, large amounts of this rubbish might be kept, digested, reduced, and converted into useable energy, providing useful electricity. The feasibility of urban anaerobic digestion is studied in this book, which includes a case study from Concordia University's downtown campus in Montreal.

C. Clean Electrical Power Generation from Municipal Solid Waste

The everyday creation of mountains of municipal solid waste (MSW) by humanity is a global issue. From the standpoints of environmental responsibility and economic viability, burning MSW in a modern waste to energy (WTE) plant at approximately 1150 °C to generate heat used to create steam that produces electricity, distills potable (drinking) water, and hot water for industrial uses is an efficient solution for dealing with MSW disposal [33-41]. Every day, a new plant module burns 180 metric tons of MSW, producing at least 144 megawatt hours of power and 912,000 liters of potable water. Waste Heat to Energy (WHE) systems generate extra electricity by using waste heat from saturated steam exiting the primary steam turbine and waste heat recovered from wet scrubbing of furnace flue gases.

III. BLOCK DIAGRAM

This block diagram explains transforming waste to power through heating. Set fire to the waste. The sensor will detect and display the warmth, while the LED bulb will display the heating by creating it. The battery does not have any stored energy; it will store the electricity generated by heating. In this block diagram, Arduino is the important process. The boosting coil is a technique that transforms low voltage to high voltage and high power, which is displayed on the LCD and charges the phone.

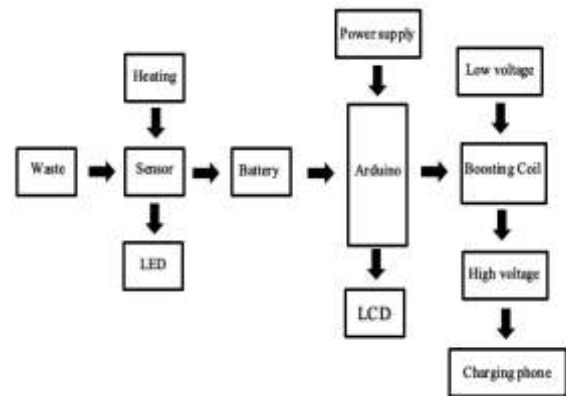

Fig. 1. Block Diagram

IV. FLOW CHART

The process of turning SWM to electricity is depicted in this flowchart. Turn on the lighter and heat the SWM (plastic and paper); the LED will light up to signal that it is heating. The battery will store heat-generated power. This energy will be PL. As a result, the PL will be converted to PH using BC. The next step will be to see if it generates electricity between 5 and 15 watts. The LCD will show the amount of electricity received from BC to charge the phone.



V. CIRCUIT DIAGRAM

SWM is converted to electricity in this circuit schematic. The LM35 has three pins (VCC, OUT, and GND), with VCC linked to the LCD's VDD, analog out connected to Arduino UNO pin A0, and the third pin attached to ground. The boosting coil is linked to Arduino pin 13 and the LED has the +ve connected to 5V and the -ve attached to GND. The LCD is likewise powered by 5V.

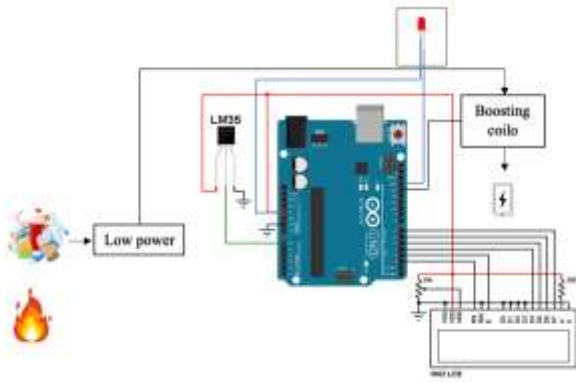

VI. CONCLUSION

To summarize this project planning report, it is observed that there is a large amount of solid waste material (SWM) that was burnt without being used in any way, and ways of creating electrical energy after years require alternative means of production. This effort solved the problem and contributed to the development of another method of generating electricity. It intends to create electrical energy power from Municipal Solid Waste Materials, transform that low electrical energy into higher electrical energy power, and charge mobile phones with the generated electricity. Given the tremendous improvements and growth in the field of Ai/machine Learning Technologies [41-46] and its reach in the field of predictive technologies, this is the most outstanding solution for the forecasting applications required.

This article and its production will be beneficial in terms of renewable energy and a secondary source of electrical energy. We specified the relationships, input parameters, data collection, and processing in the preceding sections. The approach and timeframe for the project have also been determined. Because the data has not yet been received, the design and testing strategies outlined in the preceding section may need to be modified to better suit the data and produce the best possible outcomes. The full scope and implementation of the model will be revealed in the project's next phase. Finally, I would like to acknowledge MEC for providing all kinds of facilities in completing my research.

VII. REFERENCE

- [1] S. R. R. D. Purusothaman, R. Rajesh, K. K. Bajaj and V. Vijayaraghavan, "Implementation of Arduino-based multi-agent system for rural Indian microgrids," in 2013 IEEE Innovative Smart Grid Technologies-Asia (ISGT Asia), Bangalore, India, 10-13 Nov. 2013.
- [2] Battery. energy education. (2022). Retrieved 26 May 2022, from <https://energyeducation.ca/encyclopedia/Battery>.
- [3] Hussain, S.M., Yusof, K.M., Hussain, S.A., Khan, A.B. (2022). An Efficient Interface Selection Scheme (DSRC/LTE) of Vehicles for Data Dissemination
- [4] Enabling V2V Communication to Support Internet of Vehicles (IoV). In: Reddy, V.S., Prasad, V.K., Wang, J., Reddy, K.T.V. (eds) Soft Computing and Signal Processing. Advances in Intelligent Systems and Computing, vol 1340. Springer, Singapore. https://doi.org/10.1007/978-981-16-1249-7_54
- [5] Börrnert, T., & Bürki, T. (2010, March 1). Waste heat conversion into electricity. IEEE Xplore. <https://doi.org/10.1109/CITCON.2010.5469769>
- [5] Hakimi, A., Yusof, K. M., Azizan, M. A., Azman, M. A. A., & Hussain, S. M. (2021). A Survey on Internet of Vehicle (IoV): A plications & Comparison of VANETs, IoV and SDN-IoV. ELEKTRIKA-Journal of Electrical Engineering, 20(3), 26-31.
- [6] Curry, N., & Pillay, P. (2009, October 1). Converting food waste to usable energy in the urban environment through anaerobic digestion. IEEE Xplore. <https://doi.org/10.1109/EPEC.2009.5420983>
- [7] K. M. Y. Shaik Mazhar Hussain, "Dynamic Q-learning and Fuzzy CNN Based Vertical Handover Decision for Integration of DSRC, mmWave 5G and LTE in Internet of Vehicles (IoV).," J. Commun., vol. 16, no. 5, pp. 155-166, 2021/5.
- [8] How does a boost converter work? | Toshiba Electronic Devices & Storage Corporation | Asia-English. Toshiba.semicon-storage.com. (2022). Retrieved 26 May 2022, from <https://toshiba.semicon-storage.com/ap-en/semiconductor/knowledge/faq/linear/how-does-a-boost-converter-work.html>.
- [9] S. M. H. Afaq Ahmad, "Handover Latency and Interoperability in Future Generation Wireless Mobile Heterogeneous Environment," Oriental Journal of Computer Science and Technology, vol. 12, no. 3, 2020.
- [10] How to check a faulty temperature sensor? - Peak Sensors. Peak Sensors. (2022). Retrieved 26 May 2022, from <https://peaksensors.co.uk/blog/check-a-faulty-temperature-sensor/>.
- [11] K. M. Y. S. A. H. R. A. Shaik Mazhar Hussain, "Performance evaluation of vertical handover in Internet of Vehicles," International Journal on Smart Sensing and Intelligent Systems, vol. 14, no. 1, pp. 1-16, 2021/6/28.
- [12] In-Depth: Interfacing LM35 Temperature Sensor with Arduino. Last Minute Engineers. (2022). Retrieved 26 May 2022, from <https://lastminuteengineers.com/lm35-temperature-sensor-arduino-tutorial/>.
- [13] S. M. H. A. F. Hassan Mohammed Obaid Al Marzuqi, "Device activation based on voice recognition using Mel frequency cepstral coefficients (MFCC's) algorithm," Int. Res. J. Eng. Technol, vol. 6, no. 3, pp. 4297-4301, 2019.
- [14] Al Hattali, Sultan Saleem Khalaf, Shaik Mazhar Hussain, and Anilloy Frank. "Design and development



- for detection and prevention of ATM skimming frauds." Indonesian Journal of Electrical Engineering and Computer Science 17.3 (2020): 1224-1231.
- [15] Joseph, J. (2022). Everything you need to know about the Arduino Hardware. Circuitdigest.com. Retrieved 26 May 2022, from <https://circuitdigest.com/article/everything-you-need-to-know-about-arduino-uno-board-hardware>.
- [16] I. Z. A. B. K. Shaik Mazhar Hussain, "Interoperability in Future Generation Wireless Communication Systems-A Review," Solid State Technology, vol. 63, no. 1s, pp. 1250-1257, 2020/1/31.
- [18] Nakkasem, T. (2022). V-Model. Medium. Retrieved 26 May 2022, from <https://medium.com/software-engineering-kmitl/v-model-3a71622b3d82>.
- [19] Hussain, Shaik Mazhar, Sami Abdullah Saud Ambu Saidi, and Anilloy Frank. "IOT based Monitoring and Detection of Electromagnetic (EM) Radiation Levels." Journal of Student Research (2019).
- [20] Reddy, P. R., & Teja, M. K. R. (2010, May 1). Electricity generation — Industrial waste management. IEEE Xplore. <https://doi.org/10.1109/EIT.2010.5612111>
- [21] S. M. H. A. F. Ammar Yasir Hamood Al Rawahi, "Design and Development of IOT based Low Power Consumption in Employee Meeting Rooms," Journal of Student Research, 2019.
- [22] Sensor Basics LM35 Temperature Sensor. Dnatechindia.com. (2022). Retrieved 26 May 2022, from <https://www.dnatechindia.com/LM35-Temperature-Sensor-Basics.html>.
- [23] K. M. Y. S. A. H. P. E. N. Shaik Mazhar Hussain, "A review of interoperability issues in Internet of vehicles (ioV)," International Journal of Computing and Digital Systems, vol. 8, no. 1, pp. 73-83, 2019/1/1.
- [24] Software start up and test of Arduino Uno. NAROM. (2022). Retrieved 26 May 2022, from <https://www.narom.no/undervisningsressurser/the-cansat-book/the-primary-mission/software-start-up-and-test-of-arduino-uno/>.
- [25] S. J. B. Shaik Mazhar Hussain, "Design of women safety system using RFID,8051microcontroller and GSM based technology a prototype," International Journal of Advanced Research in Computer and Communication Engineering, vol. 3, no. 6, p. 2, 2014.
- [26] Varadi, A. Sz., Strand, L., & Takacs, J. (2007, May 1). Clean Electrical Power Generation from Municipal Solid Waste. IEEE Xplore. <https://doi.org/10.1109/ICCEP.2007.384227>
- [27] Shaik, Jhani Bhasha, and Mazhar Hussain Shaik. "Voter Identification and Detection System using RFID and GSM to stop rigging in the elections." International Journal of Innovative Research in Electrical, Electronics, Instrumentation and Control Engineering 2.6 (2014).
- [28] waste disposal | Types & Methods. Encyclopedia Britannica. (2022). Retrieved 28 March 2022, from <https://www.britannica.com/technology/waste-disposal-system>.
- [29] K. M. Y. S. A. H. Shaik Mazhar Hussain, "A conceptual framework on IOT based system desginto prevent road accidentsin accident prone cities," in 2017 International Conference on Infocom Technologies and Unmanned Systems (Trends and Future Directions) (ICTUS), Dubai, 2017.
- [30] K. M. Y. S. A. H. Shaik Mazhar Hussain, "Interoperability Issues in Internet of vehicles- A Survey," in 2018 3rd International Conference on Contemporary Computing and Informatics (IC3I), India, 2018.
- [31] waste to energy. SIEMENS ENERGY. (2022). Retrieved 26 May 2022, from <https://www.siemens-energy.com/global/en/offerings/power-generation/gas-engines/aplication/waste-to-energy.html>.
- [32] K. M. Y. S. A. H. Shaik Mazhar Hussain, "Interoperability in Connected Vehicles – A Review," I.J. Wireless and Microwave Technologies, vol. 1, no. 11, p. 11, 2018.
- [33] What Is Electricity? - Definition & Concept. study.com. (2022). Retrieved 28 March 2022, from <https://study.com/academy/lesson/what-is-electricity-definition-lesson-quiz.html>.
- [35] M. V. T. Suprita M. Patil, "IoT based solar energy monitoring system," in 2017 International Conference on Energy, Communication, Data Analytics and Soft Computing (ICECDS), Chennai, India, 2017.
- [36] E. Kabalci, A. Gorgun and Y. Kabalci, " 4th International Conference on Power Engineering, Energy and Electrical Drives," in 4th International Conference on Power Engineering, Energy and Electrical Drives, Istanbul, Turkey, 13-17 May 2013.
- [37] L. Wang and K.-H. Liu, "Implementation of a web-based real-time monitoring and control system for a hybrid wind-PV-battery renewable energy system," in 2007 International Conference on Intelligent Systems Applications to Power Systems, Kaohsiung, Taiwan, 5-8 Nov. 2007.
- [38] What Is a Power Supply, a. (2022). What Is a Power Supply & How Does It Work? | Advanced Conversion Technology. Advanced Conversion Technology. Retrieved 26 May 2022, from <https://www.actpower.com/educational/what-is-a-power-supply-and-how-does-it-work/>.
- [39] S. M. Hussain, K. Mohamad Yusof, S. Ashfaq Hussain, R. Asuncion, and S. Ghouse, "Integration of 4G LTE and DSRC (IEEE 802.11p) for Enhancing Vehicular Network Performance in IoV Using Optimal Cluster-Based Data Forwarding (OCDF) Protocol", Int. J. Interact. Mob. Technol., vol. 15, no. 14, pp. pp. 111–124, Jul. 2021.



- [40] Hussain, S.M., Yusof, K.M., Hussain, S.A., & Asuncion, R. (2021). Performance evaluation of vertical handover in Internet of Vehicles. *International Journal on Smart Sensing and Intelligent Systems*, 14, 1 - 16.
- [41] What is LED? - Definition, Working, Properties, Uses, Advantages. BYJUS. (2022). Retrieved 26 May 2022, from <https://byjus.com/physics/light-emitting-diode/>.
- [42] Hussain, S., Yusof, K., Asuncion, R., & Hussain, S. (2021). Artificial intelligence-based handover decision and network selection in heterogeneous internet of vehicles. *Indonesian Journal of Electrical Engineering And Computer Science*, 22(2), 1124. <https://doi.org/10.11591/ijeecs.v22.i2.pp1124-1134>
- [43] S. M. Hussain and E. A. S. N. . Al Saadi, "Voice enabled Elevator system", *J Stud Res*, Jun. 2022.
- [44] I. Al Balushi and S. M. Hussain, "IoT BASED AIR QUALITY MONITORING AND CONTROLLING IN UNDERGROUND MINES ", *J Stud Res*, Jun. 2022.
- [45] S. M. Hussain and N. S. N. S. . AL HABSI, "Protection of foodstuffs in storage warehouses system", *J Stud Res*, Jun. 2022.
- [46] M. K. . AL-Sakiti and S. M. . Hussain, "IoT based monitoring and tracing of COVID-19 contact persons", *J Stud Res*, Jun. 2022.

IJEAST

INTERNATIONAL JOURNAL
OF ENGINEERING APPLIED SCIENCE
AND TECHNOLOGY

ABOUT IJEAST

International Journal of Engineering Applied Science and Technology (IJEAST) is a peer-reviewed, open access journal that publishes high-quality research papers in the field of Engineering, Applied Science and Technology.

IJEAST aims to provide a platform for researchers, academicians, and professionals to share their innovative ideas, research findings, and practical experiences with the global scientific community.

FOCUS AREAS

- Engineering
- Applied Science
- Technology
- Innovation & Development
- Interdisciplinary Studies



PEER REVIEWED

All submissions are rigorously peer reviewed to ensure quality.



OPEN ACCESS

Free and unrestricted access to research for all.



GLOBAL REACH

Connecting researchers and professionals worldwide.



TIMELY PUBLICATION

We ensure a swift and efficient publication process.



For more information, visit our website

www.ijeast.com



INTERNATIONAL JOURNAL
OF ENGINEERING APPLIED SCIENCE
AND TECHNOLOGY

✉ editor@ijeast.com

🌐 www.ijeast.com

📍 India



2455-2143