



IJEAST

INTERNATIONAL JOURNAL
OF ENGINEERING APPLIED SCIENCE
AND TECHNOLOGY



VOLUME : 6 ISSUE : 11 Print / Issue Publication Date: 11-May-2022



ISSN : 2455-2143



DOI : 10.33564/IJEAST.2022.v06i11.031

Indexed In



WWW.IJEAST.COM

editor@ijeast.com



HARMONIC ANALYSIS OF TRANSFORMER'S MAGNETIC INRUSH AND FAULT CURRENT WITH FFT

Avishek Ganguly
Department of EE
Kolkata, West Bengal, India

Abstract— The distorted voltage or current waveform (not purely sinusoidal) contains harmonics. The frequency of harmonics may be integer multiple or fraction of fundamental frequency. Increase of power electronic loads, faults in power system, switching of induction motors, transformer switching, magnetic saturation of transformers core are several reasons of harmonic pollution.

Keywords— Magnetic inrush, fault current, FFT

I. INTRODUCTION

Immediate effects of harmonics

Resonance and its consequences in the current and voltages.
Worsening of the power factor
Reduction of engine power
High currents by the neutral conductor
Overload of the conductors (skin effect), transformers, motors, generators, capacitors.
Stops unexpectedly of the protection devices.
Malfunction of regulation devices
Increase of noises and vibrations.
Distortions of the voltages and currents.
Disturbances in telephone lines.
Over sizing is needed for some components: conductors, transformers, capacitors.

II. THEORY

Medium- or long-term effects

Reduction of life for motors and transformers.
Premature ageing of insulation.
Increase in cost.
Magnetic inrush and fault current are very serious cause of harmonics.

What is inrush –

These transients occur when an unloaded transformer is switched on to normal voltage on its primary side or when a short circuit occurs on its secondary side. The phenomenon pertaining to the switching on of an unloaded transformer is referred to as **switching-in phenomenon** or **inrush phenomenon**.

Characteristics

Inrush currents in transformer are

1. high magnitude
2. harmonic-rich currents.

Factors Affecting the Magnetizing Inrush Currents

- (a) The point – on – voltage wave at the instant of energization.
- (b) The magnitude and polarity of the remanent flux in the transformer core at the instant of energization.
- (c) The total resistance of the primary winding circuit.
- (d) The power source inductance.
- (e) The inductance of the air core in between the energizing winding and the transformer core.
- (f) The geometry of the transformer core.
- (g) The maximum flux – carrying capability of the core materials.

Some Other Factors

- (i) Residual flux existing before energizing the transformer.
- (ii) Size of the transformer.
- (iii) Size of the power system.
- (iv) Type of the magnetic material of the core.
- (v) The method of energizing the transformers or the energization.

Reduction Of Magnetic Inrush Currents

Use of a two – step switch;
Elimination of residual magnetism;
Switching – in from H.V. side.

Methods For The Analysis Of Harmonics

1. Kalman filtering method
2. DFT method
3. FFT method

System Under Consideration

A simple system consisting a 3-phase source supplying 3 phase resistive loads through a 3-phase star-delta transformer has been considered.

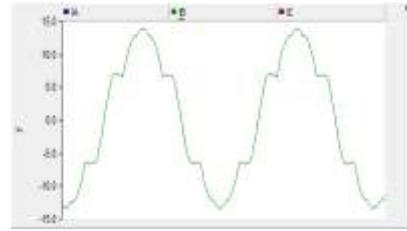
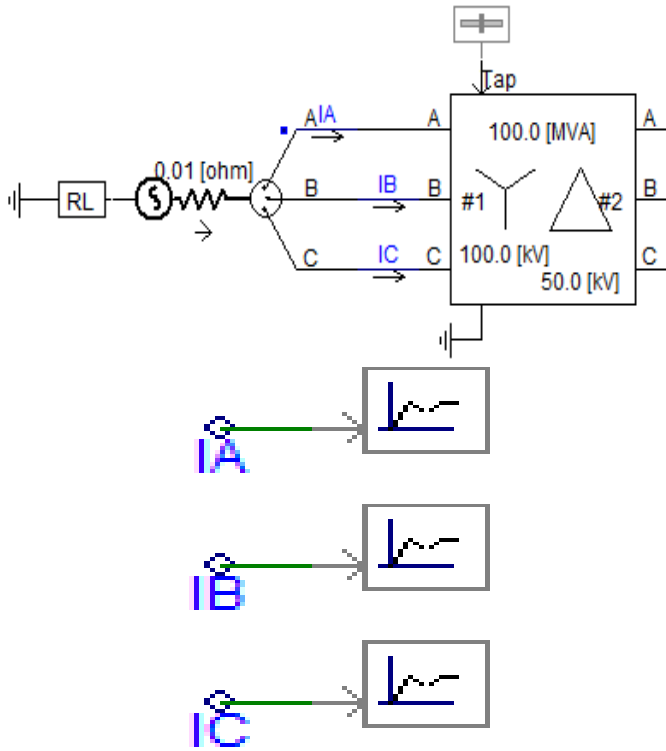

Steady – state characteristics of current of phase-B (IB).

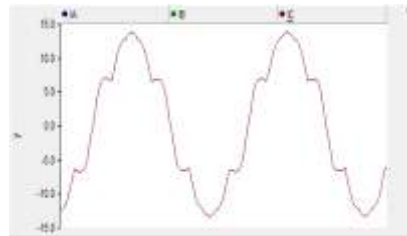

Steady – state characteristics of current of phase-C (IC).

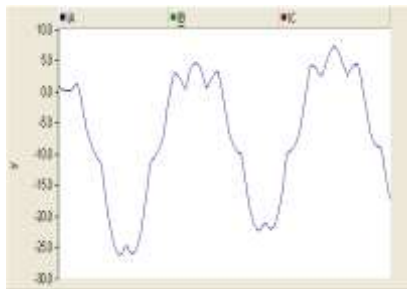

Transient characteristics of current of phase-A (IA).

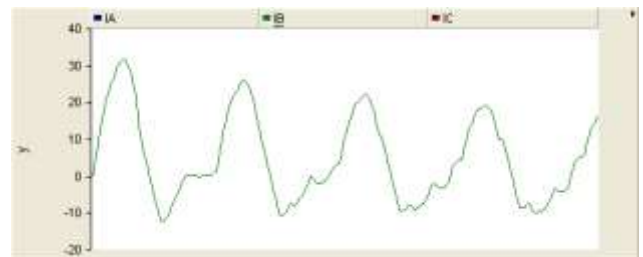

Transient characteristics of current of phase-B (IB).

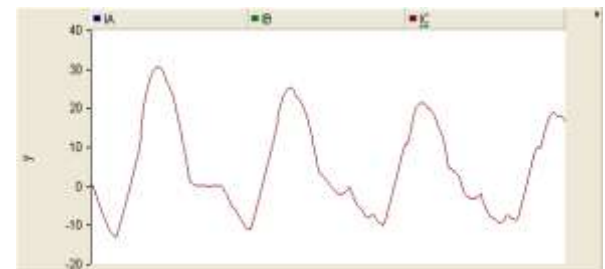

Transient characteristics of current of phase-C (IC).

Online Frequency Scanner

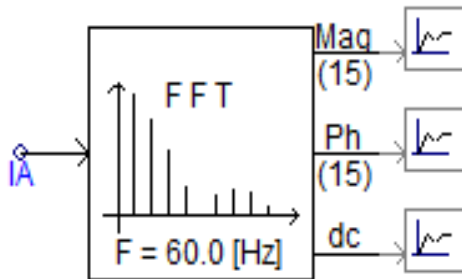

III. RESULTS

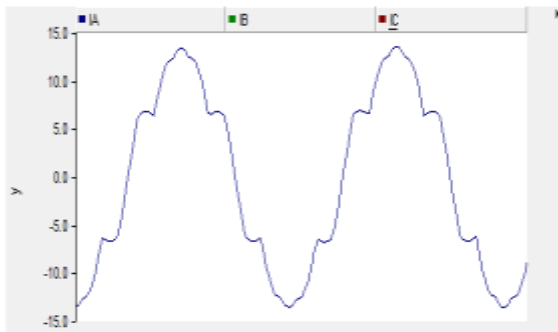

Steady – state characteristics of current of phase-A (IA).

Using FFT box in PSCAD the harmonics are analyzed. The results have been shown in the following figure.

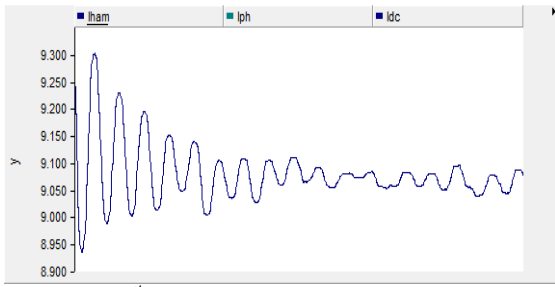

1st harmonic current when $n=1$

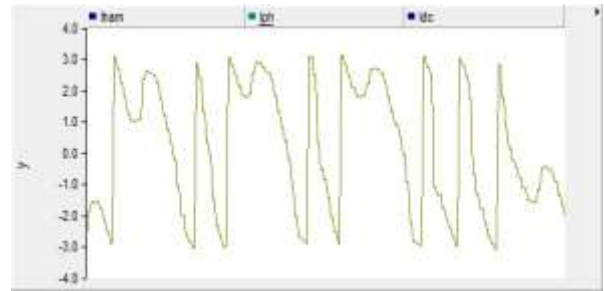

3rd phase current, when, $n = 3$.

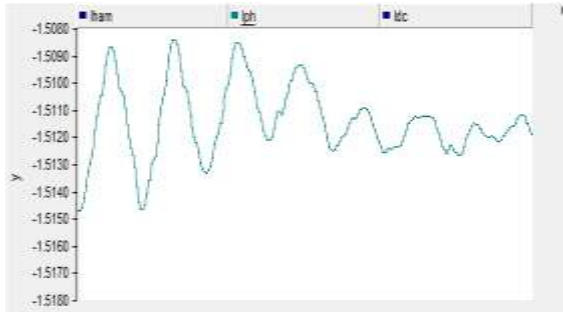

1st phase current, when, $n = 1$

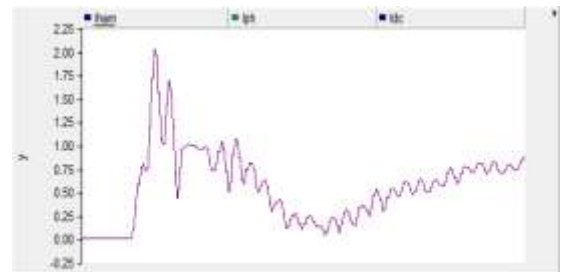

5th harmonic current, when, $n = 5$

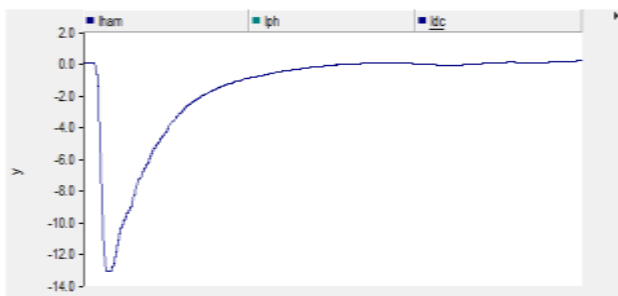

1st DC component, when, $n = 1$

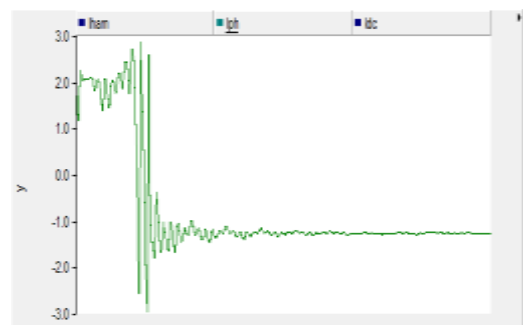

5th phase current, when, $n = 5$

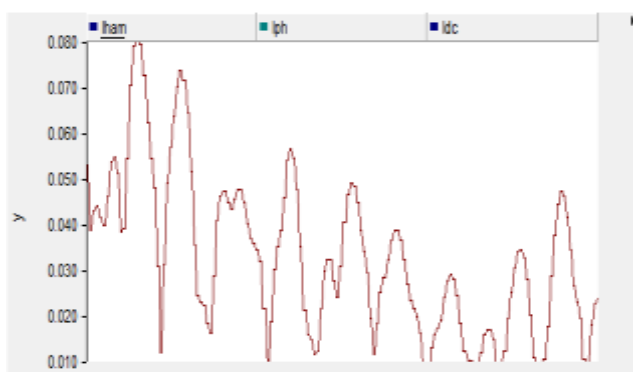

3rd harmonic current, when, $n = 3$.

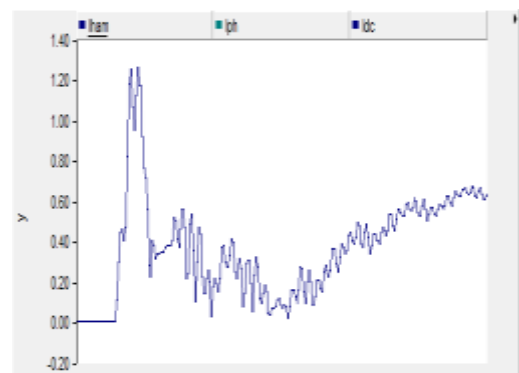

7th harmonic current, when, $n = 7$

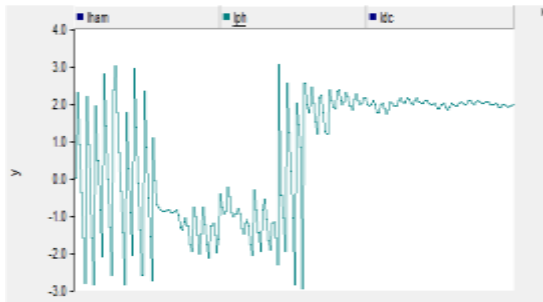

7th phase current, when, $n = 7$

Harmonic Analysis Of Fault (Symmetrical) Current With Fft

System Under Consideration

A simple system consists of a 3-phase source supplying through a 3-phase star-delta transformer has been considered as shown in the following figure.

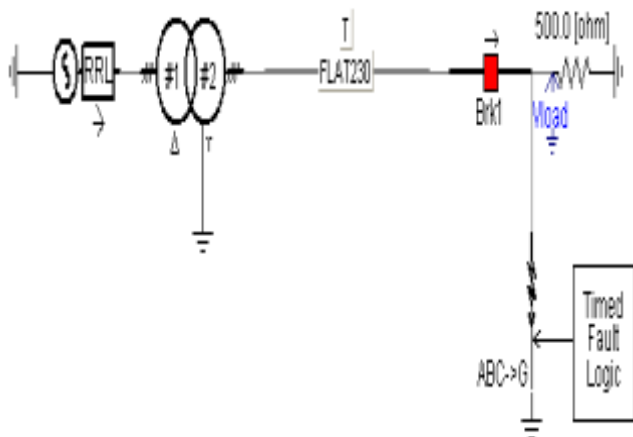

Fault current characteristics

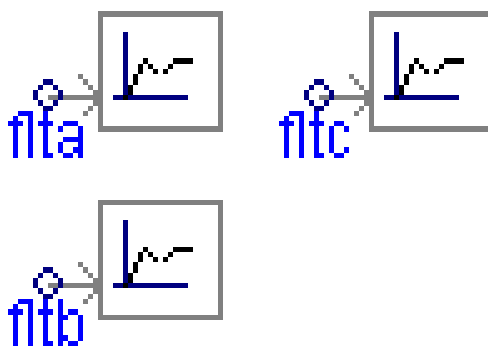

FFT analysis of three fault currents

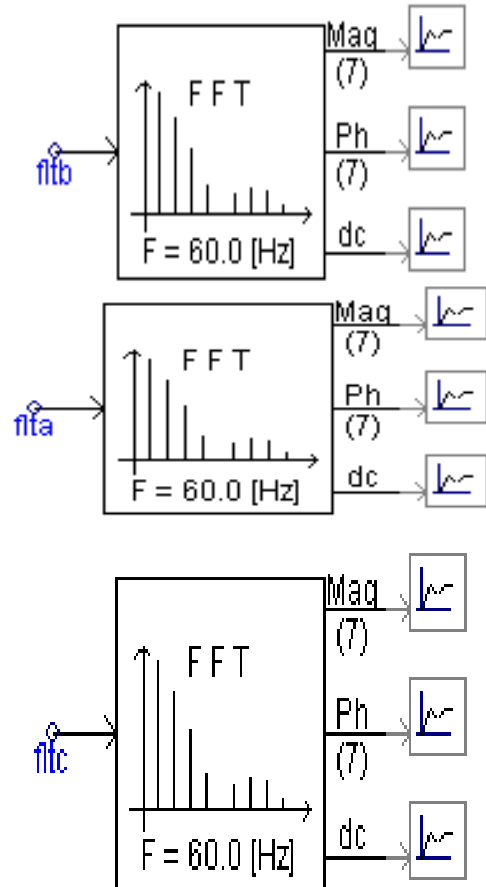

Results

The different characteristics of fault currents i.e., phase – A, phase – B & phase - C of the system shown in the above figure have been drawn graphically in the following figures.



Characteristics of fault current phase-A.

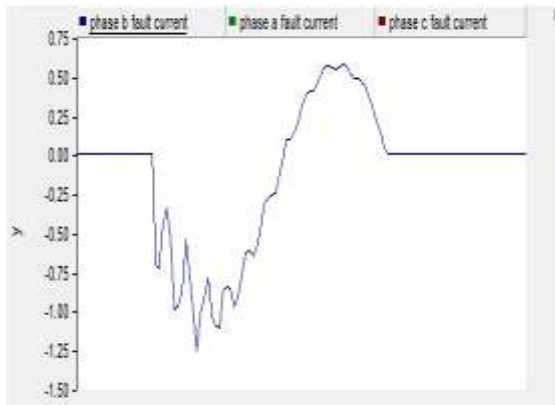

Characteristics of fault current of phase-B

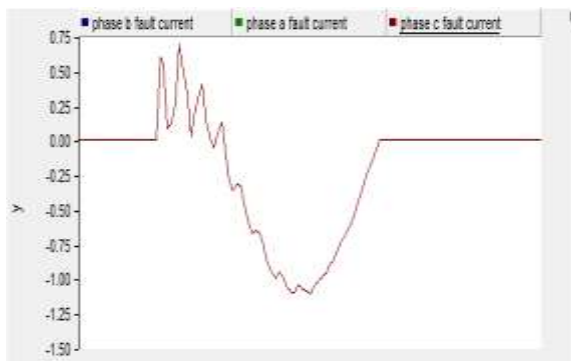

Characteristics of fault current of phase-C

IV. CONCLUSION:

Higher value of harmonics is present in inrush current but harmonics present in fault current is low valued in nature and it is also clear from the FFT analysis.

V. REFERENCE

- [1]. The performance and design of alternating current machines by M. G. Say.
- [2]. PSCAD software (Student version).
- [3]. Wikipedia.

IJEAST

INTERNATIONAL JOURNAL
OF ENGINEERING APPLIED SCIENCE
AND TECHNOLOGY

ABOUT IJEAST

International Journal of Engineering Applied Science and Technology (IJEAST) is a peer-reviewed, open access journal that publishes high-quality research papers in the field of Engineering, Applied Science and Technology.

IJEAST aims to provide a platform for researchers, academicians, and professionals to share their innovative ideas, research findings, and practical experiences with the global scientific community.

FOCUS AREAS

- Engineering
- Applied Science
- Technology
- Innovation & Development
- Interdisciplinary Studies



PEER REVIEWED

All submissions are rigorously peer reviewed to ensure quality.



OPEN ACCESS

Free and unrestricted access to research for all.



GLOBAL REACH

Connecting researchers and professionals worldwide.



TIMELY PUBLICATION

We ensure a swift and efficient publication process.



For more information, visit our website

www.ijeast.com



INTERNATIONAL JOURNAL
OF ENGINEERING APPLIED SCIENCE
AND TECHNOLOGY

✉ editor@ijeast.com

🌐 www.ijeast.com

📍 India



2455-2143