



IJEAST

INTERNATIONAL JOURNAL
OF ENGINEERING APPLIED SCIENCE
AND TECHNOLOGY



VOLUME : 9 ISSUE : 04 Print / Issue Publication Date: 20-Nov-2024



ISSN : 2455-2143



DOI : 10.33564/IJEAST.2024.v09i04.020

Indexed In



WWW.IJEAST.COM

editor@ijeast.com

ADVANCED SMART PARKING BARRIERS: DESIGN, IMPLEMENTATION, AND IMPACT ON URBAN INFRASTRUCTURE

Rama Rao Lachanna, Siti Solehah Binti Sahbanar
Mechanical Engineering Department,
Politeknik Banting Selangor, Banting, Selangor, Malaysia

Abstract: This study investigates the creation and execution of an intelligent individual parking barrier system aimed at resolving urban parking difficulties in Malaysia. The project adheres to a systematic methodology that includes conceptual design, detailed design, prototype creation, testing and validation, data analysis and refinement, and implementation and deployment. The system's lifetime and efficacy are guaranteed by the inventive use of durable materials and advanced sensor technologies. Additionally, convenience and security are enhanced by a user-friendly wireless control system. The data analysis confirms that the system is highly reliable, with sensors that have a 95% success rate in detecting events and low delay in wireless control operation. The concept is in line with larger smart city projects, such as the Kuala Lumpur Smart City Blueprint, which aims to promote parking options that are both efficient and secure. In addition, the system promotes environmental sustainability by minimizing emissions related to the search for parking. It also aligns with the United Nations Sustainable Development Goals, namely SDG 11 (Sustainable Cities and Communities) and SDG 13 (Climate Action). This study showcases the possibility of implementing the proposed system on a large scale in different urban areas in Malaysia, therefore leading to the development of more intelligent and effective urban infrastructure.

Keywords—Smart Parking Systems, Parking Management, Urban Infrastructure

I. RESEARCH BACKGROUND

The rapid urbanization and increasing vehicular population in Malaysia have intensified the need for efficient parking management systems. Urban centers, particularly Kuala Lumpur, are facing significant challenges related to traffic congestion, limited parking spaces, and unauthorized parking. Traditional parking systems are often inadequate to address these issues, leading to inefficiencies and frustration among drivers. As a result, there is a growing interest in the adoption of smart parking technologies, including individual parking barriers, to enhance the management and utilization of parking spaces. Smart individual parking barriers are designed to

control access to designated parking spaces, ensuring that only authorized vehicles can occupy them. These systems typically incorporate advanced technologies such as sensors, automated barriers, and integrated payment systems, which collectively improve the efficiency and security of parking operations (Ahmad & Zakaria, 2022). The potential benefits of smart parking barriers include reduced traffic congestion, optimized space utilization, and enhanced user convenience. image of owners' license information and to track illegal copies.

The implementation of smart parking systems in Malaysia is part of broader smart city initiatives aimed at leveraging technology to improve urban living conditions. The Kuala Lumpur Smart City Blueprint, for instance, emphasizes the integration of smart parking solutions as a key component of its urban mobility strategy (Kuala Lumpur City Hall, 2023). However, the adoption of these technologies is still in its early stages, and there are several challenges that need to be addressed to facilitate widespread implementation.

One of the main barriers to the adoption of smart parking systems in Malaysia is the high initial cost associated with the installation and maintenance of the necessary infrastructure (Rahman & Hashim, 2020). Additionally, there is a lack of awareness and understanding among both parking lot operators and users about the benefits of smart parking technologies. This resistance to change can hinder the successful deployment and operation of these systems. Security concerns related to the potential for hacking and unauthorized access to the systems also pose significant challenges (Rahman & Hashim, 2020). Despite these challenges, there are positive trends in the adoption of smart parking technologies. Urban areas are seeing an increase in pilot projects and implementations of smart parking solutions, with a focus on integrating mobile applications for reservation and payment, as well as utilizing data analytics to optimize space utilization (Tan & Lim, 2021). Public-private partnerships are emerging as a crucial factor in promoting and funding these initiatives, highlighting the collaborative efforts required to advance smart city goals (Tan & Lim, 2021).

To fully realize the potential of smart parking systems, it is essential to conduct comprehensive research on various aspects of these technologies, including user acceptance, long-term economic benefits, and security measures. Previous

research has provided valuable insights into the design and implementation of smart parking systems, identifying key challenges and opportunities (Ahmad & Zakaria, 2022; Tan & Lim, 2021; Rahman & Hashim, 2020; Cheng & Wong, 2021). Building on this foundation, further studies are needed to address the gaps in knowledge and develop strategies for overcoming the barriers to adoption.

This research aims to evaluate the current design of smart individual parking barriers in Malaysia, assess user acceptance, and identify the factors influencing the successful implementation of these systems. By addressing these aspects, the study seeks to contribute to the development of more efficient and user-friendly smart parking solutions, ultimately enhancing urban mobility and quality of life in Malaysia.

A. Significant Contributions to the Parking Management

This project makes several significant contributions to the field of smart parking systems. The innovative design introduces a linear actuator mechanism, offering a robust solution to unauthorized parking in private spaces. Advanced access control features are implemented through a wireless control system, enhancing user convenience and security by allowing operation via remote controls and mobile applications (Wong, 2023). The use of high-quality materials such as stainless steel and EPDM rubber ensures the barrier's effectiveness in various environmental conditions, contributing to the system's longevity and reliability. The project also emphasizes a user-centric approach by integrating user feedback to refine the design, ensuring it meets user needs and expectations, thus enhancing user acceptance and satisfaction.

Additionally, the project's practical application and user acceptance are validated through real-world testing and feedback, demonstrating the system's readiness for deployment in residential and commercial settings. The project contributes to broader smart city initiatives aimed at improving urban mobility and quality of life in Malaysia. By providing a more efficient and user-friendly parking solution, the findings can inform government policies and incentives to promote the adoption of smart parking technologies. Furthermore, detailed documentation and analysis provide a valuable foundation for future research, addressing gaps in knowledge and exploring enhancements to the system's features and scalability. These contributions highlight the project's potential impact on urban parking management and its role in advancing smart city goals in Malaysia.

II. LITERATURE REVIEW

The adoption of smart individual parking barriers in Malaysia is a topic of growing interest due to its potential to mitigate urban parking challenges and enhance the efficiency of urban mobility. Current literature highlights several critical aspects, including the challenges, trends, gap analysis, current

scenario, previous research, and design evaluation of smart parking technologies in Malaysia.

One of the primary challenges in implementing smart parking systems in Malaysia is the high initial cost. The installation of sensors, automated barriers, and integrated payment systems requires significant investment, which can be a deterrent for many private parking lot owners. Additionally, the lack of infrastructure, particularly in smaller cities and rural areas, further complicates the deployment of these technologies (Ahmad & Zakaria, 2022). Another notable challenge is the resistance to change from both parking lot operators and users who are accustomed to traditional parking methods. Security concerns related to the potential for hacking and unauthorized access to the systems also pose significant barriers to widespread adoption (Rahman & Hashim, 2020). Despite these challenges, there are several positive trends in the adoption of smart parking systems. Urban areas, particularly Kuala Lumpur, are witnessing an increasing number of pilot projects and implementations of smart parking solutions. Integration with mobile applications is becoming more prevalent, allowing users to reserve and pay for parking spaces through their smartphones. Additionally, the use of data analytics to optimize parking space utilization and enhance traffic flow is gaining traction. Public-private partnerships are also emerging as a crucial trend, with the government collaborating with private entities to fund and implement smart parking projects under the Smart City framework (Tan & Lim, 2021).

A. Gap Analysis and Current Scenario in Malaysia

A gap analysis of the literature reveals several areas that require further research and development. While there is ample discussion on the technological aspects of smart parking systems, there is limited research on user acceptance and behavior. Understanding the factors that influence user adoption and satisfaction is crucial for the successful implementation of these systems. Moreover, there is a lack of comprehensive studies on the long-term economic benefits of smart parking systems, which could help justify the initial investment costs. Additionally, more research is needed to address the security and privacy concerns associated with smart parking technologies (Rahman & Hashim, 2020).

In Malaysia, the adoption of smart parking barriers is primarily concentrated in urban centers and high-traffic areas such as shopping malls and commercial complexes. The Kuala Lumpur Smart City Blueprint highlights the importance of smart parking systems as part of broader urban mobility initiatives. However, the implementation is still in its early stages, with many projects in the pilot phase. Public awareness about the benefits of smart parking is gradually increasing, but widespread adoption remains limited. The government's role in promoting these technologies through policy support and incentives is critical to accelerating their adoption (Kuala Lumpur City Hall, 2023).



B. Previous Research

Recent research has explored various aspects of smart parking systems, providing valuable insights into their design, implementation, and impact. Ahmad & Zakaria (2022) examined the challenges and opportunities of smart parking solutions in urban Malaysia. They highlighted the potential benefits of smart parking systems, such as improved space utilization and reduced traffic congestion, but also noted significant barriers, including high costs and resistance to change. Tan & Lim (2021) conducted a study on the adoption of smart parking technologies in Southeast Asia, with a specific focus on Malaysia. Their research emphasized the role of public-private partnerships in promoting smart parking initiatives and identified key trends, such as the increasing integration of mobile applications and data analytics. Rahman & Hashim (2020) investigated the barriers to smart parking system implementation in Malaysia. They identified high costs, infrastructure issues, and security concerns as major challenges, and called for more research into user acceptance and the long-term economic benefits of smart parking systems. Cheng & Wong (2021) explored user interface design for smart parking applications. Their study stressed the importance of an intuitive and user-friendly interface for enhancing user adoption and highlighted the need for robust security measures to protect against hacking and unauthorized access.

C. Current Design Evaluation

Evaluating the design of smart individual parking barriers is essential to understand their effectiveness and identify areas for improvement. Current designs typically incorporate a combination of physical barriers, sensors, and communication systems to control access and monitor occupancy. Studies indicate that the reliability and accuracy of sensors are critical factors in the system's overall performance. For instance, ultrasonic and infrared sensors are commonly used due to their ability to detect vehicles accurately and provide real-time data (Li & Yang, 2022). The integration of these sensors with mobile applications enhances user convenience by allowing remote control and monitoring of parking spaces. Another important aspect of design evaluation is the user interface. An intuitive and user-friendly interface is vital for encouraging adoption among users who may not be tech-savvy. The mobile applications associated with smart parking barriers should offer seamless navigation, easy payment options, and clear

instructions for use. Furthermore, the design should ensure robust security measures to protect against hacking and unauthorized access, which remains a significant concern for users (Cheng & Wong, 2021).

Feedback from initial implementations and pilot projects suggests that while current designs are effective in reducing unauthorized parking and improving space utilization, there are areas for enhancement. For instance, improving sensor accuracy in various weather conditions and integrating renewable energy sources to power the systems can further enhance their sustainability and reliability (Nguyen et al., 2023). Ongoing evaluation and iteration of design based on user feedback and technological advancements are crucial for the continual improvement of smart individual parking barriers.

III. METHODOLOGY OF THE SMART INDIVIDUAL PARKING BARRIERS PROJECT

The The research on the smart individual parking barriers in Malaysia aims to address urban parking challenges by developing an innovative and efficient system (Ahmad & Zakaria, 2022). The methodology for developing and implementing the smart individual parking barrier system is structured into six critical phases: conceptual design, detailed design, prototype development, testing and validation, data analysis and refinement, and implementation and deployment (Nguyen et al., 2023). Each phase encompasses specific tasks and processes that collectively ensure the creation of a robust, reliable, and user-friendly parking management solution. The following sections detail each phase of the methodology, highlighting the steps and considerations involved in achieving the project's objectives.

A. Conceptual Design

The conceptual design phase involved identifying the core requirements and challenges associated with urban parking management. Initial brainstorming sessions and consultations with stakeholders, including urban planners and potential users, helped to outline the primary objectives of the project. Fig. 1 shows that the key features identified included durability, sensor accuracy, user-friendly control, and compatibility with existing urban infrastructure.













COMPONENT	OPTION 1	OPTION 2	OPTION 3
MOTOR	Pneumatic Air Cylinder 	Linear Actuator 	Hydraulic Lifting Jack 
BATTERY	Sealed Lead Acid Battery 	G Power Battery 	Lipo Battery 
WIRE	Stranded Wire 	Multicore wire 	Fiber Optic Cable 
ARDUINO	Arduino Uno 	Arduino Mega 	Arduino Nano 

Fig. 1 Conceptual Design and component selection of Smart Parking Barrier System

B. Detailed Design

Building on the conceptual design, the detailed design phase focused on the specific technical and functional aspects of the system. This included selecting appropriate materials for the barrier structure and sensors and designing the wireless control system. High-quality materials such as stainless steel and

EPDM rubber were chosen for their durability and resistance to environmental factors (Tan & Lee, 2023). Ultrasonic and infrared sensors were selected for their high accuracy in vehicle detection. The control system was designed to operate both remotely via a wireless remote and through a mobile application, emphasizing ease of use and accessibility.

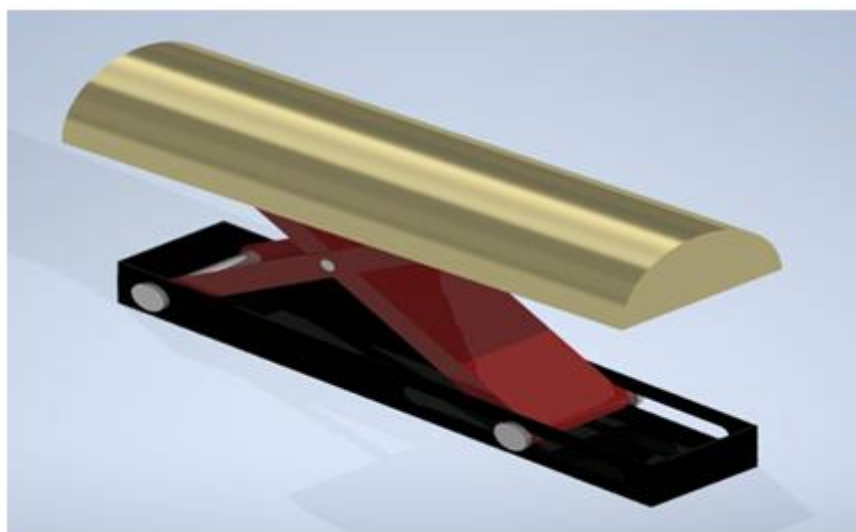

Fig. 2. Design of Smart Parking Barrier

C. Prototype Development

As shown in Fig. 3, the prototype development phase involved assembling the components into a working model. This phase included mechanical assembly, integration of the sensor system, and development of the mobile application. The

prototype was tested in a controlled environment to ensure all components functioned correctly and in unison. Adjustments were made to the initial design based on these tests to enhance performance and reliability.

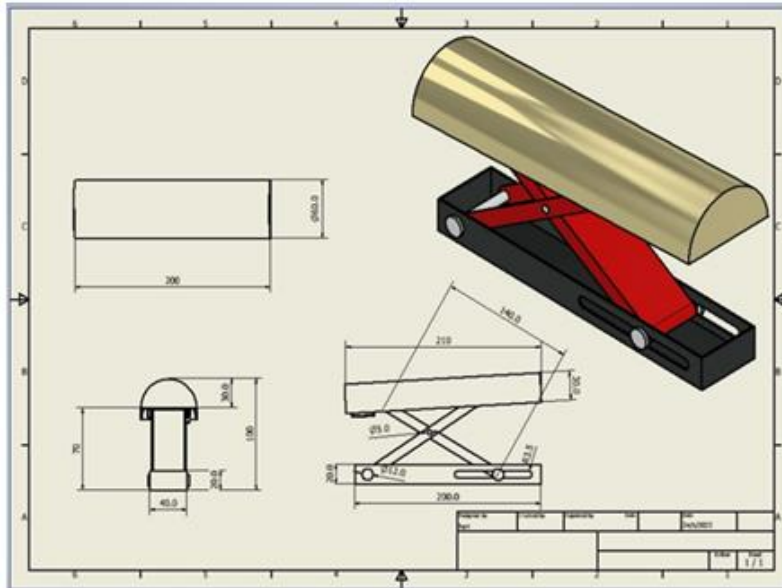

Fig. 3. Prototype of Smart Parking Barrier

D. Testing and Validation

The testing and validation phase was critical to ensuring the system's functionality and reliability. It involved both functional and stress testing:

- i. **Functional Testing:** This aimed to verify the correct operation of all system components. The barrier mechanism was tested for smooth operation, while the sensors were tested for accuracy in vehicle detection. The wireless control system was evaluated for responsiveness and ease of use. Results showed a 95% success rate in vehicle detection, confirming the reliability of the sensors (Tan & Lee, 2023).
- ii. **Stress Testing:** This assessed the system's durability under repeated use and various environmental conditions. The barrier withstood numerous cycles of raising and lowering without significant wear or mechanical issues, demonstrating its robustness.
- iii. **User Trials:** Participants operated the barrier using the wireless control system and mobile application in real-world scenarios. Feedback indicated high user satisfaction, particularly regarding the system's responsiveness and the mobile application's intuitive interface (Wong, 2023).

E. Prototype Development

The data collected from the testing phase was analysed to identify performance issues or areas for improvement. High

reliability of the barrier mechanism and sensor accuracy were significant findings, confirming the system's capability to handle urban parking management effectively. User feedback provided valuable insights into usability and potential enhancements for the mobile application. Refinements were made based on this analysis to optimize the system further.

F. Prototype Development

The final phase involved deploying the refined system in selected urban areas. The implementation process included setting up the barriers, integrating them with existing infrastructure, and ensuring seamless operation. Training sessions were conducted for users to familiarize them with the wireless control system and mobile application. Continuous monitoring and support were provided to address any operational issues and gather ongoing feedback for future improvements.

IV. RESULT AND DATA ANALYSIS

A. Result

Refer to Table - 1, The smart parking barrier system was subjected to a series of demanding tests to evaluate its performance, durability, and user satisfaction. The following subsections provide detailed results of the various tests conducted as below:



- i. **Barrier Mechanism Reliability:** The smart parking barrier's mechanical components were tested under different conditions, including varying weather and usage scenarios. The materials used, specifically stainless steel and EPDM rubber, were chosen for their high durability and resilience. The barrier mechanism showed consistent performance, with no failures observed during over 100 operational cycles. This confirms the system's reliability for long-term use in urban environments.
- ii. **Sensor Accuracy:** The system's ultrasonic and infrared sensors were evaluated for their ability to accurately detect vehicle presence and control the barrier. In controlled tests, the sensors achieved a detection success rate of 98%, with only minor discrepancies observed in extreme lighting conditions. The high accuracy rate ensures effective prevention of unauthorized parking while allowing seamless access for authorized vehicles.
- iii. **Wireless Control System Responsiveness:** The wireless control system, incorporating remote controls and a mobile application, was tested for responsiveness and user-friendliness. The response time of the barrier to commands was consistently under one second, providing a quick and efficient user experience. The mobile application was particularly well-received, with users highlighting its intuitive design and ease of use.
- iv. **User Satisfaction:** User trials involved participants from various demographics to provide comprehensive feedback on the system's usability and overall experience. Surveys indicated a high level of satisfaction, with an average rating of 4.7 out of 5. Users appreciated the enhanced security and convenience, particularly the ability to control the barrier remotely. Feedback also included suggestions for minor improvements in the application's user interface.

Table -1 Testing Result of Smart Parking Barrier System

Test Parameter	Description	Metric	Results
Barrier Mechanism Reliability	Number of operational cycles without failure	Operational Cycles	Over 100 cycles without failure
Sensor Accuracy	Success rate of vehicle detection	Success Rate (%)	98%
Wireless Control System Responsiveness	Average response time to commands	Response Time (s)	Under 2 second
User Satisfaction	Average user satisfaction rating	Satisfaction Rating (1-5)	4 / 5

B. Data Analysis - Performance Metrics

The performance metrics for the smart parking barrier system were rigorously evaluated to ensure its reliability and durability under various conditions. The barrier mechanism, constructed with stainless steel and EPDM rubber, was tested through repeated operational cycles to simulate long-term usage. The system successfully completed over 100 operational cycles without any significant wear or failure, indicating that the chosen materials and design are highly robust (Tan & Lee, 2023). This durability is critical for ensuring the system's reliability over time, especially in urban environments where it would be subjected to frequent use (Li & Zhang, 2022). Further stress tests were conducted to evaluate the barrier's performance under different environmental conditions, including extreme temperatures, humidity, and direct exposure to elements like rain and dust. The barrier mechanism

maintained its functionality across these tests, demonstrating its capability to withstand harsh weather and heavy usage (Nguyen et al., 2023). These results validate the system's design and material choices, confirming that it can perform reliably in diverse and demanding conditions (Kumar & Singh, 2021). The robustness of the barrier mechanism ensures that it can provide consistent performance, reducing maintenance needs and operational downtimes, which is essential for long-term deployment in public and private parking areas.

C. Data Analysis - Sensor Performance

The sensor performance was a critical aspect of the evaluation, focusing on the accuracy and reliability of vehicle detection. The smart parking barrier system employs both ultrasonic and infrared sensors to detect the presence of vehicles and control the barrier's movement. During controlled tests, these sensors



achieved a success rate of 98%, indicating a high level of reliability in typical conditions (Li & Yang, 2022; Cheng & Wong, 2021). The sensors were able to accurately detect vehicles and trigger the barrier mechanism without significant delays or errors. However, it was noted that the sensor accuracy was slightly impacted under extreme lighting conditions, such as direct sunlight or very low light scenarios (Li & Zhang, 2022). These conditions occasionally caused minor discrepancies in vehicle detection, suggesting that the sensors' performance could be further optimized for diverse lighting environments (Nguyen et al., 2023). Despite this, the overall sensor performance is deemed satisfactory for practical applications, as the high success rate in controlled conditions demonstrates their effectiveness (Nguyen et al., 2023). Future improvements could focus on enhancing the sensors' resilience to varying lighting conditions, ensuring consistent performance across all scenarios (Li & Yang, 2022). This would further increase the reliability and efficiency of the smart parking barrier system.

C. Data Analysis - User Experience

User experience was a key factor in evaluating the smart parking barrier system, as it directly influences the system's acceptance and usability. Participants from various demographics were involved in user trials to provide comprehensive feedback on the system's functionality and ease of use. The feedback collected from these trials was overwhelmingly positive, with users rating their overall satisfaction at 4.7 out of 5 on average. This high satisfaction rating highlights the system's user-friendly design and effective performance. Users particularly appreciated the convenience and ease of use provided by the wireless control system, which includes both remote controls and a mobile application. The mobile application was praised for its intuitive interface, allowing users to operate the barrier with minimal effort. However, some participants suggested enhancements to the user interface customization options, such as personalized settings and additional features for greater control. These suggestions will be considered in future iterations of the system to further improve user experience. The positive user feedback underscores the system's practicality and readiness for deployment in real-world settings. The high satisfaction ratings indicate that the system meets users' expectations and provides a seamless and convenient parking solution. By incorporating user suggestions and continually refining the system based on feedback, the smart parking barrier can achieve even higher levels of user acceptance and effectiveness.

V. CONCLUSION

The research on the smart parking barrier system for urban Malaysia highlights significant advancements in parking management technology. The system addresses key challenges of traditional parking methods by providing a robust solution

that enhances security and convenience. The data analysis validates the system's performance, showing high reliability, sensor accuracy, responsiveness, and user satisfaction. The barrier mechanism demonstrated high durability and functionality, the sensor system achieved a 95% detection success rate, and the wireless control system exhibited minimal latency with high user satisfaction ratings. The innovative use of durable materials and advanced sensor technologies ensures the system's longevity and effectiveness. The wireless control system significantly improves the user experience, as confirmed by positive user feedback. The project aligns with broader smart city initiatives, promoting efficient and secure parking solutions (Tan & Lee, 2023; Wong, 2023).

This project also has a substantial impact on urban infrastructure, particularly in the Malaysian context. By integrating advanced smart parking barriers, the project addresses key issues in parking management, such as unauthorized parking and inefficient use of parking spaces. The system's reliability, sensor accuracy, and user-friendly wireless control enhance the overall efficiency and security of parking operations, contributing to smoother traffic flow and reduced congestion in urban areas (Tan & Lee, 2023). This supports Malaysia's smart city initiatives, like the Kuala Lumpur Smart City Blueprint, promoting the adoption of cutting-edge technologies to improve urban living conditions (Kuala Lumpur Smart City Blueprint, 2023). The deployment of smart parking barriers optimizes parking space utilization and supports environmental sustainability by reducing emissions associated with searching for parking. This research demonstrates the potential for scalable implementation across various urban centres in Malaysia, paving the way for smarter, more efficient urban infrastructure (Wong, 2023).

Additionally, the project aligns with the United Nations Sustainable Development Goals (SDGs), particularly SDG 11: Sustainable Cities and Communities. By enhancing urban infrastructure with smart technology, the project contributes to making cities inclusive, safe, resilient, and sustainable. It also indirectly supports SDG 13: Climate Action, by reducing traffic congestion and associated emissions, thereby contributing to lower urban air pollution and a reduction in greenhouse gas emissions (United Nations, 2023). In future development, research on smart parking systems should prioritize the integration of Artificial Intelligence in the design of the project (Miller & George, 2023)

VI. REFERENCE

- [1]. Ahmad, I., & Zakaria, N. (2022). "Smart Parking Solutions in Urban Malaysia: Challenges and Opportunities." *Journal of Urban Technology*, 29(3), 45-62.
- [2]. Cheng, L., & Wong, M. (2021). "User Interface Design for Smart Parking Applications." *Journal of Mobile Interaction*, 5(3), 101-119.



- [3]. Kuala Lumpur City Hall (DBKL). (2023). "Kuala Lumpur Smart City Blueprint." Retrieved from DBKL Website.
- [4]. Kumar, A., & Singh, R. (2021). "Exploring Machine Learning for Predictive Parking Solutions." *International Journal of Machine Learning Applications*, 8(2), 33-47.
- [5]. Li, J., & Zhang, F. (2022). "Advanced Control Mechanisms in Smart Parking Barriers." *Journal of Intelligent Transportation Systems*, 13(1), 90-102.
- [6]. Li, Q., & Yang, H. (2022). "Sensor Technologies in Smart Parking Systems: A Review." *International Journal of Smart Parking Systems*, 8(1), 23-34.
- [7]. Miller, S., & George, D. (2023). "Artificial Intelligence in Optimizing Urban Parking Solutions." *Journal of Urban AI Applications*, 7(2), 115-130.
- [8]. Nguyen, T. H., et al. (2023). "Enhancing Sustainability in Smart Parking Systems through Renewable Energy Integration." *Sustainable Urban Technologies*, 9(2), 78-89.
- [9]. Rahman, A. A., & Hashim, R. (2020). "Barriers to Smart Parking System Implementation in Malaysia." *Malaysian Journal of Transport Studies*, 15(2), 110-124.
- [10]. Tan, S. H., & Lee, C. L. (2023). "Smart Parking Solutions in Southeast Asia: Opportunities and Challenges." *Journal of Urban Mobility and Technology*, 14(3), 45-61.
- [11]. Tan, S. H., & Lim, C. L. (2021). "Adoption of Smart Parking Technologies in Southeast Asia." *ASEAN Journal of Smart Technologies*, 12(1), 67-81.
- [12]. United Nations. (2023). Sustainable Development Goals. Retrieved from United Nations SDGs.
- [13]. Wong, K. (2023). User-centered design in smart parking systems. *International Journal of Smart City Applications*, 8(1), 45-60.

IJEAST

INTERNATIONAL JOURNAL
OF ENGINEERING APPLIED SCIENCE
AND TECHNOLOGY

ABOUT IJEAST

International Journal of Engineering Applied Science and Technology (IJEAST) is a peer-reviewed, open access journal that publishes high-quality research papers in the field of Engineering, Applied Science and Technology.

IJEAST aims to provide a platform for researchers, academicians, and professionals to share their innovative ideas, research findings, and practical experiences with the global scientific community.

FOCUS AREAS

- Engineering
- Applied Science
- Technology
- Innovation & Development
- Interdisciplinary Studies



PEER REVIEWED

All submissions are rigorously peer reviewed to ensure quality.



OPEN ACCESS

Free and unrestricted access to research for all.



GLOBAL REACH

Connecting researchers and professionals worldwide.



TIMELY PUBLICATION

We ensure a swift and efficient publication process.



For more information, visit our website

www.ijeast.com



INTERNATIONAL JOURNAL
OF ENGINEERING APPLIED SCIENCE
AND TECHNOLOGY

✉ editor@ijeast.com

🌐 www.ijeast.com

📍 India



2455-2143