



IJEAST

INTERNATIONAL JOURNAL
OF ENGINEERING APPLIED SCIENCE
AND TECHNOLOGY



VOLUME : 6 ISSUE : 10 Print / Issue Publication Date: 21-Apr-2022



ISSN : 2455-2143



DOI : 10.33564/IJEAST.2022.v06i10.020

Indexed In



WWW.IJEAST.COM

editor@ijeast.com



DESIGN AND DEVELOPMENT OF MGIRI MODIFIED NMC CHARKHA

Sachin Raut, Deep Varma, Shubham Chaudhary, Ravikumar Kandasamy, Ganesh There
Rural Energy & Infrastructure Department
MGIRI, Wardha, Maharashtra, India

Abstract—Charkha is a small spinning device produces yarns from fibers, which can be used to make clothes. The demand for cotton fabrics in the modern world has increased the production of cotton fabrics, making them more readily available. To increase production, charkhas are operated on electricity or on a battery-operated system. There is no reliable electricity available in most of India's rural areas. Due to low population density, there is much expense associated with installing and maintaining transmission lines. As a result, some areas will lack access to reliable electricity. For the elimination of manual labour operation of charkha by using electricity is the simplest option. However, there are some issues, like the yarn produced by using electrically operated charkha does not meet the definition of khadi that is the reason the option of using electrically operated charkha is not taken significantly. A detailed study was carried out on the design and analysis of the MGIRI modified NMC charkha. The basic necessity of this study is to enhance income and reduce drudgery. Efforts have been made to modify the existing design in order to increase productivity and ease of use. In the design, the mode and means of motion transmission have been redesigned. Reduction in rotating elements (gears and pulleys), the addition of bearings, and reduction in the weight of the machine have been undertaken.

Keywords—NMC Charkha, Khadi, Drudgery, Productivity, Redesigned

I. INTRODUCTION

A turning wheel or charkha is a device for turning yarn from natural or synthetic fibres. The most precise and clear depictions of the turning wheel come from Baghdad (attracted 1237), China (1270), and Europe (1280), and there is evidence that turning wheels were already in use in both China and the Islamic world during the 11th century. A spinning wheel was brought to India from Iran in the thirteenth century, according to writing. The spinning wheel supplanted the preceding technique of hand spinning with a spindle. The main level in automating the interaction becomes mounting the spindle horizontally so it could be circled by way of a cord encircling a large, hand-driven wheel. In an example of this kind, the great wheel holds the fiber in the left hand while turning

steadily with the right. Keeping the fiber at a slight point in opposition to the spindle produced the important twist. In order to wound the yarn onto the spindle, it was moved so that it formed a right angle with the spindle.

The charkha is designed to produce yarn by means of the manner called turning or spinning. The word charkha means wheel and it is being used for spinning the rowing cotton into thread. Charkhas are available in 1, 2, 4, 6 and 8 spindle models. Hand powered charkhas are powered by the spinner rotating a handle with their hand, as opposed to pressing pedals or using a mechanical engine. New Model Charkha (NMC) is exceptionally famous across the country (India) for delivering coarse to fine-count cotton, blended and worsted yarns. This machine consisting of 8 spindles is turned by hand in a sitting posture by the operator.

The departments of MGIRI work on their research and provide the solution on problems arises in the small-scale industries. RE&I (Rural energy and infrastructure) department of MGIRI act as a technical agency to support various small-scale industries. MGIRI's RE&I department has come up with an improved version of NMC with changing mean and mode of motion transmission by transmitting power with the help of chain sprocket arrangement to significant reduction in torque for operating the charkha also Reduction in rotating elements (gears and pulleys), addition of bearings, these changes brought by the department helps to reduce the drudgery of the operator and improvement in the strength of yarn.

1.1 Yarn production through pollution free hand driven energy

In a motorized or mechanized spinning factory, 221.1kWh of energy is consumed per 1000 spindles, out of which 69% is consumed in the ring frame area and the cooling or air-conditioning section. The required energy to spin ring yarn varies between 3.49 and 3.62 kWh/kg. A large part of this energy can be saved through charkha spinning system. Very low power is required to operate the charkha, higher cost effectiveness with better returns on investment.

1.2 Definition of Khadi

A lot has been talked and examined about Khadi. Some associate it with the freedom movement and the Gandhian way of thinking. Others accept it as our future means to a feasible economy. Leaving aside all philosophical implications. Khadi

fabric can be essentially clarified as a piece of fabric made in India by hand. That said, Khadi, of course, ought to be handspun and hand woven. Just like all squares are rectangles, but not all rectangles are square. All Khadi is handloom, yet not all handloom fabric can qualify as Khadi. While, it is vital for Khadi fabrics to be made utilizing handspun yarn, no such foundation is put on handloom fabric. Which suggests that any sort of yarn (mill made, man-made, normal, handspun) can be used on a handloom to make a length of fabric.

II. MGIRI MODIFIED NMC CHARKHA

The New Modified charkha is shown in above figure1. This 8-spindle charkha consists of chain sprocket arrangement to perform the operation of yarn production. There is a lot of traction in India for the production of coarse to fine count cotton, blended yarns and worsted yarns with New Model Charkha (NMC).



Figure 1: New Modified charkha

This micro size machine consisting of six to eight spindles is turned by hand in a sitting posture by the village women. The earnings made by producing yarns help in supplementing the income of the family and empower the village women. To enhance income and reduce drudgery, an effort has been made to improve productivity and ease of operation by suitably modifying the existing design. In the design, mode and means of motion transmission have been redesigned. Reduction in rotating elements such as gears and pulleys, addition of



Figure 1.1: Side view of New Modified charkha

bearings, and stabilizing rail movement have been undertaken. Due to neglecting some power transmission gears and pulleys by using simple transmission of chain drive the weight and cost of charkha is also reduced. The MGIRI modified charkhas have received positive feedback from the users.

III. WORKING PRINCIPLE OF MGIRI MODIFIED NMC CHARKHA

When the handle is turned, its movement is transferred to different parts through the chain drive and pulleys. Charkhas use roving/sliver as input material, which contains a large number of fibres in its cross-section. Drafting affects the decrease of fibres in the cross-section. 3-line single-apron drafting system is used in charkha. A steel fluted base roller and a weighted high-pressure roller grip the fibres tightly during drafting. The pressure is applied by the spring weighing system. The roller sets turn at a steady speed, resulting in a resultant stretch (i.e. draft) in the material nipped between the rollers. The controlled two stage extending activities (i.e., drafting) stretch the feed roving and carry it to the necessary yarn dimension according to the perspective of mass per unit length. In order to give the fibre matrix strength, the drafted item must be turned when it rises out of the nip of the front pair of rollers. Ring and traveller work in conjunction to create a twist. There is a loop of wire attached loosely to the circular ring, which is free to move around it and acts as a traveller. A spindle holding the package (bobbin) turns a ring, causing the traveller to turn. The spindle imparts force on the traveller due to the yarn loop between the front roller and the bobbin. It simultaneously winds the yarn around the package. Platforms are made to oscillate from bottom to top of the package with a certain frequency so that the ring rail is supported. With the ring rail moving up and down, the traveller follows the same path, and yarn is guided throughout the bobbin from top to bottom.

IV. DETAILED PART STUDY OF NMC CHARKHA.

1. To give strengthening and profitable work to more and needier individuals, particularly women's there is a need to further develop an improved version of the Charkha which will be more useful. NMC Charkha utilizes preferred elements which utilized inside the factories for turning yarn (ring frame, set of rollers with pressure arm, cam, etc.) A modular unit with six, eight or more spindles is assembled and driven by hand to create cotton yarn. Turning with Charkha is a much quicker process. There were different types of charkhas being used, but owing to simplicity in design and alongside the speed of production, the NMC Charkha became famous. (Please refer to Fig 2)
2. The raw material for the Charkha is known as "roving." By reducing the linear density of sliver roving is produced. Roving can be produced by hand also but, due to extended demand, these are produced in non-public or

co-operative turning factories managed via KVIC (Khadi and Village Industries Commission).

3. When the handle is rotated, its movement is transferred to various parts through chain drive, belts and Pulleys. The function of major parts is given below.
4. R1 Feed Roller Pair, A pair of feed rollers determines the feeding rate of the roving. (Ref fig 2)
5. R2 Extender Roller Pair; It opens, extends, and adjusts the fibers in the roving. (Ref fig 2)
6. R3 Throw Roller Pair; It decides the rate of formation of the yarn. (Ref fig 2)
7. Yarn Guide Hook; it allows the loose rotation and linear motion of the yarn.
8. Traveller; It enables the twisting and winding of the yarn on the bobbin.
9. Ring Frame; It holds and guides the traveller and allows in winding the Yarn on Bobbin.
10. Cam; this allows the follower lever to move up and down, thereby winding the yarn on the Bobbin uniformly.

$$\text{Power} = \frac{2\pi NT}{60}$$

$$= \frac{2\pi * 68 * 5.4}{60} \dots\dots\dots (N= 68 \text{ rpm of handle in loading condition})$$

P = 38.45 watt

Rated Power = 38.45 watt

2.Design of Chain drive for transmitting power from handle shaft to cam shaft.

Design Power = PR * KI(KI load factor refer table XIV-2 of D.D.B)

$$P = 38.45 * 1.4 \text{ (KI = 1.4 for moderate shock \& 24 Hrs-day service)}$$

$$P = 53.83 \text{ watt}$$

RPM of Smaller Sprocket = 75 rpm

From fig 14.1 of design data book by B D Shiwalkar
 For Design Power = 53.83 watt & RPM = 75
 Pitch = 6.25 mm

T1 (teeth of smaller sprocket) =17

Pitch Diameter of Sprocket

$$Dp1 = \frac{\text{Pitch}}{\sin \frac{180}{T1}} \dots\dots\dots (\text{From table XIV-1 D.D.B})$$

$$= \frac{6.25}{\sin \frac{180}{17}}$$

Dp1 = 34.01

$$\text{Pitch line velocity} = \frac{\pi D N}{60}$$

$$= \frac{\pi * 34.01 * 10^{-3} * 75}{60} \dots (N= 75 \text{ rpm ratio of drive and driven is calibrated to get 70-75rpm})$$

$$Vp1 = 0.1335 \text{ m/s}$$

$$= 8.01 \text{ m/min}$$

Power capacity of roller chain as per ASA standards

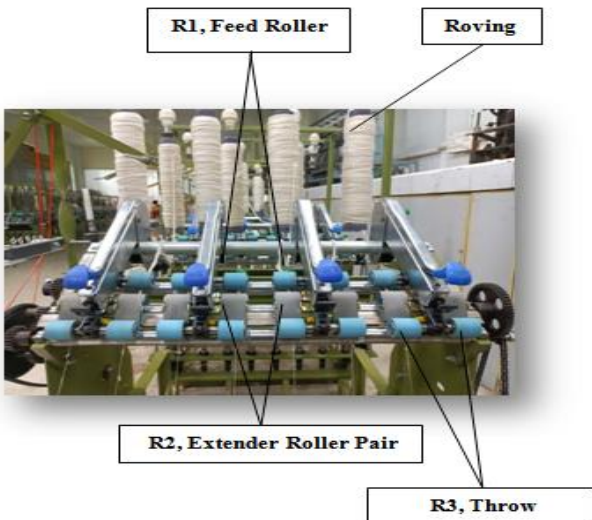

Fig.2 Feed Rollers

V. DESIGN AND CALCULATIONS OF MODIFIED NMC CHARKHA

1 For calculating actual power required to operate the charkha

Method 1: Weight adding method in pan
 2.8 kg force is required to operate the handle of charkha (with staple pressure)

Torque = Force * perpendicular dist. (length)

$$T = 2.8 * 9.81 * 0.2 \dots\dots\dots (\text{length of handle } 0.2\text{m})$$

$$T = 5.4 \text{ Nm}$$



$$\text{Power/strand} = p^2 \left[\frac{v}{104} - \frac{v^{1.41}}{526} \left[26 - 25 \cos\left(\frac{180}{T_1}\right) \right] \right] * kc$$

$$= 6.25^2 \left[\frac{0.1335}{104} - \frac{0.1335^{1.41}}{526} \left[26 - 25 \cos\left(\frac{180}{17}\right) \right] \right] * 1.7$$

(Kc= 1.7 Table XIV-1 DDB)

$$\text{Power/strand} = 0.0396 \text{ watt}$$

$$\text{No. of strand} = \frac{\text{Design Power}}{P/\text{strand}}$$

$$= \frac{53.83}{39.61}$$

$$= 1.35 \approx 2$$

$$\text{No. of strand} = 2$$

$$\begin{aligned} \text{Total Power} &= P/\text{strand} * \text{no. of strand} \\ &= 39.61 * 2 \end{aligned}$$

$$\text{Total power} = 79.22 \text{ watt}$$

As per condition

$$\begin{aligned} \text{To check, Total Power} &\geq \text{Design power} \\ 79.22 &\geq 53.83 \end{aligned}$$

Condition is satisfied and hence design is safe.

No of Teeth on larger sprocket & pitch dia

$$T_2 = T_1 * \frac{N_1}{N_2}$$

$$= \frac{17 * 75}{17} \dots\dots\dots(N_2 = 17 \text{ calibrated speed of cam shaft})$$

$$\boxed{T_2 = 75}$$

Condition: Max no. of teeth on larger sprocket 100-120 as per table XIV-3 DDB

T₂= 75 hence condition is satisfied

$$Do_2 = \text{Pitch} * \left[0.6 + \cot\left(\frac{180}{T_2}\right) \right]$$

$$= 6.25 * \left[0.6 + \cot\left(\frac{180}{75}\right) \right]$$

$$= \left[0.6 + \frac{1}{\tan(2.4)} \right]$$

Pitch diameter of larger sprocket

$$D_{p2} = \frac{\text{Pitch}}{\sin\left(\frac{180}{T_2}\right)}$$

$$= \frac{\text{Pitch}}{\sin\left(\frac{180}{75}\right)}$$

$$\boxed{D_{p2} = 149.25 \text{ mm}}$$

Max Permissible bore diameter.

If the sprocket is keyed to the given shaft check that max permissible box (table XIV-3 DDB) is larger than given shaft diameter

$$\begin{aligned} \text{Max permissible bore dia} &= \frac{d < (T_1 - 5)p}{4} \text{ for } p \leq 25.4 \\ &\dots\dots\dots(\text{table XIV-3 DDB}) \end{aligned}$$

$$= \frac{(17-5)*6.25}{4}$$

$$\text{Max permissible bore dia} = 18.75 \text{ mm}$$

From table XII-3, shaft dia for 38.45 rated power (watt) and 75 rpm is 9 mm dia which is less than max permissible bore of 18.75 mm

Hence design is ok

Outside dia of smaller sprocket Do₁

$$Do_1 = \text{Pitch} * \left[0.6 + \cot\left(\frac{180}{T_1}\right) \right] \dots\dots\dots(\text{Table XIV-4 DDB})$$

$$= 6.25 * \left[0.6 + \cot\left(\frac{180}{17}\right) \right]$$

$$= \left[0.6 + \frac{1}{\tan(10.58)} \right]$$

$$\boxed{Do_1 = 37.21 \text{ mm}}$$

Outside dia of larger sprocket Do₂

$$\boxed{Do_2 = 152.87}$$

Width of Sprocket

For single strand
 $t_o = 0.58 * \text{Pitch} - 0.15$ (Table XIV-4 DDB)
 $t_o = 0.58 * 6.25 - 0.15$

$$T_o = 3.4$$

Length of chain
 $\frac{T_1 + T_2}{2} + \frac{2c}{p} + \frac{p(T_1 - T_2)^2}{40c}$ (Table XIV-1 DDB)

$$\theta = 120^\circ \text{ i.e } 2.09 \text{ radian}$$

$$\theta = \pi - \frac{Dp_2 - Dp_1}{c}$$

$$120 = \pi - \frac{149.25 - 34.01}{c}$$

$$C = 109.58 \text{ mm}$$

But from the table XIV-3 the min centre distance is
 $C_{min} = \text{Diameter of larger sprocket} + \frac{1}{2} \text{ Diameter of smaller sprocket}$

$$C_{min} = 152.87 + \frac{1}{2} * 37.21$$

$$C_{min} = 171.47 \approx 172$$

$$\text{Length of chain in pitches} = \frac{17+75}{2} + \frac{2*172}{6.25} + \frac{6.25*(17-75)}{40*172}$$

$$\text{Length of chain in pitches} = 109.09 \text{ mm}$$

$$\text{Roller Dia. Of Chain} = \frac{5}{8} * \text{pitch}$$

$$d_r = \frac{5}{8} * 6.25$$

$$d_r = 3.9$$

$$H_p = 0.82 * p$$

$$H_p = 0.82 * 6.25$$

$$H_p = 5.125 \text{ mm}$$

Max height of roller link plate

$$H_r = 0.95 * p$$

$$H_r = 0.95 * 6.25$$

$$\text{Chain Width} = \frac{5}{8} * \text{pitch}$$

$$w = \frac{5}{8} * 6.25$$

$$W = 3.9 \text{ mm}$$

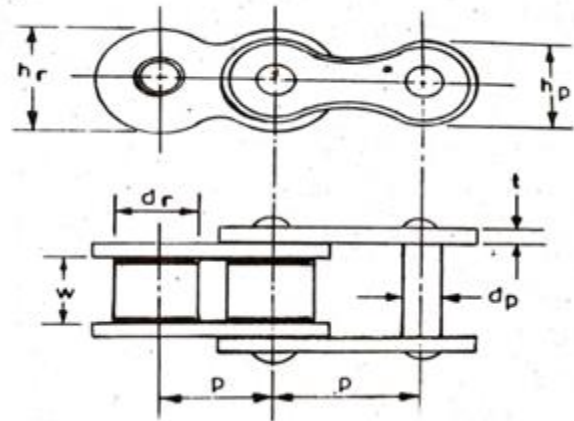

Fig.3: Chain linkages

Pin Diameter $d_p = \frac{5}{16} * \text{pitch}$ (table XIV-3 DDB)

$$= \frac{5}{16} * 6.25$$

$$d_p = 1.95 \text{ mm}$$

Thickness of link plate = $\frac{1}{8} * \text{pitch}$ (table XIV-3 DDB)

$$\text{Thickness of link plate} = 0.78 \text{ mm}$$

Max height of pin link plate

$$H_r = 5.9 \text{ mm}$$

3. Power is transmitted to cam shaft with the help of chain drive

$$\text{Speed of cam shaft} = T_1 * N_1 = T_2 * N_2$$

$$= 17 * 75 = 75 * N_2$$

$$N_2 = 17 \text{ rpm}$$



4. Power required for lifting the Ring rail

i.e Ring rail (movable plate) which moves up and down to guide a yarn for winding on bobbin ... (ref fig 1.2)

Work done = Force * velocity

(Weight of Ring rail (movable plate) = 700gm)

Work done = $0.7 * 9.81 * \frac{0.8}{6}$ (Dist covered 0.8m in 6 sec)

Work done/Power = 0.91 watt

Power required for cam to lift the movable plate is 0.91 watt

5. Power required/ speed of bobin

$I = \frac{MR^2}{2}$ (moment of inertia of a cylinder)

(Weight of bobin= 15gm, dia. of bobin= 0.015m)

$I = \frac{0.015 * 0.015^2}{2}$

$I = 1.68 * 10^{-6}$

RPM of bobin is 7000 rpm

$\omega = \frac{2\pi N}{60}$

$\omega = \frac{2\pi * 7000}{60}$

$\omega = 733.03$

$\alpha = \frac{dw}{dt}$

$= \frac{w_2 - w_1}{dt} = \frac{733.03 - 0}{2}$

$\alpha = 366.5 \text{ r/s}^2$

Torque = $I * \alpha$

$T = 1.68 * 10^{-6} * 366.5$

$T = 0.61 * 10^{-3}$

Power required for bobin rotating

Power = $\frac{2\pi N T}{60}$
 $= \frac{2\pi * 7000 * 0.61 * 10^{-3}}{60}$

Power = 0.447 watt (for one bobin)

Power required for 8 bobin to rotate = 3.576 watt

6. Package density of bobin

Empty bobin dia = 1.5cm

Full bobin dia = 2.0 cm

Transverse length H = 12 cm

Weight of yarn in the package = 25gm

Volume of Yarn in package = $(\pi r_1^2 h) - (\pi r_2^2 h)$
 $= (\pi 2.0^2 * 12) - (\pi 1.5^2 * 12)$

Volume of Yarn in package = 81.43 cm³

Package density = $\frac{\text{weight of yarn in the package}}{\text{volume of yarn in the package}}$

$= \frac{25}{81.43}$

Package density = 0.37 gm/cm ³

7.

By using same chain drive specifications power is transmitted from handle shaft to pulley shaft with the help of chain drive.

Power is transmitted in two stages of chain drive (ref fig 1.1) for reducing slippage of drive and for safe design.

To obtain the bobin speed of 7000 rpm & pulley shaft speed, proper sprocket teeth and pulley size has selected.

N1 (Speed of handle shaft) = 75 rpm

N2 (speed of free gear sprocket) = ?

T1 (Teeth of larger sprocket on handle shaft) = 60

T2 (Teeth of smaller sprocket on free gear shaft) = 18

$N_1 * T_1 = N_2 * T_2$

$75 * 60 = N_2 * 18$



$$N_2 = 250 \text{ rpm}$$

Speed of free gear is 250 rpm

N_3 (Speed of free gear) = 250 rpm

N_4 (Speed of pulley shaft) = 833 rpm

T_3 (Teeth of larger sprocket on free gear shaft) = 60

T_4 (Teeth of smaller sprocket on pulley shaft) = 18

$$N_3 * T_3 = N_4 * T_4$$

$$250 * 60 = N_4 * 18$$

$$N_4 = 833 \text{ rpm}$$

Speed of pulley shaft is 833 rpm

Speed of bobin is 7000 rpm

To select a Diameter of pulley for transmitting power to rotate the bobin

D_1 (Dia. Of pulley) =?

D_2 (Dia. Of bobin pulley) = 15mm

N_1 (Speed of pulley shaft) = 833 rpm

N_2 (speed of bobin) = 7000 rpm

$$N_1 * D_1 = N_2 * D_2$$

$$833 * D_1 = 7000 * 15$$

$$D_1 = 126.5 \text{ mm}$$

Dia of pulley is 126.5 mm \approx 127 mm or 5"

powered Lilliput gin", International Engineering Journal For Research & Development

- [4]. Haidar F. AL-Qrimli, Karam S. Khali, Ahmed M. Abdelrhman, Roaad K. Mohammed A & Husam M. Hadi "A Review on a Straight Bevel Gear Made from Composite".
- [5]. A. AthisayaSagayaRajan G. ShaikUsmansha "Optimization & Analysis of Forging Press Gear Box" March, 2014, Vol 3 Issue 3.
- [6]. M.S. Navle, Dr. A. V. Damale "Weight Optimization of the Gear Train – A Review" Vol. 3, Special Issue 1, March 2016.
- [7]. Andure M.W. , Jirapure S.C. , Dhamande L.P "Advance Automobile Material for Light Weight Future – A Review" , International Conference on Benchmarks in Engineering Science and Technology ICBEST 2012. [8] Prof. A.B. Tupkar, Mr.PrashikJiwane. "Design And Fabrication of Roving Making Machine, International Conference ISTE &IE September
- [8]. KHADI -Release of e – Charkha
- [9]. Report on Technology Transfer of Solar Charkha in Khadi Sector, Mr. Ravi Kandasamy¹, Mr. Deep Varma², Mr. Sachin Raut³, Mr. Ganesh There⁴, International Journal of Modern Engineering Research Vol. 3, and Issue. 4, Jul - Aug. 2013 pp-1965-1979 ISSN: 2249-664
- [10]. "Khadi & Village Industries Commission (KVIC)."
- [11]. "Assessment of factors affecting the productivity of amber charkha Ergonomics Evolution of workers." G. V. Thakre et al. / International Journal of Engineering Science and Technology (IJEST), ISSN: 0975- 5462, Vol. 3 No.11 November 2011 7871.
- [12]. Revival of Khadi – An Analysis of the State Of Khadi in India with Supply And Demand Side Problems Nitish Goel¹. Kshitij Jain² ¹Department of Chemical Engineering, Indian Institute of Technology Delhi, New Delhi, India 110016 Innovative Journal of Business and Management 4:5, September – October (2015) 100 – 103.

VI. REFERENCE

- [1]. Dr.G. V. Thakre , "Assessment of factors affecting the productivity of amber charkha Ergonomics Evolution of workers." et al. / International Journal of Engineering Science and Technology (IJEST), ISSN: 0975-5462, Vol. 3 No. 7871, 11 November 2011.
- [2]. R.Chattopadhyay, R.B.Chavan and R.K.Nayak , "NMC Charkha: A Design Analysis" from Technological Considerations Department of Textile Technology Indian Institute of Technology, New Delhi 110 016, India.
- [3]. N. U. Alone, Prof. J. F. Agrawal, "Experimental Validation of best suitable mechanisms for manually

IJEAST

INTERNATIONAL JOURNAL
OF ENGINEERING APPLIED SCIENCE
AND TECHNOLOGY

ABOUT IJEAST

International Journal of Engineering Applied Science and Technology (IJEAST) is a peer-reviewed, open access journal that publishes high-quality research papers in the field of Engineering, Applied Science and Technology.

IJEAST aims to provide a platform for researchers, academicians, and professionals to share their innovative ideas, research findings, and practical experiences with the global scientific community.

FOCUS AREAS

- Engineering
- Applied Science
- Technology
- Innovation & Development
- Interdisciplinary Studies



PEER REVIEWED

All submissions are rigorously peer reviewed to ensure quality.



OPEN ACCESS

Free and unrestricted access to research for all.



GLOBAL REACH

Connecting researchers and professionals worldwide.



TIMELY PUBLICATION

We ensure a swift and efficient publication process.



For more information, visit our website

www.ijeast.com



INTERNATIONAL JOURNAL
OF ENGINEERING APPLIED SCIENCE
AND TECHNOLOGY

✉ editor@ijeast.com

🌐 www.ijeast.com

📍 India



2455-2143