



IJEAST

INTERNATIONAL JOURNAL
OF ENGINEERING APPLIED SCIENCE
AND TECHNOLOGY



VOLUME : 2 ISSUE : 3 Print / Issue Publication Date: 29-Jan-2022



ISSN : 2455-2143



DOI : 10.33564/IJEAST.2021.v06i07.035

Indexed In



WWW.IJEAST.COM

editor@ijeast.com

STEP RESPONSE OF CONTROLLERS IN HVDC TRANSMISSION LINK CONNECTED TO A STRONG INVERTER SIDE AC SYSTEM

S. Seenivasan
Assistant Professor,
Department of EEE
Annamalai University,
Annamalai Nagar – 608 002

S. Vadivel
Assistant Professor,
Department of EEE
Annamalai University,
Annamalai Nagar – 608 002

Abstract— Transmission of electrical energy with High Voltage Direct Current (HVDC) has provided the electric power industry with a dominant means to transmit huge quantity of electricity over very long distances. To investigate the performance, a well-developed current source converter based HVDC transmission system model is projected, in which the AC system represented as damped LLR equivalent and is equipped with double tuned harmonic filter to mitigate the AC-DC harmonics and the DC system is secured with rectifier current control, inverter current control and inverter extinction angle control. The MATLAB/Simulink based simulation results validate the step response of HVDC transmission system with various controllers.

Keywords— HVDC transmission systems, Double tuned filter, Rectifier DC Current Control, Inverter DC Current-Extinction Angle Control, Step response.

I. INTRODUCTION

The power transmission through HVDC technology is now mature and experiencing rapid increases in the voltage, power carrying capacity and length of transmission lines. While comparing with three phase HVAC transmission systems, HVDC transmission system is commendable in the following portions: (i) HVDC transmission line cost and operating cost are less, (ii) it need not operate synchronously between two AC systems linked by HVDC and (iii) it is simple to control and adjust the power flow [1]. HVDC transmission system is composed of three major parts: a) rectifier station to convert AC to DC, b) transmission link and c) inverter station to convert back to AC. Most of the HVDC systems have line commutated converters. Various control techniques are employed for the control and protection of the line and converter against faults [2]. The thyristor based HVDC system naturally absorbs a large amount of reactive power in rectifier stations and inverter stations [3], [4]. By means of filters and/or capacitor banks connected on the primary side of the

converter transformer, the reactive power is supplied for HVDC links connected to strong AC systems [5] [6].

Because of the speedy increase in HVDC power transmission schemes, the behaviours of HVDC systems are playing ever greater roles in the performance of entire AC/DC power systems. It is significant to thoroughly understand the mechanisms of the interactions between an HVDC system and an AC network so the HVDC scheme can be operated in a manner that enhances the stability of the entire power grid. The significance of this interaction largely depends on the strength of the AC system at the converter bus [7]. The strength of the AC system is demonstrated by its ability to maintain the voltage at the converter bus during various disturbances in the power system, such as faults etc. Their influence on station design and performance is assessed with reference to the AC-DC system strength, which is generally expressed by the short-circuit ratio (SCR), i.e., the ratio of the AC-system short-circuit capacity to DC-link power: $SCR = S/P_{dc}$. Here S is the AC system three-phase symmetrical short-circuit level in megavolt-amperes (MVA) at the converter terminal AC bus with 1.0 p.u AC terminal voltage, and P_{dc} is the rated DC terminal power in megawatts (MW). The following SCR values can be used to classify AC systems [8]: a) a strong AC system is categorized by $SCR > 3$, b) a weak AC system is categorized by $2 \leq SCR < 3$, c) a very weak AC system is categorized by $SCR < 2$.

A lot of works has been done to know the interaction between ac systems and HVDC link when strong AC system is considered in both the rectifier and the inverter side. Earlier research in [9] investigates the steady state and dynamic performance of the system in MATLAB-Simulink environment by considering few cases of fault conditions. Analysis of dynamic operating characteristics of the HVDC in advanced digital power system simulator (ADPSS) is carried out in [10] but have not been discussed in detail. So, a well-developed detailed model of current source converter based monopolar HVDC transmission system is presented in this

paper. The rectifier side is equipped with DC current controller and inverter side is equipped with DC current-extinction angle control. The rectifier and inverter controllers are the simplest yet robust fixed gain PI type of controllers. The HVDC transmission system model is developed in the MATLAB-Simulink environment. The step response of the various DC side controllers has been validated by observing AC and DC quantities in rectifier and inverter sides.

The rest of the paper is organized as follows. Modelling of HVDC Transmission System is explained in section II. 3. HVDC MATLAB Simulation results are presented in section III. Concluding remarks are given in section IV.

II. MODELLING OF HVDC TRANSMISSION SYSTEM

A line commutated converter based monopolar HVDC transmission system of 500 kV, 2 kA (1000 MW) shown in the figure 1 is used for the model development.

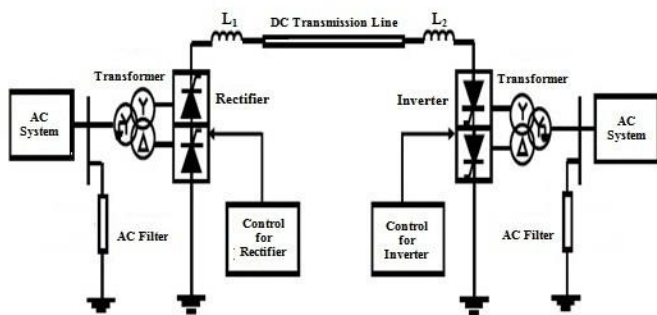

Fig 1. The monopolar HVDC transmission system model

A. The AC Network –

The rectifier side AC system of 500 kV, 5000 MVA, 60 Hz network (AC system 1, SCR of 5) to 345 kV and inverter side AC system of 5000 MVA, 50 Hz network (AC system 2, SCR of 5) are represented by damped LLR equivalents [11] with an angle of 80 degrees at fundamental frequency (60 Hz or 50 Hz) and at the third harmonic. This is likely to be more representative in the case of resonance at low frequencies. The Passive filters of 300MVAR is connected in the source side to eliminate the 11th and 13th (the double tuned type) [12] order and above 24th (second order high pass filter) order current harmonics and a capacitor (300MVAR) for reactive power compensation.

B. Converter transformer –

The 1200 MVA converter transformers (Wye grounded/Wye/Delta) are modelled with Three-Phase Transformer (Three-Winding) blocks. The parameters adopted (based on AC rated conditions) are considered as typical for transformers found in HVDC installation such as leakage: $X = 0.24$ per unit [13]. The transformer tap changers are not simulated. The tap position is quite at a set position

determined by a duplication factor applied to the primary nominal voltage of the converter transformers (0.90 on the rectifier side; 0.96 on the inverter side).

C. Converters –

The rectifier and the inverter are 12-pulse converters have been modelled using two Universal Bridge blocks [14] connected in series. The Universal Bridge blocks is a compact representation of a DC converter, which includes a built in 6-pulse Graetz converter bridge (can be inverter or rectifier) and Series RC snubber circuits are connected in parallel with each switch device.

D. DC network –

The DC network model consists of a smoothing reactor for the rectifier and the inverter bridges, a passive filter of double tuned type to mitigate the 12th and 24th order DC voltage harmonics [15] and the DC line. The DC link of 300 km is modelled as distributed parameter line model with lumped losses. In this model, the lossless distributed LC line is characterized by two values namely the surge impedance and the phase velocity.

E. HVDC Control and Protection –

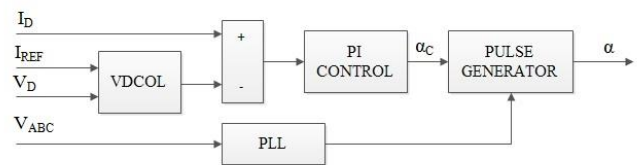

Fig 2. Logic diagram of the rectifier control system model.

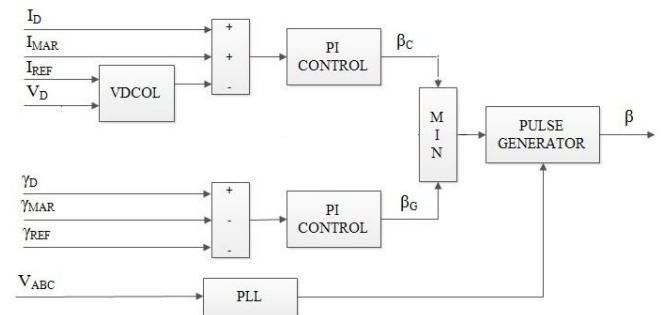

Fig 3. Logic diagram of the inverter control system model.

The rectifier is equipped with a current controller to maintain the DC system current constant. The DC system current at the rectifier end is measured with the proper transducers and pass through the appropriate filters. After filtering, the measured currents are compared to the reference currents to produce error signals. The error signal from converter side is then passed through the PI controller to produce firing angle order. The firing circuit which is synchronized with the AC system through phase locked loop uses the angle order, to produce the necessary equidistant pulses for the valves. The inverter is

provided with a current controller and a constant extinction angle controller to maintain the DC system current and extinction angle constant. The DC system current at the inverter end is measured with the proper transducers and pass through the appropriate filters. After filtering, the measured currents are compared to the reference currents to produce error signals. The error signal from converter side is then passed through the PI controller to produce firing angle order. Similarly, the DC system extinction angle at the inverter end is measured with the proper transducers and passes through the appropriate filters, the measured extinction angle are compared to the reference extinction angle to produce error signals. The error signal from converter side is then passed through the PI controller to produce firing angle order. These two firing angle orders are compared, and the minimum is used to produce the firing pulses for the valves [16].

The reference currents for the CC controllers are obtained from the master controller outputs through the voltage dependent current order limiter (VDCOL) [17] which can reduce the reference value of direct current (I_{dref}) in case of the large decline in direct voltage, to suppress the over-current and maintain the system voltage. In normal state, there is a small margin (I_{dmarg}) between the direct current references of the two constant-current controllers. Since $I_{dref-inverter}$ will be smaller than $I_{dref-rectifier}$, the output of the constant-current controller configured in the inverter side will be regulated to its maximum, and accordingly this controller will not be selected among the two controllers. Then, the inverter's firing angle will be dominated by the constant-voltage controller. To protect the rectifier and the inverter DC Protection functions are implemented in each converter. The DC fault protection circuit at the rectifier detects and force the delay angle into the inverter region to quench the fault current. The commutation failure prevention control circuit at the inverter detects various AC fault and reduce the utmost delay angle limit to decrease the risk of commutation failure [18]. The Low AC Voltage Detection circuit at the rectifier and inverter serves to categorize between an AC fault and a DC fault.

III. HVDC MATLAB SIMULATION

The HVDC transmission systems model is implemented in the working platform of MATLAB adapting above mentioned range of features based on the data in [19] with essential modifications. For step response analysis, the system has been simulated for duration of 2 sec. in MATLAB-Simulink environment.

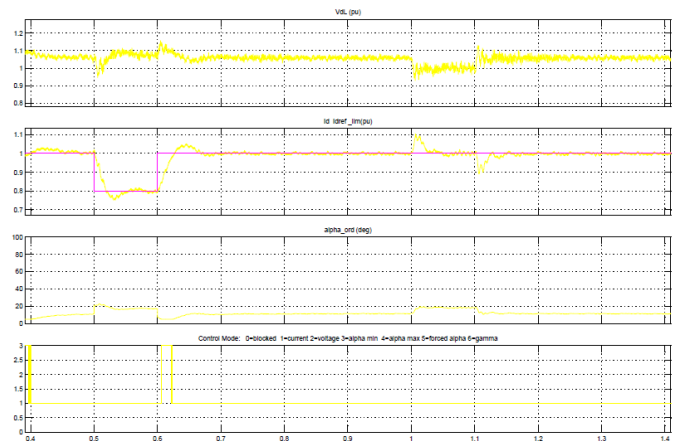

Fig 4. Rectifier DC quantities

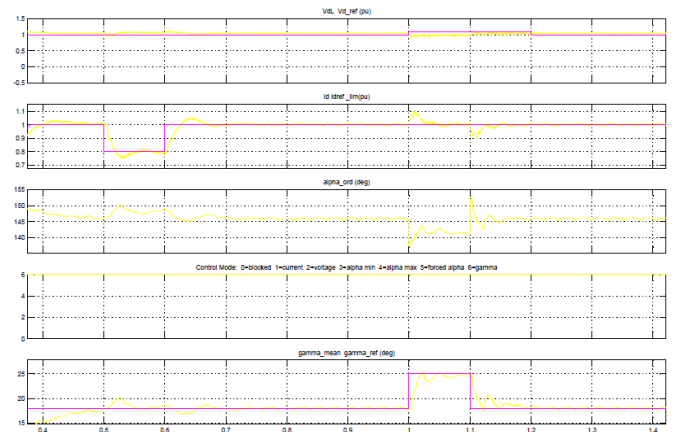

Fig 5. Inverter DC quantities

A. Step response of current regulators

In order to observe the step response of current regulators at both rectifier and inverter side, at $t = 0.5s$, a -0.2 p.u. step is applied for a duration of $0.1s$ to the reference current. The figures 4 and 5 shows the response of the current regulators in rectifier and inverter side respectively. The step change is effected in less than 100 ms, and the step response is well controlled and stable.

B. Step response of extinction angle regulator

In order to observe the dynamic response of voltage regulator at inverter side, at $t = 1s$, the extinction angle is raised from 18 to 23 degree for a duration of $0.1s$. The figures 4 and 5 also shows the response of the inverter voltage regulator in rectifier and inverter side respectively. The step change is effected in less than 200 ms, and the step response is well controlled and stable. As it clear that the extinction angle regulator plays a vital role in the control of inverter.



IV. CONCLUSION

The HVDC transmission system model is implemented in the Matlab/Simulink environment and the step response of the controllers in controlling the desired current and extinction angle for typical step change is investigated by observing the rectifier DC quantities and inverter DC quantities. Simulation results show that the step change is well controlled by the corresponding controllers.

V. REFERENCE

- [1] Kala Meah, Sadrul Ula, "Comparative Evaluation of HVDC and HVAC Transmission Systems", IEEE General Meeting on Power Engineering Society, pp.1-5, 2007.
- [2] Agelidis.V. G, Demetriades.G. D, Flourentzou.N, "Recent Advances in High-Voltage Direct-Current Power Transmission Systems", IEEE International Conference on Industrial Technology (ICIT), pp.206-213, 2006.
- [3] N. G. Hingorani., Laszlo Gyugyi, "Understanding FACTS: Concept and Technology of Flexible AC Transmission Systems", New York, 1999
- [4] T.J.Miller, "Reactive Power Control in Electric Systems", John Wiley & Sons, 1982.
- [5] M. Khatir, S A. Zidi, S. Hadjeri, M K. Fellah, R. Amiri, "Performance Evaluation of Line and Capacitor Commutated Converter based HVDC System in Simulink Environment", Journal of Electrical & Electronics Engineering, Vol. 8, No. 8, pp.481-490, 2008.
- [6] M.O.Farque, Yuyan Zhang, Venkata Dinavahi, "Detailed Modeling of CIGRE HVDC Benchmark System using PSCAD / EMTDC and PSB/SIMULINK", IEEE Transactions on Power Delivery, 2006.
- [7] S.Rao, "EHV-AC, HVDC Transmission and Distribution Engineering", Khanna publishers, New Delhi, India, 2003.
- [8] Gavrilovic, "AC/DC System Strength as Indicated by Short Circuit Ratios", AC/DC Conference, 1991.
- [9] Sid Ahmed Zidi, Samir Hadjeri, M. Karim Fellah, "The performance analysis of an HVDC link", Electronic Journal, Technical Acoustics, 2004.
- [10] Lei Chen, Kan-Jun Zhang, Yong-Jun Xia, and Gang Hu, "Hybrid Simulation of ± 500 kV HVDC Power Transmission Project Based on Advanced Digital Power System Simulator", Journal of Electronic Science and Technology, Vol. 11, No. 1, 2013.
- [11] Zidi. S. A, Hadjeri. S, Fellah. M. K, "Dynamic Performance of an HVDC Link, Journal of Electrical Systems", No. 1-3, pp. 5-23, 2005.
- [12] XiaoYao, "Algorithm for Parameters of Double Tuned Filter", IEEE Conference on Harmonic and Quality of Power (PEcon), Greece, Vol. 1, pp. 154-157, 1998.
- [13] G.Bhuvaneswari, B.C. Mahanta, "Analysis of Converter Transformer Failure in HVDC Systems and Possible Solutions", IEEE Transactions on Power Delivery, Vol. 24, No. 2, pp. 814-821, 2009.
- [14] Rajiv Kumar, Thomas Leibfried, "Analytical Modelling of HVDC Transmission System Converter using Matlab/Simulink", IEEE Technical conference on Industrial and Commercial Power Systems Saratoga Springs, New York, pp. 140-146, 2005.
- [15] J. Arrillaga, N.R. Watson, "Power System Harmonics", John Wiley & Sons Ltd, West Sussex, England, 2003.
- [16] Szechtman.M, Wess.T, Thio.C.V, "A Benchmark Model for HVDC System Studies", IEEE International Conference on AC and DC Power Transmission, pp.374-378, 1991.
- [17] P.Kundur, "Power System Stability and Control", TATA McGraw-Hill Publishing Company Limited, New Delhi, 1993.
- [18] Lidong Zhang, Lars Dofnas, "A Novel Method to Mitigate Commutation Failures in HVDC Systems", Proceedings International Conference-Power Con, Vol. 1, pp. 51-56, 2002.
- [19] Christian Dufour, Jean Mahseredjian, Jean Belanger, "A Combined State-Space Nodal Method for the Simulation of Power System Transients", IEEE Transactions on Power Delivery, Vol. 26, No. 2, pp. 928-935, 2011.

IJEAST

INTERNATIONAL JOURNAL
OF ENGINEERING APPLIED SCIENCE
AND TECHNOLOGY

ABOUT IJEAST

International Journal of Engineering Applied Science and Technology (IJEAST) is a peer-reviewed, open access journal that publishes high-quality research papers in the field of Engineering, Applied Science and Technology.

IJEAST aims to provide a platform for researchers, academicians, and professionals to share their innovative ideas, research findings, and practical experiences with the global scientific community.

FOCUS AREAS

- Engineering
- Applied Science
- Technology
- Innovation & Development
- Interdisciplinary Studies



PEER REVIEWED

All submissions are rigorously peer reviewed to ensure quality.



OPEN ACCESS

Free and unrestricted access to research for all.



GLOBAL REACH

Connecting researchers and professionals worldwide.



TIMELY PUBLICATION

We ensure a swift and efficient publication process.



For more information, visit our website
www.ijeast.com



INTERNATIONAL JOURNAL
OF ENGINEERING APPLIED SCIENCE
AND TECHNOLOGY

✉ editor@ijeast.com

🌐 www.ijeast.com

📍 India



2455-2143