



IJEAST

INTERNATIONAL JOURNAL
OF ENGINEERING APPLIED SCIENCE
AND TECHNOLOGY



VOLUME : 5 ISSUE : 3 Print / Issue Publication Date: 15-Sep-2020



ISSN : 2455-2143



DOI : 10.33564/IJEAST.2020.v05i03.003

Indexed In



WWW.IJEAST.COM

editor@ijeast.com



THE INFLUENCE OF EFFORT EXPECTANCY AND COGNITIVE NEED ON INTENTION TO ADOPT DISTANCE LEARNING

May Ahmed Alshahri
Department of Information Systems,
College of Commerce and Business Administration, City-Salalah

Abstract—This research aimed to investigate the effect of effort expectancy and cognitive needs on the students' intention to adopt distance learning. In this study, the quantitative research approach was employed. Data were collected from students of higher education institutions, and the total valid questionnaires suitable for analysis was 92. Many statistical tests including confirmatory, and structural equation modelling have been adopted in this paper and data was analyzed using AMOS 20 software. The findings show that both effort expectancy and cognitive needs have a significant effect on the students' intention to adopt distance learning. Hence, before implementing distance learning students should go through awareness programs that explain in details step by step how to use this technology and its related applications.

Keywords— Effort Expectancy, Cognitive Needs, Distance Learning.

I. INTRODUCTION

The transformations appeared in the late twentieth century which focus on the technological side, which has a major influence on the formation of society. Also, the number of IT users multiplied several times this makes it a research area from different perspective especially it terms of digitalization (Alraja, Hussein, and Ahmed 2021). This big transformation led to focus on information and its development and its exchange to build various knowledge through the use of information and communication technology, in order to form a new society that relies on knowledge in all its sectors. This technology has contributed to support e-learning or the distance learning and has become one of its applications (Al-Adwan, Al-Adwan, and Smedley 2013).

Distance education is a virtual learning environment based on taking advantage of modern technological means to dispense with the methods used in traditional learning (Chan et al. 2015; Uddin, Ahmar, and Alraja 2016). On the other hand, this type of university education helps to achieve the democracy of education, as it transmits education to every citizen wherever he wants and where he wants, and on the

other hand, it contributes to making education a continuous and extended process throughout life.

The issue of distance education has been addressed in many studies, where most of these studies (El-Masri and Tarhini 2017; Kim-Soon et al. 2015) have proven that this type of education faces many material and non-material challenges to achieve a successful learning environment as well as privacy and security issues (Alraja, Farooque, and Khashab 2019). And since the learner is one of the most important episodes of the educational process, research into the factors that stimulate or encourage the adoption of distance education is very important. It has been found through many studies that "effort expectation" (El-Masri and Tarhini 2017; Fianu et al. 2018) and "cognitive need" are key factors in influencing the learner's intention to adopt distance learning (Thongsri et al. 2018).

The present study will provide a theoretical framework describing both of "effort expectation" and "cognitive need" variables and measuring the relationship between them and the intention of learners to adopt distance learning.

II. LITERATURE REVIEW

Effort Expectancy (EE): It is simplicity level related with consumers' usage of technology (Alraja et al. 2016; Venkatesh, Thong, and Xu 2012) also it is the level of comfort associated with information systems usage (Venkatesh et al. 2003). Many previous studies have illustrated that effort expectancy has a positive effective on how he or she intends to use a system (Alraja 2015; Samsudeen and Mohamed 2019). The use and acceptance of learning management systems (LMS) have been investigated within higher-education systems, the findings revealed that the Effort Expectancy had a positive impact on the provision teachers' approaches (Radovan and Kristl 2017). Moreover, UTAUT theory were used to inspect a working model for learning outcomes. The results showed that the Effort Expectancy contributed in predicting both behavioral intention and in adopting the distance learning among higher-education (Chan et al. 2015). Further, UTAUT theory used to determine factors affecting students' intention to use mobile learning. The findings confirmed that "effort expectancy" have no relationship with the intention to adopt learning with mobiles (Kim-Soon et al.



2015). Another study examined the dimensions influenced “Massive Open Online Courses” (MOOC) implementing and usage. It was proved that effort expectancy has not a significant effect on the intention of use of MOOC system (Fianu et al. 2018). This study is presuming that in case that the students realizes the easiness of adopting and using distance learning system, it is more probably to shift to this new system. For this reason, the study suggested the following hypothesis:

H1- There is a positive significant effect of effort expectancy on students’ intention to adopt distance learning.

Cognitive Need (CN): It is identified as is the encouragement of students to utizied things in the same way of creative thinkers do it. Students are assumed to be confronted to blend their information of their education to solve their daily obstacles. In addition to that they should improve their skills to develop recent knowledge to solve problems, and to share their knowledge. Thus, to achieve the constructing knowledge demand, should be a tool (for instance an m-learning application) capable to motivate learners to increase their knowledge that are related to Integrating teaching practices (Thongsri et al. 2018). In this study students who are encouraged by information systems to explore for information if they perceive it as useful, they are more likely to use it more regularly.

H2- There is a positive significant effect of cognitive needs on students’ intention to adopt distance learning.

Base on the above-mentioned literature and suggested hypotheses the following (figure 1) model is proposed:



Figure 1: Study Model

III. RESEARCH METHODS

An online questionnaire distributed to collect the primary data about the study variables (Effort Expectancy, Cognitive Need). However, this tool has been prepared based on previously validated instruments (ALraja and Chikhi 2015; Thongsri et al. 2018; Venkatesh et al. 2012). The privacy of the respondents has been confirmed. Moreover, the responses were collected based on the five-point Likert scale. The questionnaire was distributed to the students of Universities

and colleges; only 92 questionnaires were valid questionnaires for analysis. Further, all the proper statistical investigations for confirming the validity and reliability of the instrument has been run. The results of those statistical analyses appear in the table (1), which ensure the internal consistency of construct and measures validity. As well as, to test the study hypothesis the structural equation modelling was adopted.

IV. RESULTS AND ANALYSIS

The values of statistical test Cronbach’s alpha as seen in table (1) all the constructs reached the acceptable level (0.70) (Hussein, Ahmed, and Alraja 2017; Wamba et al. 2017). Further, Skewness and Kurtosis statistics tests has been used to check the normal distribution, the results were within the acceptable rang +2 and -2. Further, all the loadings of the variables’ items were above the threshold 0.40(Alraja 2016; ALraja and Chikhi 2015; Alraja and Malkawi 2015; Malkawi, Alraja, and Alkhayer 2010).

Table -1 Instrument Validity

Constructs	Items	Mean	Std. D	Skew	Kurtosis	α	*Factor loadings
Effort Expectancy (EE)	EE1	3.58	0.88	-0.19	-0.79	0.84	0.87
	EE2						0.85
	EE3						0.74
Cognitive Needs (CN)	CN1	3.37	0.80	-0.37	0.87	0.73	0.54
	CN2						0.48
	CN3						0.87
Intention to adopt distance learning (Int)	Int1	3.5	0.89	-0.36	0.09	0.75	0.77
	Int2						0.66
	Int3						0.61

*Principal Component Analysis with Varimax rotation

Moreover, to check wither the collected data is suitable for Exploratory Factor Analysis (EFA), the statistical test Kaiser-Meyer-Oklin (KMO) was performed. Table 2 present the result of the mentioned test however the value for the dataset was above 0.60 and Bartlett’s test of Sphericity had a p-value of < 0.001(Alraja et al. 2019).

Table -2 Kaiser-Meyer-Oklin (KMO)

Kaiser-Meyer-Olkin Measure of Sampling Adequacy.		0.837
Bartlett's Test of Sphericity	Approx. Chi-Square	396.008
	df	36
	Sig.	0.000

Furthermore, as appear in table (3) the extracted factor with the highest initial eigen value was 37.585 % which is less than 50 % (Alraja et al. 2020). This indicate no common method biases were detected in this research.

Table -3 CMV

Component	Initial Eigen values			Extraction Sums of Squared Loadings		
	Total	% of Variance	Cumulative %	Total	% of Variance	Cumulative %



1	4.695	42.167	37.585	4.695	42.167	42.167
2						
8						
9	.199	2.21	100.000			

Note: Extraction Method: Principal Component Analysis

The fit indices for confirmatory factor analysis shown in table (4) were in the acceptable level (Alraja et al. 2019).

Table -4 CFA Fit Indices

fit indices	X2/df	GFI	CFI	RMR	RMSEA
Recommended	2 < X2/df < 5	> 0.90	> 0.90	0.08	0.08
Measured	2.72	0.905	0.901	0.07	0.08

Moreover, table (5) display the Standardized Factor Loadings all the assigned values were exceeded the acceptable level 0.50. More, the composite reliability prove the convergent validity, all constructs were got more than 0.70 (Alkhaldi et al. 2017).

Table -5 CFA Results

Constructs	Items	Standardized Factor Loadings (St. FL > .50)	CR > .60
Effort Expectancy (EE)	EE1	0.82	0.84
	EE2	0.80	
	EE3	0.78	
Cognitive Needs (CN)	CN1	0.77	0.73
	CN2	0.66	
	CN3	0.62	
Intention to adopt distance learning (Int)	Int1	0.76	0.79
	Int2	0.85	
	Int3	0.61	

To test the research proposed hypothesis Structural Equation Modelling (SEM) was adopted as it shown in Figure (2).

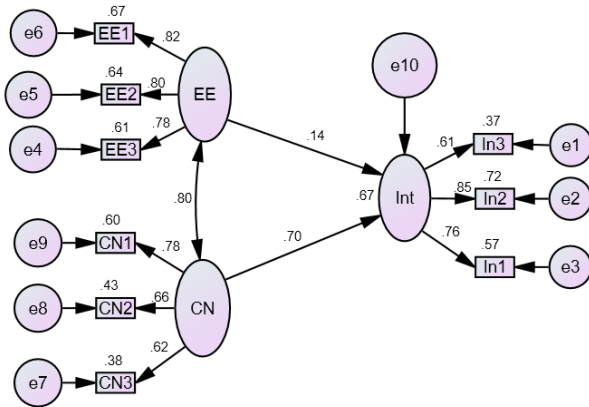

Figure 2. Tested model

As shown in Figure (2) the fit indices for the tested model show good fit as they are within their recommended values. The results show that effort expectancy and cognitive needs positively influences the students' intention to adopt distance learning. The weights of standard regression were 0.14

($p=0.00$), and 0.70 ($p=0.00$) respectively, explaining 67% of variance in the intention to adopt distance learning. Table 6 displays the results of hypothesis test which will be discussed in detail in the following section.

Table -6 SEM results

Hypotheses	Path	Standard Regression Weights (SRW)	Supported
H1- there is a positive significant effect of effort expectancy on students intention to adopt distance learning.	EE→Int	0.14	yes
H2- there is a positive significant effect of cognitive needs on students intention to adopt distance learning.	CN→Int	0.70	yes

V. DISCUSSION

The aim of this study was to identify the effect of effort expectancy and cognitive needs on the students' intention to adopt distance learning. In this regard the findings suggest that:

Effort Expectancy have a positive effect in encouraging students to adopt distance learning. This finding presents the importance of the required skills and efforts from the students to conduct the distance learning. This result comes in agreement with the results of (Alraja 2015; Kim-Soon et al. 2015; Samsudeen and Mohamed 2019) Who proved that effort expectancy have an important in supporting students to adopt distance learning. While this result was in contrary with (Fianu et al. 2018; Kim-Soon et al. 2015) who found that effort expectancy has no effect on adopting e-learning method by students.

Cognitive needs have a positive effect in encouraging students to adopt distance learning. Thereby, students think they will adopt distance learning if they perceive it's useful, they are more likely to use it. This result comes in agreement with the results of (Thongsri et al. 2018) Who found that cognitive needs are important in explaining students' intention to adopt distance learning. Hence, before implementing distance learning students should go through awareness programs that explain in details step by step how to use this technology and its related applications.



VI. CONCLUSION

The study aimed to investigate the effect of effort expectancy and cognitive needs on the students' intention to adopt distance learning. The study found that both effort expectancy and cognitive needs have a significant effect on the students' intention to adopt distance learning.

However, as all other research this study has its own limitation. The sample size was the main limitation thereby the results generation, as current situation (Covid-19 spread) researcher was not able to reach a significant number of students. Therefore, future research to include more respondents to solve this problem. In addition, study other factors to find out what are main factors that affect the students' intention to adopt distance learning.

VII. REFERENCE

- [1] Al-Adwan, Amer, Ahmad Al-Adwan, and Jo Smedley. 2013. "Exploring Students Acceptance of E-Learning Using Technology Acceptance Model in Jordanian Universities." *International Journal of Education and Development Using Information and Communication Technology (IJEDICT)* 9(2):4-18.
- [2] Alkhalidi, Firas M., Samir M. Hammami, Saleh Kasem, Abdullah Rashed, and Mansour Naser Alraja. 2017. "Enterprise System as Business Intelligence and Knowledge Capabilities for Enhancing Applications and Practices of IT Governance." *International Journal of Organizational and Collective Intelligence (IJOICI)* 7(2):63-77.
- [3] Alraja, M. N., and B. Chikhi. 2015. "Perceived Factors Affecting Customers Attitudes toward Electronic Shopping: An Empirical Study." *International Journal of Economic Research* 12(3).
- [4] Alraja, M. N., S. Hammami, B. Chikhi, and S. Fekir. 2016. "The Influence of Effort and Performance Expectancy on Employees to Adopt E-Government: Evidence from Oman." *International Review of Management and Marketing* 6(4).
- [5] Alraja, M. N., and Nazem M. M. Malkawi. 2015. "E-Business Adoption in Banking Sector: Empirical Study." *Indian Journal of Science and Technology* 8(27).
- [6] Alraja, Mansour Naser. 2015. "User Acceptance of Information Technology: A Field Study of an E-Mail System Adoption from the Individual Students' Perspective." *Mediterranean Journal of Social Sciences* 6(6 s1):19-25.
- [7] Alraja, Mansour Naser. 2016. "The Effect of Social Influence and Facilitating Conditions on E-Government Acceptance from the Individual Employees' Perspective | Efekt Wpływu Społecznego Oraz Warunków Ułatwiających Akceptację E-Administracji Z Punktu Widzenia Indywidualnych Pracowników." *Polish Journal of Management Studies* 14(2).
- [8] Alraja, Mansour Naser, Murtaza Mohiuddin Junaid Farooque, and Basel Khashab. 2019. "The Effect of Security, Privacy, Familiarity, and Trust on Users' Attitudes Toward the Use of the IoT-Based Healthcare: The Mediation Role of Risk Perception." *IEEE Access* 7:111341-54.
- [9] Alraja, Mansour Naser, Muawya Ahmed Hussein, and Hanaa Mahmoud Sid Ahmed. 2021. "What Affects Digitalization Process in Developing Economies? An Evidence from SMEs Sector in Oman." *Bulletin of Electrical Engineering and Informatics* 10(1).
- [10] Alraja, Mansour Naser, Sarfraz Fayaz Khan, Basel Khashab, and Raghad Aldaas. 2020. "Does Facebook Commerce Enhance SMEs Performance? A Structural Equation Analysis of Omani SMEs." *SAGE Open* 10(1):215824401990018.
- [11] Chan, Kevin, George Cheung, Kelvin Wan, Ian Brown, and Green Luk. 2015. "Synthesizing Technology Adoption and Learners Approaches Towards Active Learning in Higher Education." *The Electronic Journal of E-Learning* 13(6):442-51.
- [12] El-Masri, Mazen, and Ali Tarhini. 2017. "Factors Affecting the Adoption of E-Learning Systems in Qatar and USA: Extending the Unified Theory of Acceptance and Use of Technology 2 (UTAUT2)." *Educational Technology Research and Development* 1-21.
- [13] Fianu, Eli, Craig Blewett, George Oppong Appiagyeyi Ampong, and Kwame Simpe Ofori. 2018. "Factors Affecting MOOC Usage by Students in Selected Ghanaian Universities." *Education Sciences* 8(2).
- [14] Hussein, Muawya Ahmed, Hanaa Mahmoud Sid Ahmed, and Mansour Naser Alraja. 2017. "The Adoption of Information and Communication Technology by Small and Medium Enterprises in Oman: Case of Dhofar Region." *Journal of Business and Retail Management Research (JBRMR)* 11(3):64-71.
- [15] Kim-Soon, Ng, Mohamud Gaani, Abd Rahman Ahmad, and Ng Mei Xin Sirisa. 2015. "Factors Influencing Intention to Use Mobile Technologies for Learning among Technical Universities Students." in *The 26th International Business Information Management Association*. Madrid, Spain.
- [16] Malkawi, Nazem M. M. Al-ahmad, Mansour Naser Alraja, and Tarek Alkhayer. 2010. "Information Systems Auditing Applied Study at Banks Listed in the Damascus Stock Exchange Syria." *European Journal of Economics, Finance & Administrative Sciences* (21):119.
- [17] Radovan, Marko, and Nina Kristl. 2017. "Acceptance of Technology and Its Impact on Teacher's Activities in Virtual Classroom: Integrating UTAUT and CoI into a



- Combined Model.” TOJET: The Turkish Online Journal of Educational Technology 16(3).
- [18] Samsudeen, Sabraz Nawaz, and Rusith Mohamed. 2019. “University Students’ Intention to Use e-Learning Systems: A Study of Higher Educational Institutions in Sri Lanka.” *Interactive Technology and Smart Education* 16(3):219–38.
- [19] Thongsri, Nattaporn, Liang Shen, Yukun Bao, and Ibraheem Mubarak Alharbi. 2018. “Integrating UTAUT and UGT to Explain Behavioural Intention to Use M-Learning: A Developing Country’s Perspective.” *Journal of Systems and Information Technology* 20(3):278–97.
- [20] Uddin, M. A., F. Ahmar, and M. N. Alraja. 2016. “E-Examinations for Management Students in Oman.” *International Journal of Applied Business and Economic Research* 14(1).
- [21] Venkatesh, Morris, Davis, and Davis. 2003. “User Acceptance of Information Technology: Toward a Unified View.” *MIS Quarterly* 27(3):425.
- [22] Venkatesh, Viswanath, James Y. L. Thong, and Xin Xu. 2012. “Consumer Acceptance and Use of Information Technology: Extending the Unified Theory of Acceptance and Use of Technology.” *MIS Quarterly: Management Information Systems* 36(1):157–78.
- [23] Wamba, Samuel Fosso, Angappa Gunasekaran, Shahriar Akter, Steven Ji-fan Ren, Rameshwar Dubey, and Stephen J. Childe. 2017. “Big Data Analytics and Firm Performance: Effects of Dynamic Capabilities.” *Journal of Business Research* 70:356–65.

IJEAST

INTERNATIONAL JOURNAL
OF ENGINEERING APPLIED SCIENCE
AND TECHNOLOGY

ABOUT IJEAST

International Journal of Engineering Applied Science and Technology (IJEAST) is a peer-reviewed, open access journal that publishes high-quality research papers in the field of Engineering, Applied Science and Technology.

IJEAST aims to provide a platform for researchers, academicians, and professionals to share their innovative ideas, research findings, and practical experiences with the global scientific community.

FOCUS AREAS

- Engineering
- Applied Science
- Technology
- Innovation & Development
- Interdisciplinary Studies



PEER REVIEWED

All submissions are rigorously peer reviewed to ensure quality.



OPEN ACCESS

Free and unrestricted access to research for all.



GLOBAL REACH

Connecting researchers and professionals worldwide.



TIMELY PUBLICATION

We ensure a swift and efficient publication process.



For more information, visit our website

www.ijeast.com



INTERNATIONAL JOURNAL
OF ENGINEERING APPLIED SCIENCE
AND TECHNOLOGY

✉ editor@ijeast.com

🌐 www.ijeast.com

📍 India



2455-2143