



IJEAST

INTERNATIONAL JOURNAL
OF ENGINEERING APPLIED SCIENCE
AND TECHNOLOGY



VOLUME : 7 ISSUE : 08 Print / Issue Publication Date: 10-Feb-2023



ISSN : 2455-2143



DOI : 10.33564/IJEAST.2022.v07i08.017

Indexed In



WWW.IJEAST.COM

editor@ijeast.com



FAULT ANALYSIS OF INDUCTION MOTOR USING LABVIEW

N.Mekala

Department of EEE
Dhirajlal Gandhi College of Technology, Salem,
Tamilnadu, India

T.Jayabharathi

Department of EEE
Dhirajlal Gandhi College of Technology, Salem,
Tamilnadu, India

T.Rajkumar

Department of EEE
The Kavery Engineering College, Salem,
Tamilnadu, India

M.Priya darshini

Department of EEE
The Kavery Engineering College, Salem,
Tamilnadu, India

Abstract— In recent days induction motors are commonly used an industrial application due to the simple construction and robust cost. In this work three phase induction motor is used for monitoring the mechanical faults under various load conditions. The mechanical fault includes the bearing faults; there are two kinds of fault conditions are monitored with healthy and faulty bearing at different load conditions. The Lab VIEW and DAC system is used for monitoring the real time signals like line current and vibrations present in the healthy and faulty bearing conditions at different frequency levels of 3-phase induction motor drive system. In this experimental setup IGBT based PWM inverter drive system is connected to 3-phase induction motor. The various experimental results are verified with 5Hz and 25Hz.

Keywords— 3-phase Induction Motor, Mechanical Fault, Line Current, Lab VIEW, Real Time Monitoring.

I. INTRODUCTION

The induction motor is one of the most important motors, it is used in various industrial applications. It is used to convert electrical energy into mechanical energy, low cost and high performance in addition to its reliability make them the most popular alternating current motors are used in the industrial and commercial sectors. This motors have the flexibility of

application fields, they can be used in low power applications such as home appliances or in large power applications such as fuel industry[2]. In spite the fact of high reliability of induction motors the operating conditions may description the machine into different fault conditions. These faults may lead to machine shut down, thus causing industrial production losses.

The stator of an induction motor consists of polar carrying supply current to induce a magnetic field. It most commonly run on single phase or three phase power also, it can have any number of phases. Single phase motor needs some mechanism to produce rotating field on startup, single phase motors are increasingly used with VFDs. Its offer especially important energy saving method for induction motor but squirrel cage induction motor are widely used in both fixed speed and variable frequency drive applications.

Induction motor is one of the most important motors used in various industrial applications. The operating conditions are sometime lead the machine into different conditions. The main types of external faults are overloading, single phasing, unbalanced supply voltage and locked rotor, phase reversal, ground fault under voltage and over voltage, some time intervals faults also occurs like rotor bearing faults in [3].

The experimental results shows that three phase current envelop is powerful feature for motor faults classifications,

induction motor as healthy or faulty but also identifies the several of fault through the identification of the number of broken rotor bars or the number of short circuit turn in stator windings.

This paper presents the real time monitoring in fault analysis of induction motor at different load conditions and various speed changes of the induction drive. This paper real time signals are monitoring by using lab VIEW software, they are various signals to be discussed with motor healthy and fault conditions. This paper is considered brief about introduction in section 1 and Lab VIEW is discussed in section 2. Section 3 discussed the induction motor drive. Section 4 discussed the Experimental setup and section 5 described experimental results and concluding comments in section 6.

II. LABVIEW

The initiation of an idea to the commercialize of a widget, NI's single platform based advance to engineering and science applications has driven steps forward across a wide variety of company and industry. Laboratory Virtual Instrument Engineering Workbench (Lab VIEW) is a development of user friendly to designed specifically to accelerate the efficiency of engineers and scientists with a graphical programming syntax that make it simple to crete, visualize and code engineering systems, Lab VIEW is complete in helping you reducing test times, deliver business insights based on translate idea and collected data into reality. It is intended to interoperate with other software, whether different development approaches or open-source platforms, with an included software service program that provide phone and email support from degreed engineers, updates to the latest versions, and 23/7 access to online training and purchase of Lab VIEW software.

Lab VIEW is an integrated development environment designed specifically for engineers and scientists building measurement and control systems with a native graphical programming language, built-in IP for data analysis and signal processing and an open architecture that enables integration of any hardware device and any software approach, Lab VIEW is the software you need to construct the optimal solution that can meet your custom supplies and solve the challenges at hand. Lab VIEW 2016 software provides you the tools to focus on the problem you need to solve, with new features to simplify your development and also the channel wires and the latest innovation in data communication.

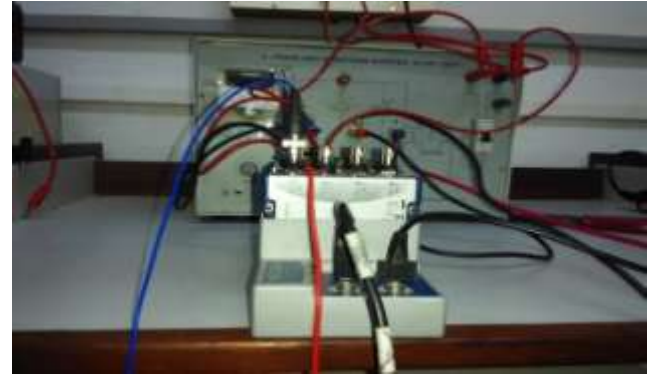

Fig 2.1 cDAQ with induction motor drive

The National Instrument was built with Lab VIEW. The National Instruments (NI) is used for both controlling and monitoring purpose. The data acquisition card and acquisition board were used in this paper to accure the line current and vibration signals for different load conditions. The current signal measurements are performed for a healthy and faulty conditions and test were carried out for different load conditions. The acquastic sensor is used to measure the vibration signals at different load conditions. Figure 2.1 shows the cDAQ with induction motor drive.

III. INDUCTION MOTOR

The universal adoption of ac system of distribution of electric energy for light and power field of application of ac motors have widened during recent years, various type of ac motors suitable for all classes of industrial drives for both single phase and three phase ac supply. In common dc motors the electric power is conducted directly to the armature through brushes and commutator but in ac motors the rotor does not receive electric power by conduction but induction is more are less the same way as the secondary of a winding transform receives its power from the primary also induction motor treated as a rotating transformer. Mostly its cannot unbreakable and also requires minimum maintenance. The three phase induction motor is shown in Figure 3.1



Fig 3.1 Induction motor

Short turn faults, bearing faults, rotor faults, gear faults are common faults of induction motor. Its classify into two types
 Electrical faults
 Mechanical faults

A mechanical fault includes bearing faults, load faults and misalignment faults and an electrical fault includes winding installation faults and some of the rotor faults.

IV. EXPERIMENTAL SETUP

The three phase induction motor used in this study has star connection, 3.6 A of rated current, the input voltage is 230V and 3000 rpm rotation capacity. In this experimental setup the real time monitoring and control of the parameters of induction motor are described.

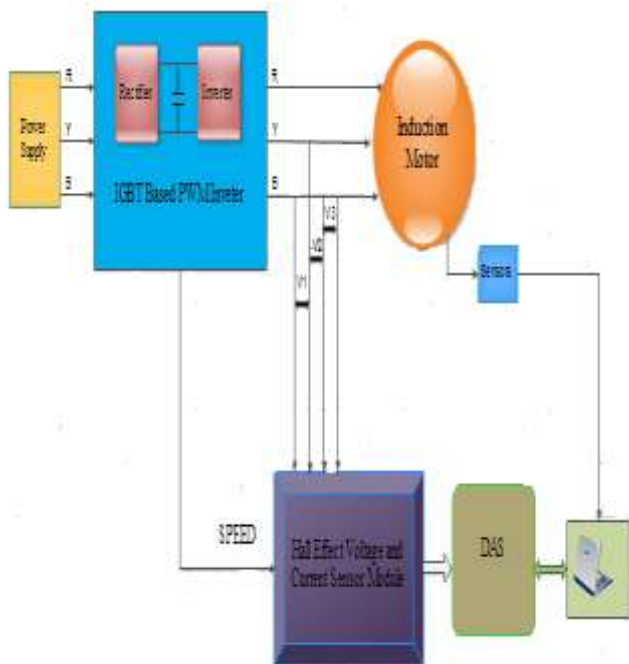

Fig 4.1 Block diagram of hardware Setup

This experimental study uses the induction motor faults and data collected from a data acquisition system with the help of Lab VIEW software. Figure 4.1 shows the black diagram of hardware setup.

V. HARDWARE RESULTS AND ANALYSIS

The experimental setup is based on three-phase induction motor is connected to a 230V supply. The experimental investigation of the rotor bearing faults of induction motors operating under different load conditions. In this analysis is performed with current and vibration based fault detection techniques. The experimental results shows the healthy and fault conditions of induction motor.



Fig 5.1 Healthy and faulty bearing

The various experimental results are obtained from experimental setup at different speed and load conditions. Figure 5.1 shows the healthy and fault bearing conditions.

5.1 Induction Motor Bearing Fault Conditions at Different Frequency

In this analysis shows that the induction motor having bearing fault conditions at different frequency like 5 Hz, 25Hz and 50 Hz.

Line Current at 5Hz & 25 Hz :

The stator voltage increases as the frequency increases which it can be seen in Figure 5.2.

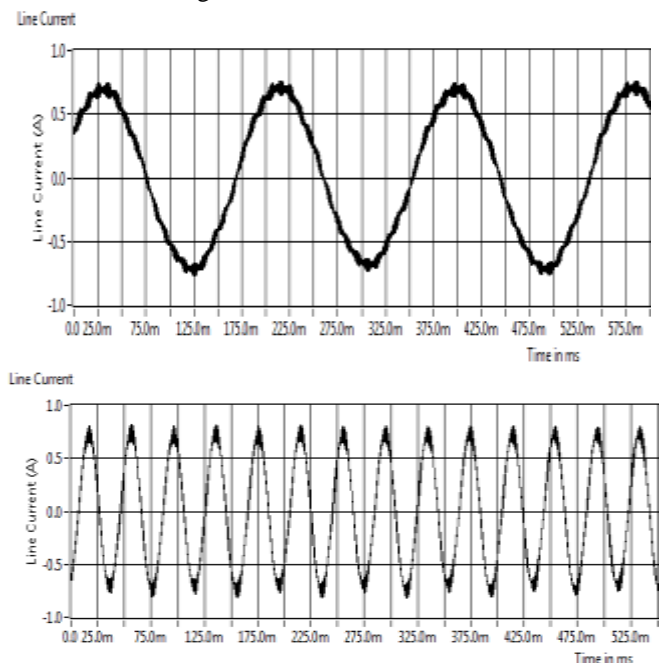

Fig 5.2 Line current waveforms in fault

Condition

Vibration at 5 Hz & 25 Hz:

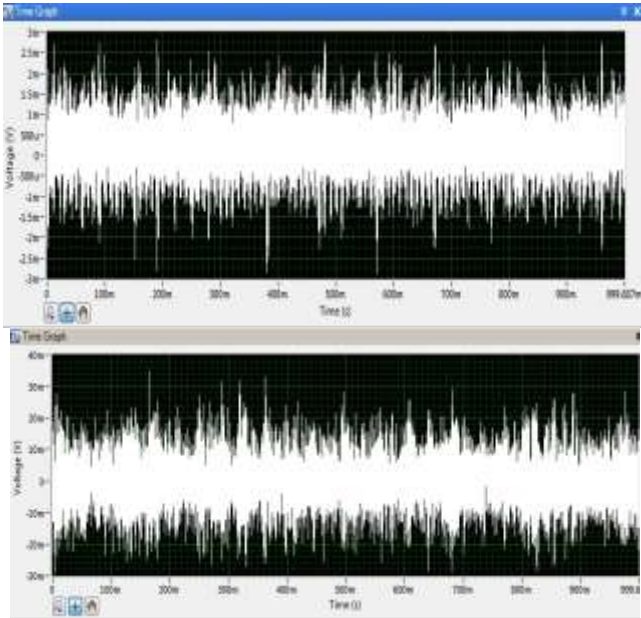

Fig 5.3 Vibration waveforms in fault condition

5.2 Induction Motor Healthy Conditions at Different Frequency

In this analysis shows that the induction motor having bearing fault conditions at different frequency like 5 Hz, 25 Hz and 50 Hz.

Line Current at 5 Hz & 25 Hz:

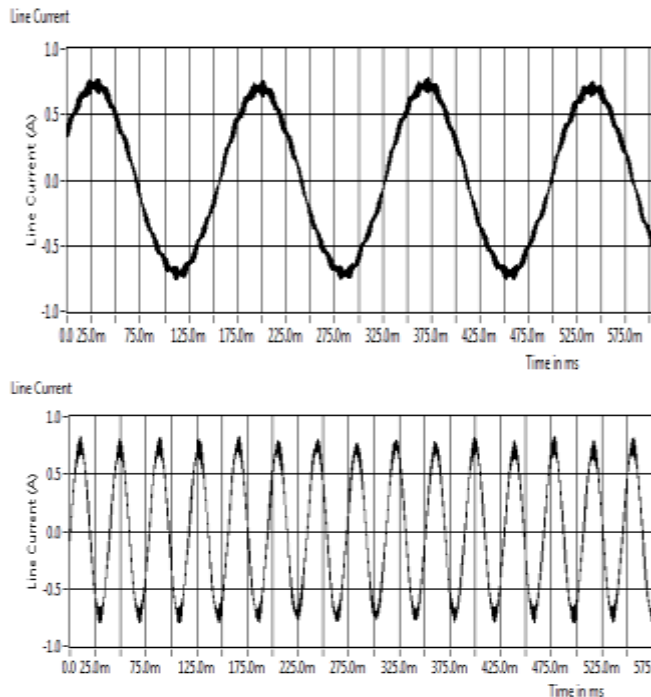

Fig 5.4 Line current waveforms in Healthy motor condition

Vibration at 5 Hz & 25 Hz:

The vibration signals are measured with vibration sensor using LabVIEW software. Figure 5.5 shows the different vibration signal at different load conditions.

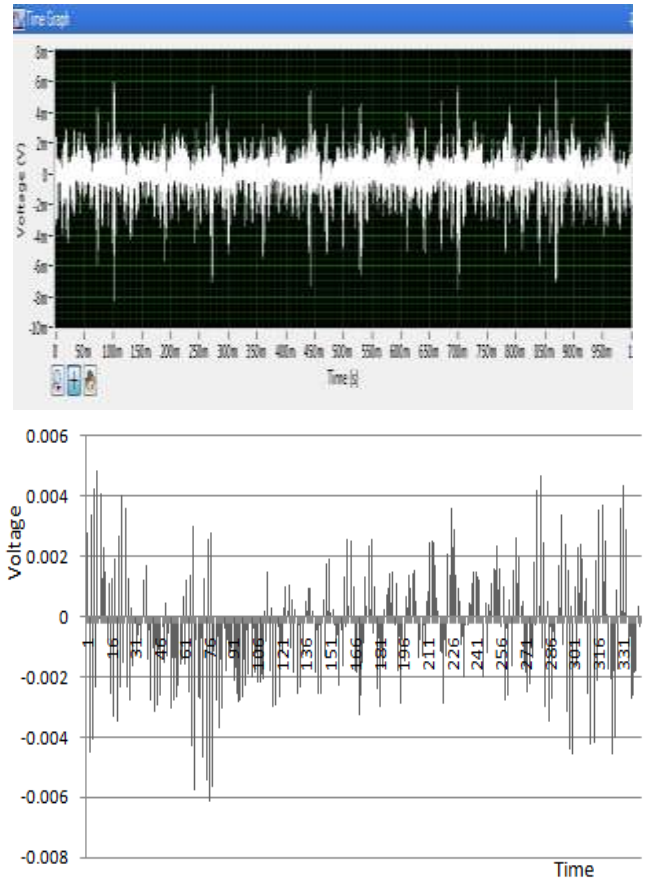

Fig 5.5 Vibration waveforms in Healthy motor condition

VI. CONCLUSION

In this work vibrations and line currents are carried out using lab VIEW software, the parameters of a three phase induction motor are monitored and controlled successfully. This paper can serve a full literature survey about various experimental results for determination of vibration and current signal at different speed and load conditions. The system developed can be used for not only industrial applications but also educational purposes, it means the whole system may be useful to colleges and various sectors. The vibration signals are measured with accelerometer, the experimental results are reported in order to verify the performance of the induction motor drive. It is hoped that this proposed method and the discussion on how to further improve the measurement accuracy and how to reduce the vibration level. The experimental analysis is done by using the Lab VIEW, which provides an efficient and accurate result.



VII. REFERENCE

- [1] Siddique, A., Yadava, G. S., & Singh, B. (2005). IEEE Transaction on Energy Conversion, A review of stator fault monitoring techniques of induction motors vol. 20, 106-114
- [2] Colak I., Celik H., Sefa I. And Demirbas S. (2005), Energy Conversion and Management, On line protection system for induction motors , 46: 2773-2786.
- [3] Baran L. (2009), MSc Thesis, A PLC based monitoring and control of power factor of a three phase induction motors, Gazi University, Institute of Science and Technology, Ankara.
- [4] Bayındır, R., Demirbas, S., Irmak, E., Bekiroglu, E (2007) ,Journal of Polytechnic-Design and implementation of microcontroller based starting and protection relay for induction motors.
- [5] Maria G. Ioannides, IEEE Trans. Energy Conversion Design and implementation of PLC-based monitoring control system for induction motor, vol. 19, no. 3, pp. 469-478, 2004.
- [6] Yao AWL, Ku CH, Electr Power Syst Res -Developing a PC-based automated monitoring and control platform for electric power systems, vol. 64, pp. 129-136, 2003.
- [7] Avlonitis SA, Pappas M, Moutesidis K, Avlonitis D, Kouroumbas K, Vlachakis N(2004), Desalination-PC based SCADA system and additional safety measures for small desalination plants, vol. 165, pp. 165-176.
- [8] Maria G. Ioannides, IEEE Trans. Energy Conversion Design and implementation of PLC-based monitoring control system for induction motor, vol. 19, no. 3, pp. 469-478.
- [9] Benbouzid, M. E., & Kliman, G. B. (2003), IEEE Transactions on Energy Conversion- What stator current processing-based techniques to use for induction motor rotor faults diagnosis, 18, 238-244.
- [10] Fang, R., & Ma, H. (2006), Proc. of the 6th World Congress on Intelligent Control and Automation Application of MCSA and SVM to induction machine rotor fault diagnosis, China, 5543-5547.
- [11] Konar, P., & Chattopadhyay, P. (2011), Applied Soft Computing- Bearing fault detection of induction motor using wavelet and Support Vector Machines (SVMs), 4203-4211.
- [12] K. Ágoston, (2014), 8th International Conference Interdisciplinarity in Engineering. Fault Detection of the Electrical Motors Based on Vibration Analysis.
- [13] M.B.R. Correa, C.B. Jacobina , A.M.N. Lima and E.R.C. da Silva, (1999). Single-phase Induction Motor Drives System , June.
- [14] Pandarakone SE, Akahori K, Matsumura T, Mizuno Y & Nakamura H, (2017) IEEE Trans. Ind. Electron. Development of a methodology for bearing fault scrutiny and diagnosis using SVM, IEEE International Conference on Industrial Technology (ICIT), pp.282-287.
- [15] Zhao H & Li L, (2017) Journal on Renewable Power Generation, Fault diagnosis of wind turbine bearing based on variational mode decomposition and Teager energy operator, Vol.11, pp. 453-460.
- [16] Prieto MD, Espinosa AG & Henao H, (2013) , IEEE Transactions on Industrial Electronics, Bearing Fault Detection by a Novel Condition-Monitoring Scheme Based on Statistical-Time Features and Neural Networks, Vol.30, pp.3398-3407

IJEAST

INTERNATIONAL JOURNAL
OF ENGINEERING APPLIED SCIENCE
AND TECHNOLOGY

ABOUT IJEAST

International Journal of Engineering Applied Science and Technology (IJEAST) is a peer-reviewed, open access journal that publishes high-quality research papers in the field of Engineering, Applied Science and Technology.

IJEAST aims to provide a platform for researchers, academicians, and professionals to share their innovative ideas, research findings, and practical experiences with the global scientific community.

FOCUS AREAS

- Engineering
- Applied Science
- Technology
- Innovation & Development
- Interdisciplinary Studies



PEER REVIEWED

All submissions are rigorously peer reviewed to ensure quality.



OPEN ACCESS

Free and unrestricted access to research for all.



GLOBAL REACH

Connecting researchers and professionals worldwide.



TIMELY PUBLICATION

We ensure a swift and efficient publication process.



For more information, visit our website

www.ijeast.com



INTERNATIONAL JOURNAL
OF ENGINEERING APPLIED SCIENCE
AND TECHNOLOGY

✉ editor@ijeast.com

🌐 www.ijeast.com

📍 India



2455-2143