



IJEAST

INTERNATIONAL JOURNAL
OF ENGINEERING APPLIED SCIENCE
AND TECHNOLOGY



VOLUME : 6 ISSUE : 7 Print / Issue Publication Date: 25-Feb-2022



ISSN : 2455-2143



DOI : 10.33564/IJEAST.2021.v06i07.023

Indexed In



WWW.IJEAST.COM

editor@ijeast.com



TEXT AND VIDEO COMMUNICATION USING Li-Fi TECHNOLOGY

Dr. D. Binu ¹, Associate Professor (G-I)
M. Pragalya ², B. Priyadarsini ³, S.Soundarya Lakshmi ⁴
¹²³⁴ Department Of ECE Sri Ramakrishna Institute Of Technology, India

Abstract— Traditionally communication has been done using radio waves, and due to this shortage there is an increasing need to look for different avenues and means for communication and therefore communication using visible light spectrum is a very promising prospect to address the situation. Li-Fi (Light Fidelity) is often used to describe high speed Visible Light Communication (VLC). VLC is dedicated to resolving the problem of lighting and communication in tandem. In our project, we aim to develop a prototype of Visible Light Based Communication link. The project consists of a transmitter, a LED, which transmits the text and video which is received by the receiver.

Keywords— Light fidelity, Visible Light Communication, Photo-diode, LED are some of the terms used in this paper.

I. INTRODUCTION

The project aims at developing a prototype to establish a communication link which uses the visible spectrum for transmission. This is popularly known as Visible Light Communication (VLC) [3]. In addition, it seeks to balance the inherent trade-off between speed and distance with respect to accuracy. The final aim is to reach data rates of 1Mbps at 50cm with accuracy over 99%.

The project's concept aims to create a visible light communication link in which text and video are taken from a

file, transferred over the link, and then saved in a file at the receiving end [7]. The challenge is not only in designing the hardware and the software systems individually but also in designing and implementing a seamless integration between the two [11]. The heart of this technology is a new generation high brightness LED'S which Visible light communication.. The visible light communication is data communication technique using visible light between 400 THz and 800 THz as an optical [8].

II. EXISTING ALGORITHM

Communication between devices is very frequent in today's environment. For short-range wireless transmissions, these devices use radio waves. Wi-Fi and Bluetooth are the two most popular short-range wireless technologies today. Bandwidth consumption, efficiency, availability, and security are all significant limits of the radio wave spectrum.

A. Related Works

The Li-Fi technology are being developed to improve the data rate, efficiency and low power consumption. Li-Fi is a bidirectional network system and provides a substantially similar experience as Wi-Fi to the user. As we move toward the future, the connectivity demands are going to increase exponentially. We'll need a network with a higher spectral capacity to handle these demands. With Li-Fi, we may be able to employ a spectrum 100000 times greater than that of radio frequency. Li-Fi now has the ability to deliver massive amounts of data and capacity.

III. PROPOSED ALGORITHM

In terms of hardware, a typical communication system has two parts, one each on the transmission and the reception end. Also to ensure synchronous transmission of data, the complexity of the receiver increases. Thus keeping in mind the above broad categorizations, the Hardware Module of the Project essentially consists of 4 sub systems, namely:

- 1.The Transmitter Circuit
- 2.The Receiver Circuit
- 3.The Clock Synchronization Circuit

The second and the third part together form the hardware at the receiver while the fourth system is essentially added to make the system portable.

The transmitter circuit has to essentially take the input data and send it over the link. The receiver circuit is designed to capture the data from the link and filter and process the waveform. The clock synchronization part, as the name suggests, enables the synchronous reception of data by recovering the clock. Clock

Synchronization Circuit can further be subdivided into

- Differentiator
- PLL
- Manchester Decoder

In addition to this hardware part, we have a software part.

The data from a file is read into the tivaC board at the transmission end. the data is encoded using Manchester encoding, and then sent out on a pin at the essential frequency. The output of this pin serves as the input to the transmitter circuit. At the receiving end, the hardware itself does the decoding and hence it is just required for the tivaC to read the data, gather it, and deliver it through the USB connection the recipient computer. A shift register is used to read four pins at the same time. There is also a protocol for starting and halting the reception.

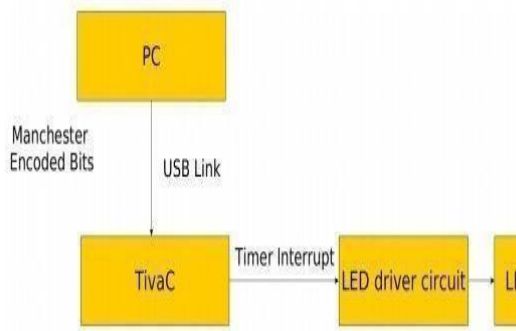

Fig.1. Transmitter Section

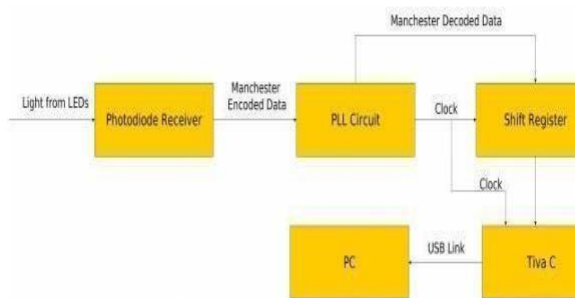

Fig.2. Receiver Section

IV. EXPERIMENT AND RESULT

We have been able to transfer the text, temperature recorded voice on the receiver side through the help of light source which is present on the transmitter side. A proper audible sound is heard

on the speaker, the temperature is detected accurately and the text is displayed exactly. This technology has a lot of potential in the future The solution of the problem dealing with the integration of visible light with a communication system is demonstrated here. This system can be used with the present infrastructure, without undergoing major changes. In the field of wireless communications, visible light communication is a rapidly emerging technology. As there are many challenges in this fields but there are equal or more advantages with it as well. With the introduction and usage of VLC, many of our long-faced problems such as power and environmental issued can potentially be solved. The VLC is still in its beginning stage, but with the rapid improvements being made in this technology stage by stage, it will be used in our daily life soon. In spite of the research problems, it is our belief that VLC system will become one of the most promising and prominent technologies in the field of wireless communication for the future generations.

A. TRANSFER OF TEXT

At first the text will be typed to the source like computer /laptop/palmtop/mobile, etc in order to keep the thing to be transmitted ready. Then the transmitting side will work in accordance with the text that is needed to be transferred. The text will be sent to the PC of the transmitter side in and the text will be coded in a form to proceed for the further processing. Once the code is ready, it will be transferred to the converter where the text that is in coded form is converted to the light form. Then the datas are transferred to the receiver side when it is being placed within the range of the light. From there the coded text is decoded and then sent to the receiver output. The output is then retrieved from the source on the receiver Side.

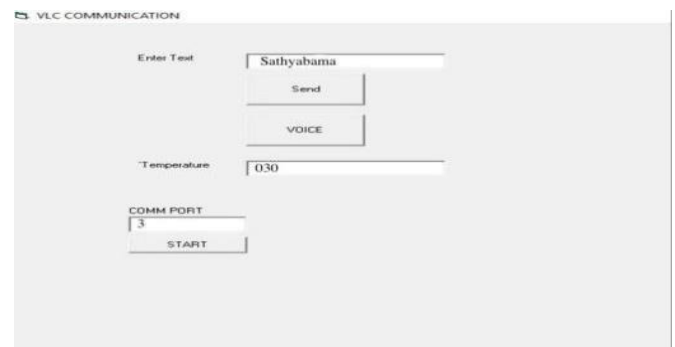

Fig .3. Result of text Input screen

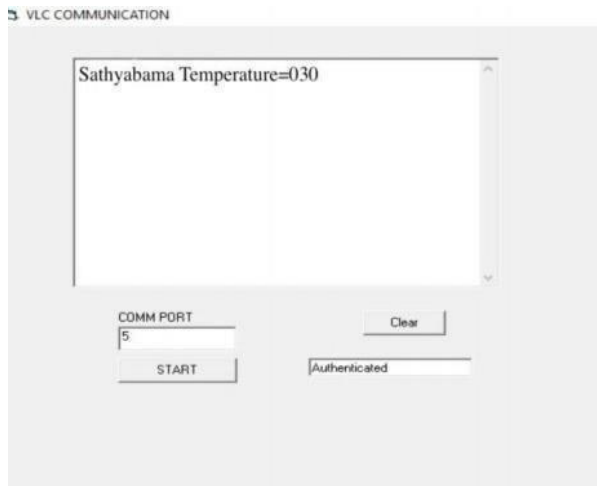

Fig.4. Result of text output screen

B. TRANSFER OF VIDEO

At first the video will be selected from source like computer /laptop/palmtop/mobile, etc in order to keep the thing to be transmitted ready. Then the transmitting side will work in accordance with the video that is needed to be transferred. The video will be sent to the PC of the transmitter side in and the video will be coded in a form to proceed for the further processing. Once the code is ready, it will be transferred to the converter where the video that is in coded form is converted to the light form. Then the data's are transferred to the receiver side when it is being placed within the range of the light. From there the coded video is decoded and then sent to the receiver output. And then the output is obtained on the source present on the receiver side.

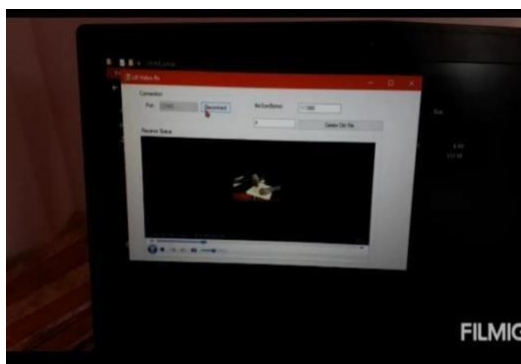

Fig.5. Result of video output screen

	Data Transferred B/s	Time Taken/s
Transfer of Text	5	1
Transfer of Video	20	120

Table -1 Experiment Result

Table 1 show the performance of our proposed method of Li-Fi Technology with respect to the data transferred and time taken.

V. CONCLUSION

Li-Fi is an emerging technology as the Radio Wave Communication has certain drawback. Li-Fi is categorized as reliable communication technique as it provides high data security transmission with low cost. The Li-Fi module for transmitting and receiving video is successfully created and tested in this proposed work. In text transmission prototype, the encoding and decoding can be used in the transmitter part and receiver part to reduce the error in transmission. VLC is still in a very early stage, however it is a promising technology with a wide range of prospective applications. The interest in VLC is increasing throughout the world and we can soon expect many real-world applications

VI. REFERENCE

- [1] N. Kumar, D. Terra, N. Lourenco, L. N. Alves, and R. L. Aguiar, "Visible light communication for intelligent transportation in road safety applications," in Proc. 7th Int. WirelessCommun. Mobile Comput. Conf, pp.1513–1518,2011.
- [2] Jyoti Rani, Perna Chauhan, Ritika Tripathi, "Li-Fi (Light Fidelity)-The future technology In Wireless communication", International Journal of Applied Engineering Research, vol. 7 No.11, , ISSN 0973-4562,2012.
- [3] Jia-yuan WANG, Nian-yu ZOU, Dong WANG, Kentaro IRIE, Zensei IHA, Yoshinori NAMIHIRA," Experimental study on visible light communication based on LED", The Journal of China Universities of Posts and Telecommunication, vol. 19, Supplement 2, Jan 2012.
- [4] Megha Goyal, Dimple Sapuro, Asha Bhagashra," New Epoch of Wireless Communication: Light Fidelity", International



Journal of Innovative Research in Computer and Communication Engineering, Vol. 1, Issue 2, ISSN (Print): 2320-9798, ISSN (Online): 2320-9801, Jan 2012.

and localization of underwater robots with application to non-destructive nuclear reactor inspection”, in Proc. IEEE Int. Conf. Robot. Autom. pp. 2445– 245.

- [5] J. K. Kim and E. F. Schubert, “Transcending the replacement paradigm of solid-state lighting,” *Opt. Exp.*, vol. 16, no. 26, pp. 21 835–21 837, Dec. 2008.
- [6] J. Park, “Speedup of dynamic response of organic lightemitting diodes,” *J. Lights. Technol.*, vol. 28, no. 19, pp. 2873– 2880, Oct. 2010.
- [7] Ian Lim, “Li-fi Internet at the speed of light,” vol. 2, no. 1, pp. 1–39, 2011.
- [8] Dominic O’Brien, Hoa Le Minh, Lubin Zeng, Grahame Faulkner and Hsi Hair Chou, Kyungwoo Lee, Daekwang Jung, YunJae Oh, Eun Tae Won, “Visible Light Communication: Recent Progress and Challenges”, *Wireless World Research Forum*. pp. 445-446, USA, Jan. 2011.
- [9] C. Quintana, V. Guerra, J. Rufo, J. Rabadan, and R. Perez Jimenez, “Reading lamp-based visible light communication system for in-flight entertainment,” *IEEE Trans. Consum. Electron.*, vol. 59, no. 1, pp. 31– 37, Feb. 2012.
- [10] Z. Jia, “A visible light communication based hybrid positioning method for wireless sensor networks,” in *Proc. Int. Conf. Intell. Syst. Design Eng. Appl.*, pp. 1367– 1370, 2012.
- [11] E. Monteiro and S. Hranilovic, “Constellation design for color-shift keying using interior point methods,” in *Proc. IEEE GLOBECOM Workshops*, pp. 1224–1228. 2012.
- [12] G. Cossu, A. M. Khalid, P. Choudhury, R. Corsini, and E. Ciaramella, “Long distance indoor high speed visible light communication system based on RGBLEDs,” in *Proc. Asia Commun. Photon. Conf.* pp. 1–3., 2012.
- [13] Rajagopal, S., Roberts, R.D., Sang-Kyu Lim, “IEEE 802.15.7 visible light communication: modulation schemes and dimming support”, *IEEE Communications Magazine*, Volume 50, Issue 3, pp. 72 - 82, March 2012.
- [14] I. Rust and H. H. Asada, “A dual-use visible light approach to integrated communication
- [15] Vismaya V Nair, N Sridhar, K Venkateswaran, “Li-Fi based Data Transmission for Underwater Communication”, in 6th International Conference on Communication and Electronics Systems (ICCES), 925929, 2021.

IJEAST

INTERNATIONAL JOURNAL
OF ENGINEERING APPLIED SCIENCE
AND TECHNOLOGY

ABOUT IJEAST

International Journal of Engineering Applied Science and Technology (IJEAST) is a peer-reviewed, open access journal that publishes high-quality research papers in the field of Engineering, Applied Science and Technology.

IJEAST aims to provide a platform for researchers, academicians, and professionals to share their innovative ideas, research findings, and practical experiences with the global scientific community.

FOCUS AREAS

- Engineering
- Applied Science
- Technology
- Innovation & Development
- Interdisciplinary Studies



PEER REVIEWED

All submissions are rigorously peer reviewed to ensure quality.



OPEN ACCESS

Free and unrestricted access to research for all.



GLOBAL REACH

Connecting researchers and professionals worldwide.



TIMELY PUBLICATION

We ensure a swift and efficient publication process.



For more information, visit our website
www.ijeast.com



INTERNATIONAL JOURNAL
OF ENGINEERING APPLIED SCIENCE
AND TECHNOLOGY

✉ editor@ijeast.com

🌐 www.ijeast.com

📍 India



2455-2143