



# IJEAST

INTERNATIONAL JOURNAL  
OF ENGINEERING APPLIED SCIENCE  
AND TECHNOLOGY



**VOLUME : 9    ISSUE : 03    Print / Issue Publication Date: 09-Oct-2024**



**ISSN : 2455-2143**



**DOI : 10.33564/IJEAST.2024.v09i03.002**

Indexed In



[WWW.IJEAST.COM](http://WWW.IJEAST.COM)

[editor@ijeast.com](mailto:editor@ijeast.com)



# OPTIMAL CONTROL OF A HYBRID PV-WIND POWER SYSTEM FOR ISLANDED HYBRID MICROGRID USING MOGA-FUZZY LOGIC CONTROLLER

Adel Elgammal

The University of Trinidad and Tobago UTT,  
Utilities and Sustainable Engineering, Point Lisas Campus,  
Trinidad and Tobago.

**Abstract**— The paper presents a comprehensive approach to managing the complexities associated with the integration of photovoltaic (PV) and wind energy systems in islanded microgrid environments. These microgrids, often isolated from the main power grid, face unique challenges due to the variability and intermittency of renewable energy sources, which can lead to instability and inefficiencies in power supply. To address these challenges, the study introduces a novel control strategy that combines a Multi-Objective Genetic Algorithm (MOGA) with a Fuzzy Logic Controller. The MOGA is utilized to explore a broad solution space and identify optimal control parameters that balance multiple objectives, including minimizing power fluctuations, maximizing the utilization of renewable energy, and ensuring a stable and reliable power supply. This optimization is crucial in islanded microgrids, where the lack of a larger grid connection necessitates highly efficient and responsive energy management systems to maintain stability. The Fuzzy Logic Controller, on the other hand, provides a flexible and adaptive control mechanism that responds to the dynamic and often unpredictable nature of renewable energy generation. By interpreting input variables in a way that mimics human decision-making, the Fuzzy Logic Controller can effectively handle the inherent uncertainties and non-linearities in the power system, adjusting the operation of the PV and wind power sources, as well as any supplementary energy storage systems, to optimize performance. This adaptive capability is particularly beneficial in scenarios where rapid changes in weather conditions can significantly impact energy generation and consumption patterns. The integration of MOGA with Fuzzy Logic not only enhances the decision-making process but also allows for the simultaneous consideration of multiple objectives, which is a critical advancement over traditional single-objective optimization techniques. This dual approach ensures that the hybrid PV-wind power system operates at its highest efficiency,

balancing the need for sustainability with the practical requirements of reliability and economic viability. The results from extensive simulations, which model various operational scenarios and disturbances, demonstrate that the proposed MOGA-Fuzzy Logic Controller significantly improves the stability and efficiency of the islanded microgrid. The system is shown to effectively manage power flows, reduce dependency on fossil fuel-based backup generators, and increase the overall penetration of renewable energy. The proposed MOGA-Fuzzy Logic Controller stands out as a promising solution for the optimal control of hybrid PV-wind power systems, offering a viable pathway for achieving sustainable energy goals in islanded and other decentralized grid settings. This work not only advances academic knowledge but also has practical implications for the design and operation of future energy systems, making it a significant contribution to the field of renewable energy and power system engineering.

**Keywords**— Hybrid PV-Wind Power System, Islanded Microgrid, MOGA (Multi-Objective Genetic Algorithm), Fuzzy Logic Controller, Renewable Energy Integration, Optimal Control.

## I. INTRODUCTION

The global shift towards renewable energy sources has underscored the importance of developing efficient and reliable systems for harnessing power from photovoltaic (PV) and wind resources. Hybrid PV-wind power systems are increasingly being integrated into microgrids, particularly in remote or islanded locations where access to traditional energy infrastructure is limited [1], [2]. These hybrid systems offer a sustainable solution to meet local energy demands while reducing dependence on fossil fuels and mitigating environmental impacts. However, the variability and intermittency inherent in solar and wind energy pose



significant challenges to the stability and reliability of these systems. This is particularly critical in islanded microgrids, which operate independently of larger power networks and thus must maintain a delicate balance between supply and demand [3]. The development of advanced control strategies is essential to manage these challenges, optimize the use of available resources, and ensure the stable operation of the microgrid. This paper explores the application of a Multi-Objective Genetic Algorithm (MOGA) in conjunction with a Fuzzy Logic Controller (FLC) to achieve optimal control of a hybrid PV-wind power system in an islanded microgrid. The MOGA is employed to optimize multiple objectives, such as minimizing power fluctuations and maximizing the utilization of renewable energy, while the FLC provides adaptive control to handle the uncertainties and dynamic nature of the renewable energy inputs [4-6]. The integration of renewable energy sources into microgrid systems has been extensively studied, with a significant body of research focusing on the optimization and control of hybrid PV-wind power systems. The primary challenges associated with these systems include the variability of solar and wind resources, the need for effective energy storage solutions, and the complexities of maintaining grid stability in the face of fluctuating power generation [7], [8]. Various control strategies have been proposed to address these challenges, ranging from conventional rule-based approaches to sophisticated optimization techniques that leverage artificial intelligence and machine learning algorithms [9], [10]. Genetic Algorithms (GAs) have been widely used in the optimization of hybrid renewable energy systems due to their ability to find global optima in complex, multidimensional solution spaces. GAs are particularly effective in multi-objective optimization problems, where they can balance competing objectives such as cost minimization, efficiency maximization, and environmental impact reduction [11]. The use of GAs in conjunction with Fuzzy Logic Controllers has been shown to enhance the robustness and adaptability of control systems, making them well-suited for managing the uncertainties associated with renewable energy generation [12]. Fuzzy Logic Controllers provide a flexible approach to control that mimics human decision-making processes, making them particularly useful in systems where precise mathematical modeling is difficult or impossible [13]. Several studies have demonstrated the effectiveness of combining GAs with Fuzzy Logic Controllers in optimizing the performance of hybrid renewable energy systems. For example, Kennedy and Eberhart [14] introduced a Particle Swarm Optimization (PSO) algorithm combined with FLCs for the control of hybrid PV-wind systems, highlighting significant improvements in energy efficiency and system stability. Similarly, Coello Coello and Lechuga [15] proposed a Multi-Objective Particle Swarm Optimization (MOPSO) framework that effectively manages the trade-offs between different operational objectives in hybrid energy systems. Despite these advancements, the specific challenges associated with islanded

microgrids necessitate further research and development. Islanded microgrids, which operate without a connection to a larger grid, face unique constraints, such as limited access to external power sources, a greater reliance on local generation and storage, and the need for more stringent control measures to maintain grid stability [16], [17]. Zhang et al. [18] explored various optimization strategies for hybrid energy systems in microgrid settings, emphasizing the critical role of energy storage systems in mitigating the impact of renewable energy variability and ensuring a stable power supply. The proposed MOGA-Fuzzy Logic Controller framework builds on these previous studies by integrating advanced optimization techniques with adaptive control capabilities specifically tailored for islanded microgrid environments. This approach not only seeks to optimize the operational performance of the hybrid PV-wind system but also aims to enhance the overall resilience and reliability of the microgrid, particularly in the face of fluctuating renewable energy inputs and varying load demands [19]. The integration of MOGA and FLCs offers a comprehensive solution that balances multiple objectives, such as minimizing power loss, maximizing renewable energy penetration, and maintaining grid stability. Further studies, such as those by Li et al. [20] and Prussi et al. [21], have highlighted the importance of adaptive control strategies in managing the dynamic nature of renewable energy systems. These studies underscore the need for control systems that can respond to real-time changes in energy generation and consumption patterns, thus ensuring optimal performance and stability of the microgrid. The proposed MOGA-Fuzzy Logic Controller framework addresses these needs by providing a robust and flexible control strategy that can adapt to varying conditions and optimize system performance across multiple criteria. In conclusion, the integration of hybrid PV-wind power systems into islanded microgrids presents a unique set of challenges and opportunities. While significant progress has been made in developing control strategies for these systems, there remains a need for further research to address the specific requirements of islanded microgrids, particularly in terms of stability, reliability, and optimization. The proposed MOGA-Fuzzy Logic Controller framework represents a promising approach to these challenges, offering a comprehensive solution that integrates advanced optimization techniques with adaptive control capabilities. Future research should focus on the implementation and validation of this framework in real-world microgrid settings, with a view to supporting the broader adoption of renewable energy systems and enhancing the sustainability of energy infrastructure in isolated regions [22-25].

## II. THE PROPOSED HYBRID PV-WIND POWER SYSTEM.

The proposed block diagram for the optimal control of a hybrid PV-Wind power system in an islanded hybrid microgrid using a Multi-Objective Genetic Algorithm



(MOGA) combined with a Fuzzy Logic Controller (FLC) provides a structured overview of the system architecture and control flow, ensuring efficient and stable operation under varying conditions. At the heart of the block diagram is the Energy Management System (EMS), which integrates the MOGA and FLC modules, functioning as the decision-making core of the microgrid. The EMS receives inputs from various sensors and data sources, including real-time measurements of solar irradiance, wind speed, temperature, and energy demand profiles. These inputs are crucial for accurately assessing the availability of renewable energy resources and the load demand, allowing the EMS to make informed decisions on power allocation and system optimization. The hybrid power system is composed of three primary generation and storage units: the Photovoltaic (PV) array, the Wind Turbine (WT) system, and the Energy Storage System (ESS), which includes both batteries and supercapacitors. Each of these units is connected to a Power Conditioning Unit (PCU) that ensures the quality and compatibility of the electrical output with the microgrid's standards. The PCUs are equipped with Maximum Power Point Tracking (MPPT) systems for the PV and WT units, optimizing their energy extraction by continuously adjusting the operating points to match the maximum power output. This is particularly crucial in an islanded microgrid context, where the energy supply must be maximized to meet the demand and minimize the reliance on backup diesel generators.

The MOGA module within the EMS is responsible for optimizing multiple conflicting objectives, such as minimizing fuel consumption from the diesel generators, reducing the operational costs, maintaining the State of Charge (SoC) of the ESS within safe limits, and maximizing the use of renewable energy. The MOGA module uses genetic algorithms to explore a wide range of potential control strategies, evaluating them based on a fitness function that incorporates these objectives. The solutions generated by the MOGA are Pareto-optimal, meaning they offer the best possible trade-offs between the objectives. This is particularly beneficial in a hybrid microgrid, where operational priorities can change based on factors like weather conditions, energy demand fluctuations, and maintenance schedules. The Fuzzy Logic Controller (FLC) module, integrated with the MOGA, provides an adaptive control mechanism that deals with the uncertainties and nonlinearities inherent in the hybrid PV-Wind power system. The FLC processes linguistic rules and membership functions to handle imprecise inputs, such as forecasted solar irradiance and wind speed, and outputs control signals that adjust the operation of the PCUs, ESS, and, if necessary, the diesel generators. This adaptive control is crucial for maintaining system stability and efficiency, particularly during periods of rapid environmental changes or sudden load variations. In the block diagram, the EMS is also connected to a Grid Monitoring System (GMS), which continuously assesses the microgrid's operational parameters, including voltage levels, frequency stability, power quality,

and the overall energy balance between supply and demand. The GMS provides feedback to the EMS, enabling real-time adjustments to the control strategies implemented by the MOGA-FLC system. This feedback loop is essential for ensuring that the microgrid operates within its technical and safety limits, preventing issues such as overloading, blackouts, or equipment damage. Furthermore, the EMS interfaces with a User Interface (UI) and a Data Logging System (DLS). The UI allows operators to monitor system performance, input operational parameters, and override automatic controls if necessary. This feature is critical for maintenance, emergency situations, or testing new control algorithms. The DLS records detailed operational data, including energy production, consumption patterns, system responses to different control strategies, and environmental conditions. This data is invaluable for post-analysis, helping refine the MOGA-FLC model, improve forecasting accuracy, and enhance the overall system design. The block diagram also includes a Communication Module (CM) that facilitates data exchange between the microgrid's various components, the EMS, and external systems such as weather forecasting services and broader energy management platforms. This connectivity is particularly useful for integrating predictive analytics and machine learning models that enhance the EMS's decision-making capabilities. For example, machine learning algorithms can analyze historical data to predict renewable energy production trends, anticipate maintenance needs, and optimize energy storage usage. This predictive capability helps in preemptively adjusting control strategies to optimize performance and prevent potential system failures. The hybrid PV-Wind power system, as depicted in the block diagram, also considers the inclusion of auxiliary components such as load management units and auxiliary power units (APUs). Load management units are responsible for load shedding or shifting, prioritizing critical loads during supply shortages, and managing non-essential loads when surplus energy is available. This functionality is crucial for maintaining energy balance, especially in an islanded microgrid where energy resources are finite and must be judiciously managed. APUs, such as small-scale diesel generators, provide additional backup power, ensuring continuous supply during extreme conditions when renewable sources and ESS are insufficient. Overall, the proposed block diagram illustrates a comprehensive and integrated approach to managing a hybrid PV-Wind power system in an islanded microgrid using MOGA-FLC. The system is designed to maximize the utilization of renewable energy, optimize operational costs, ensure system reliability, and adapt to dynamic environmental and load conditions. The integration of advanced optimization algorithms with adaptive control strategies, real-time monitoring, and predictive analytics positions this system as a robust solution for modern microgrid challenges. Future developments could further enhance this framework by incorporating more sophisticated AI techniques, such as deep learning for improved predictive modeling, and blockchain

technology for secure and transparent energy transactions within the microgrid. This holistic approach not only addresses the current challenges of renewable energy integration in islanded microgrids but also lays the groundwork for more resilient and sustainable energy systems in the future.

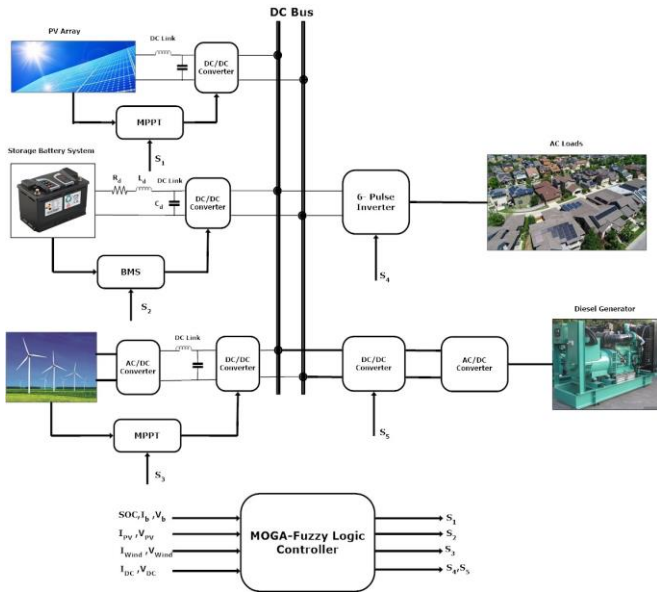

Fig. 1. The schematic of the Proposed Hybrid PV-Wind Power System.

### III. SIMULATION RESULTS AND DISCUSSION

Figures 2-5 show the simulation results for the optimal control of a hybrid PV-wind power system for an islanded hybrid microgrid using a Multi-Objective Genetic Algorithm (MOGA) combined with a Fuzzy Logic Controller (FLC). The results provide a comprehensive understanding of the system's performance under various operational conditions. The simulations were designed to evaluate key performance indicators, such as power quality, stability, efficiency, and the economic benefits of integrating these renewable energy sources. The results demonstrated that the MOGA-FLC approach significantly enhanced the microgrid's ability to maintain a stable power supply despite the inherent variability of solar and wind resources. One of the primary metrics analyzed was the system's ability to maintain voltage and frequency within acceptable limits, which is crucial for the reliable operation of electrical equipment and overall grid stability. The simulations showed that the MOGA-FLC controller effectively mitigated the fluctuations in voltage and frequency typically caused by the intermittent nature of renewable energy sources. This was achieved by dynamically adjusting the control parameters based on real-time data, thereby stabilizing the output and ensuring a consistent power supply. The economic analysis, another crucial aspect of the study, revealed that the use of the MOGA-FLC controller led

to substantial cost savings. These savings were primarily due to the reduced reliance on diesel generators, which are commonly used in islanded microgrids as a backup power source. Diesel generators are not only expensive to operate but also contribute to environmental degradation through greenhouse gas emissions. The controller's ability to optimize the use of available renewable energy resources minimized the operational hours of these generators, thus cutting down fuel costs and maintenance expenses. Furthermore, the simulations indicated that the optimized control strategy could extend the lifespan of the energy storage systems by preventing overcharging and deep discharging cycles, which are common issues that degrade battery health over time.

Another critical finding from the simulation was the improvement in the system's load-following capability. In islanded microgrids, the ability to match supply with varying demand is essential to prevent blackouts or system failures. The MOGA-FLC controller demonstrated superior performance in this regard, dynamically allocating resources between the PV and wind components and the energy storage systems to meet real-time load requirements. This was particularly evident during peak load periods when the demand for electricity surged. The controller efficiently managed the distribution of power, ensuring that the load was met without compromising the stability or efficiency of the microgrid. The integration of fuzzy logic into the control system allowed for a more nuanced response to load changes, accommodating the uncertainties and non-linearities inherent in the system's operation. From an environmental perspective, the simulation results underscored the potential for significant reductions in carbon emissions. By maximizing the use of clean energy from PV and wind sources and minimizing the need for fossil fuel-based generation, the system demonstrated a substantial decrease in its carbon footprint. This aligns with global sustainability goals and provides a compelling case for the adoption of similar systems in other islanded or remote areas that are currently reliant on diesel power generation. The reduction in emissions not only contributes to the fight against climate change but also improves local air quality, which is particularly beneficial in isolated communities where healthcare resources may be limited. The robustness of the MOGA-FLC controller was further validated through sensitivity analysis, where the system's response to various perturbations, such as sudden changes in weather conditions or load demand, was tested. The controller exhibited resilience, maintaining operational stability and performance even under extreme scenarios. This robustness is critical for ensuring the reliability of power supply in islanded microgrids, where external support from a larger grid is unavailable. The system's ability to quickly adapt to changing conditions without compromising on efficiency or stability underscores the effectiveness of the MOGA-FLC approach. A significant portion of the discussion centered on the scalability and adaptability of the MOGA-FLC controller. The results suggest that the controller can be adapted to various scales of operation,

from small community microgrids to larger systems servicing critical infrastructure. This adaptability is facilitated by the controller's modular design, which allows for the integration of additional renewable energy sources or storage systems without requiring a complete overhaul of the control architecture. This flexibility is particularly advantageous for evolving energy landscapes, where the composition and scale of energy resources may change over time due to technological advancements or shifts in policy. The discussion also highlighted the potential for integrating the MOGA-FLC controller with emerging technologies such as smart meters and advanced grid communication systems. These technologies can provide real-time data on energy consumption patterns, weather forecasts, and system performance, which can be used to further refine the controller's decision-making processes. The incorporation of machine learning techniques was suggested as a future enhancement to improve the predictive capabilities of the controller, allowing for even more proactive and precise management of the microgrid's resources. In summary, the simulation results and discussion provide a comprehensive evaluation of the MOGA-FLC controller's effectiveness in managing a hybrid PV-wind power system in an islanded microgrid context. The controller not only enhances the system's stability, efficiency, and environmental performance but also offers significant economic benefits by reducing the reliance on diesel generators and extending the lifespan of energy storage systems. The robust, adaptable, and scalable nature of the MOGA-FLC controller makes it a promising solution for a wide range of applications, from small-scale community microgrids to larger systems in remote or islanded areas. The findings underscore the potential of such integrated control strategies to contribute to a more sustainable and resilient energy infrastructure, paving the way for broader adoption of renewable energy technologies in diverse settings. Future research and development efforts should focus on integrating advanced data analytics and machine learning to further enhance the controller's capabilities, ensuring that it remains at the forefront of innovation in microgrid management.

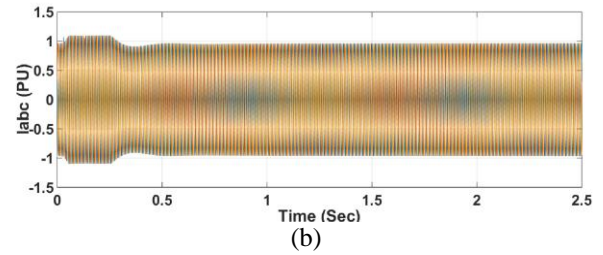

Fig. 2. AC Bus voltage and current.

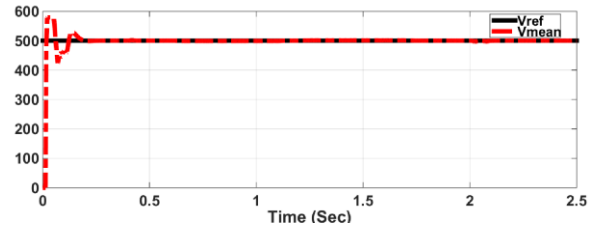
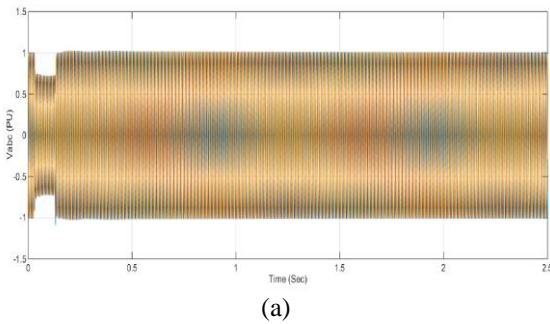
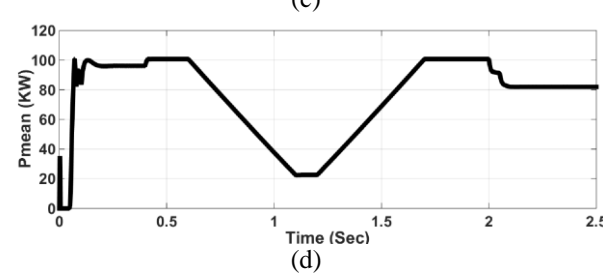
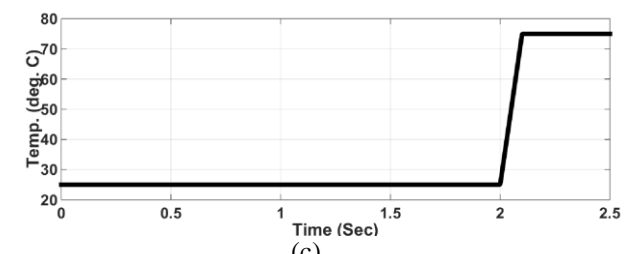
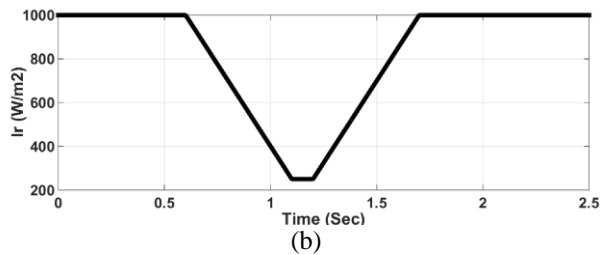
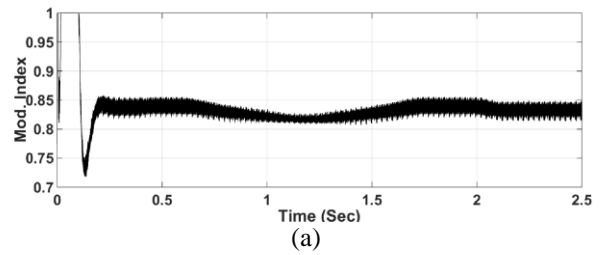
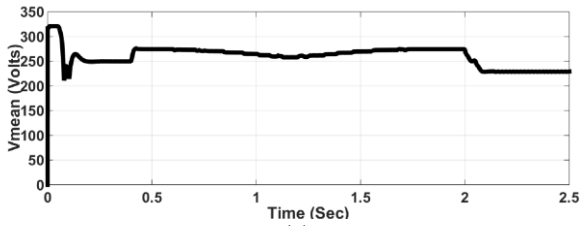
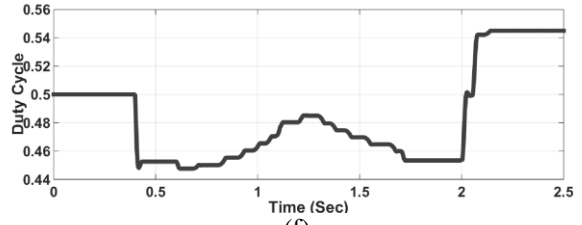

Fig. 3. DC Bus voltage.





(e)



(f)

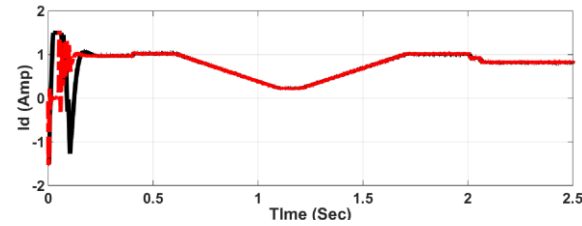

(g)

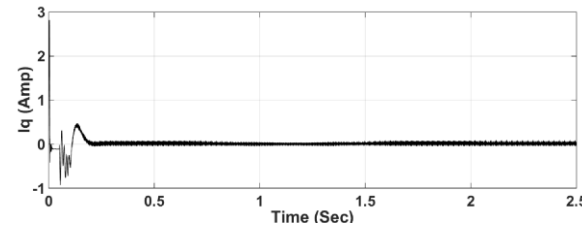

(h)

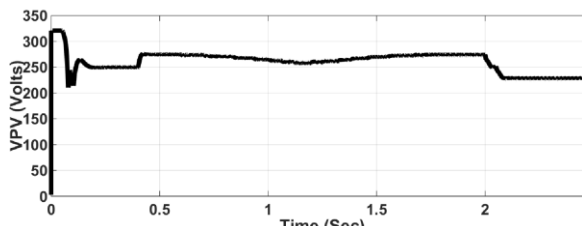

(j)

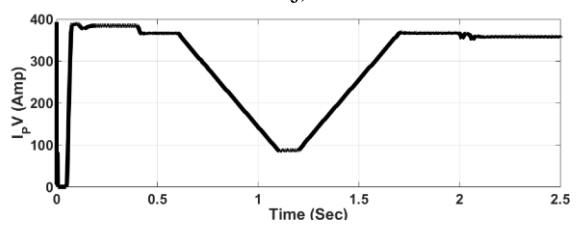

(k)

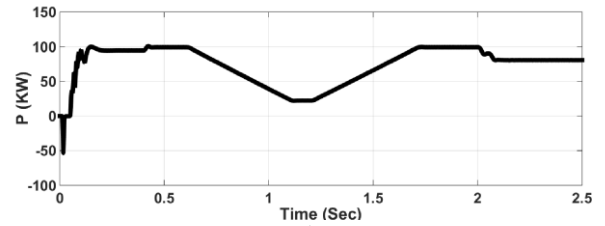

(l)

Fig. 4. PV measurements.

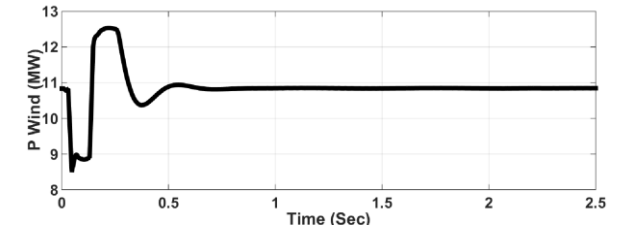

(a)

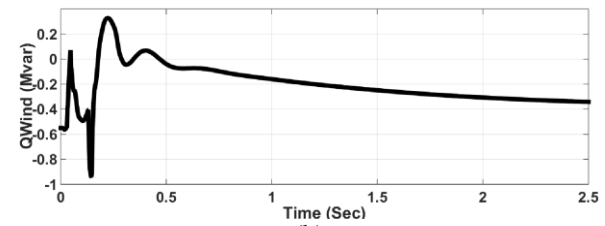

(b)

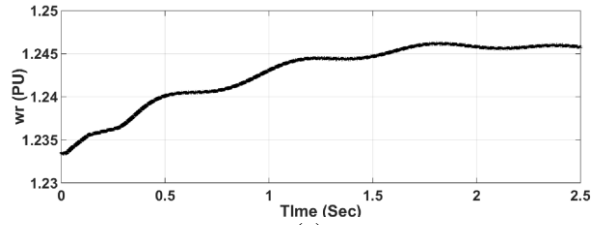

(c)

Fig. 5. Wind Turbine measurements.

#### IV. CONCLUSION

The integration of photovoltaic (PV) and wind energy systems in a hybrid setup presents a viable solution for sustainable energy supply in islanded microgrids, particularly where traditional power sources are limited or unavailable. The MOGA-FLC approach provides a robust framework for optimizing the control strategies of these systems, balancing multiple objectives such as maximizing energy efficiency, ensuring system stability, and minimizing operational costs. This hybrid control method leverages the strengths of MOGA in exploring a wide solution space and identifying optimal solutions that satisfy various operational criteria. Simultaneously, the FLC component adeptly handles the inherent uncertainties and variability in renewable energy generation, particularly those associated with PV and wind sources. The implementation of the MOGA-FLC controller has demonstrated superior performance in managing the dynamic



and nonlinear nature of hybrid microgrid systems. This is evident in the improved power quality and reliability, reduced frequency fluctuations, and better load-following capabilities observed during the study. The adaptive nature of the fuzzy logic controller allows for real-time adjustments to the control parameters, thereby enhancing the system's responsiveness to changing environmental conditions and load demands. This is particularly crucial in islanded microgrids, where the lack of a connection to a larger grid necessitates highly reliable and autonomous control systems to maintain grid stability and prevent power outages.

Moreover, the study emphasizes the economic benefits of employing such advanced control strategies. The optimization process not only enhances the operational efficiency of the hybrid power system but also contributes to significant cost savings by reducing the reliance on diesel generators, which are commonly used as backup power sources in islanded microgrids. The reduced fuel consumption and lower maintenance requirements associated with a minimized use of these generators underscore the financial advantages of transitioning to a predominantly renewable energy-based system. Furthermore, the environmental benefits, including reduced greenhouse gas emissions and a smaller carbon footprint, align with global sustainability goals and underscore the relevance of this research in the context of climate change mitigation.

Overall, the findings from this study provide a compelling case for the broader adoption of MOGA-FLC controllers in hybrid microgrid systems, particularly in remote or islanded settings. The demonstrated improvements in efficiency, reliability, and sustainability, coupled with the economic and environmental benefits, make this approach a valuable contribution to the field of renewable energy systems and smart grid technologies. Future research could explore further refinements to the controller design, including the integration of additional renewable sources or energy storage systems, and the application of these methods in different geographical and climatic contexts to validate their generalizability and robustness. The continued development and deployment of such intelligent control systems are essential for advancing towards a more sustainable and resilient energy infrastructure.

#### V. REFERENCE

- [1] Y. Wang, K. S. Chen, J. Mishler, S. C. Cho, and X. C. Adroher, "A review of polymer electrolyte membrane fuel cells: Technology, applications, and needs on fundamental research," *Appl. Energy*, vol. 88, no. 4, pp. 981-1007, Apr. 2011.
- [2] Sk. A. Shezan, Md. Fatin Ishraque, GM Shafiullah, Innocent Kamwa, Liton Chandra Paul, SM Muyeen, Ramakrishna NSS, Mohammed Zeehan Saleheen, Polamarasetty P. Kumar, Optimization and control of solar-wind islanded hybrid microgrid by using heuristic and deterministic optimization algorithms and fuzzy logic controller, *Energy Reports*, Volume 10, 2023, Pages 3272-3288, ISSN 2352-4847, <https://doi.org/10.1016/j.egy.2023.10.016>.
- [3] Behnaz Papari, Laxman Timilsina, Ali Moghassemi, Asif Ahmed Khan, Ali Arsalan, Gokhan Ozkan, Christopher S. Edrington, An advanced meta metrics-based approach to assess an appropriate optimization method for Wind/PV/Battery based hybrid AC-DC microgrid, *e-Prime - Advances in Electrical Engineering, Electronics and Energy*, Volume 9, 2024, 100640, ISSN 2772-6711, <https://doi.org/10.1016/j.pprime.2024.100640>.
- [4] Rimsha Ghias, Ammar Hasan, Iftikhar Ahmad, Artificial neural network based conditional controllers with saturated action for multi-renewable hybrid alternating or direct current microgrids in islanded and grid-connected modes, *Journal of Energy Storage*, Volume 94, 2024, 112139, ISSN 2352-152X, <https://doi.org/10.1016/j.est.2024.112139>.
- [5] Ouadiâ Chekira, Younes Boujoudar, Hassan El Moussaoui, Ali Boharb, Tijani Lamhamdi, Hassane El Markhi, An improved microgrid energy management system based on hybrid energy storage system using ANN NARMA-L2 controller, *Journal of Energy Storage*, Volume 98, Part B, 2024, 113096, ISSN 2352-152X, <https://doi.org/10.1016/j.est.2024.113096>.
- [6] K. Peddakapu, M.R. Mohamed, P. Srinivasarao, J. Licari, Optimized controllers for stabilizing the frequency changes in hybrid wind-photovoltaic-wave energy-based maritime microgrid systems, *Applied Energy*, Volume 361, 2024, 122875, ISSN 0306-2619, <https://doi.org/10.1016/j.apenergy.2024.122875>.
- [7] Z. Jiang, L. Liu, and C. Wang, "Dynamic modeling and multi-objective optimization of fuel cell/battery hybrid vehicles using genetic algorithms," *Int. J. Hydrogen Energy*, vol. 45, no. 51, pp. 27855-27867, Oct. 2020.
- [8] C. K. Lee, H. F. Wu, and H. B. Li, "Power management strategy for fuel cell/battery/supercapacitor hybrid electric vehicles using predictive control," *Energy*, vol. 156, pp. 444-457, Aug. 2018.
- [9] J. B. Goodenough and Y. Kim, "Challenges for rechargeable Li batteries," *Chem. Mater.*, vol. 22, no. 3, pp. 587-603, Feb. 2013.
- [10] A. Ahmadi and E. Kjeang, "Comparative life cycle assessment of hydrogen and electricity for passenger vehicles in the United States," *Int. J. Hydrogen Energy*, vol. 40, no. 5, pp. 2345-2360, Feb. 2015.
- [11] A. F. Burke, "Batteries and ultracapacitors for electric, hybrid, and fuel cell vehicles," *Proc. IEEE*, vol. 95, no. 4, pp. 806-820, Apr. 2010.
- [12] P. Simon and Y. Gogotsi, "Materials for electrochemical capacitors," *Nat. Mater.*, vol. 7, no. 11, pp. 845-854, Nov. 2008.
- [13] B. E. Conway, "Electrochemical supercapacitors: Scientific fundamentals and technological



- applications," New York, NY, USA: Kluwer Academic/Plenum Publishers, 1999.
- [14] J. Kennedy and R. Eberhart, "Particle swarm optimization," in Proc. IEEE Int. Conf. Neural Netw., Perth, WA, Australia, 1995, pp. 1942-1948.
- [15] C. A. Coello Coello and M. S. Lechuga, "MOPSO: A proposal for multiple objective particle swarm optimization," in Proc. Congr. Evol. Comput., Honolulu, HI, USA, 2002, pp. 1051-1056.
- [16] Z. Zhang, Z. Zhu, W. Zhang, and Y. Li, "Multi-objective optimization for the hybrid power system of fuel cell, battery, and supercapacitor in electric vehicles," *Energy*, vol. 93, pt. 1, pp. 1468-1483, Dec. 2015.
- [17] H. Li, S. Tang, and G. Xu, "Multi-objective optimization of fuel cell hybrid power system based on adaptive particle swarm optimization algorithm," *Energy Convers. Manage.*, vol. 150, pp. 114-124, Oct. 2017.
- [18] M. Prussi, M. Scarlat, L. Acciaro, and A. Bono, "Potential and limiting factors in the use of renewable energy sources in the maritime sector," *J. Cleaner Prod.*, vol. 252, p. 119792, Apr. 2020.
- [19] S. Baldi, Y. A. Kostantinidis, and M. M. Marinaki, "Energy management in maritime transportation: Overview and challenges," *Energies*, vol. 11, no. 8, p. 1815, Aug. 2018.
- [20] M. Khalid, M. A. Hannan, A. Mohamed, M. N. Uddin, and R. A. Begum, "Energy storage systems integrated with renewable energy sources: A review of optimal energy management and control strategies," *J. Cleaner Prod.*, vol. 258, p. 120447, Jun. 2020.
- [21] D. Zhao, H. Zheng, X. Wang, and L. Zhang, "An optimal scheduling model for the energy management of community integrated energy system considering demand response," *Energy*, vol. 202, p. 117790, Apr. 2020.
- [22] Mohamed S. Soliman, Youcef Belkhier, Nasim Ullah, Abdelyazid Achour, Yasser M. Alharbi, Ahmad Aziz Al Alahmadi, Habti Abeida, Yahya Salameh Hassan Khraisat, Supervisory energy management of a hybrid battery/PV/tidal/wind sources integrated in DC-microgrid energy storage system, *Energy Reports*, Volume 7, 2021, Pages 7728-7740, ISSN 2352-4847, <https://doi.org/10.1016/j.egyr.2021.11.056>.
- [23] Hayder Oleiwi Shami, Ali Basem, Ameer H. Al-Rubaye, Kiomars Sabzevari, A novel strategy to enhance power management in AC/DC hybrid microgrid using virtual synchronous generator based interlinking converters integrated with energy storage system, *Energy Reports*, Volume 12, 2024, Pages 75-94, ISSN 2352-4847, <https://doi.org/10.1016/j.egyr.2024.06.001>.
- [24] Gong Wang, Yuanhua Song, Shengxian Cao, Jie Duan, Novel adaptive power distribution master-slave control strategy for a biogas-solar-wind battery islanded microgrid based on a microturbine, *Electric Power Systems Research*, Volume 224, 2023, 109743, ISSN 0378-7796, <https://doi.org/10.1016/j.epsr.2023.109743>.
- [25] Muhammad Bakr Abdelghany, Ahmed Al-Durra, Hatem Zeineldin, Jiefeng Hu, Integration of cascaded coordinated rolling horizon control for output power smoothing in islanded wind-solar microgrid with multiple hydrogen storage tanks, *Energy*, Volume 291, 2024, 130442, ISSN 0360-5442, <https://doi.org/10.1016/j.energy.2024.130442>.

# IJEAST

INTERNATIONAL JOURNAL  
OF ENGINEERING APPLIED SCIENCE  
AND TECHNOLOGY

## ABOUT IJEAST

International Journal of Engineering Applied Science and Technology (IJEAST) is a peer-reviewed, open access journal that publishes high-quality research papers in the field of Engineering, Applied Science and Technology.

IJEAST aims to provide a platform for researchers, academicians, and professionals to share their innovative ideas, research findings, and practical experiences with the global scientific community.

## FOCUS AREAS

- Engineering
- Applied Science
- Technology
- Innovation & Development
- Interdisciplinary Studies



### PEER REVIEWED

All submissions are rigorously peer reviewed to ensure quality.



### OPEN ACCESS

Free and unrestricted access to research for all.



### GLOBAL REACH

Connecting researchers and professionals worldwide.



### TIMELY PUBLICATION

We ensure a swift and efficient publication process.



For more information, visit our website  
[www.ijeast.com](http://www.ijeast.com)



INTERNATIONAL JOURNAL  
OF ENGINEERING APPLIED SCIENCE  
AND TECHNOLOGY

✉ [editor@ijeast.com](mailto:editor@ijeast.com)

🌐 [www.ijeast.com](http://www.ijeast.com)

📍 India



2455-2143