

# HIGH GAIN MULTIPLE OUTPUT DC-DC CONVERTER

Anupa Raghunath  
Department of EEE  
M A College of Engineering,  
Kerala, India

Prof. Sija Gopinathan  
Department of EEE  
M A College of Engineering,  
Kerala, India.

Prof. Neetha John  
Department of EEE,  
M A College Engineering,  
Kerala, India

**Abstract**— A DC-DC converter is a power electronic device which converts one DC voltage level to another. The conversion of one voltage level to another is achieved by varying the duty ratio of the converter. Multiple output DC-DC converters are those which provides multiple output voltages from a single input DC supply. Multi output DC-DC converters are used in many applications such as hand held portable devices, hybrid energy systems, hybrid vehicles, cellular phones, laptop computers etc. So instead of using single converter for each load, using multiple output DC-DC converter reduces the size, cost, weight and number of components of the system. Here a new single input multiple output DC-DC converter is proposed with output voltages of opposite polarity and one of the output voltage has a considerable gain. This topology uses 3 switches to perform the power conversion, without employing any transformers. This converter is used for low power application. Simulation of the circuit is done in MATLAB/Simulink environment for verification of the theoretical analysis.

**Keywords**— Multi output, Opposite polarity output, High gain.

## I. INTRODUCTION

Nowadays most of the fields such as industries, telecommunication, plug in hybrid vehicles, etc., there will be different voltage level because of the auxiliary circuits in addition to main power circuit. In such system, Single Input Multiple output (SIMO) DC-DC converters have very good place and researches on SIMO DC-DC converters are worthy [7]. For example, such power supplies are indispensable for car audio. In general, the power used to feed the car electronics equipment, containing the engine control system, amusing system, etc., comes from the engine making the generator move and charge the 12V lead acid battery [4]. They are used for renewable energy based power systems. Such a system integrates solar and wind energy sources at the input and provides a regulated output for the load [1]. Single Input Multiple Output (SIMO) DC-DC converters are met with different types of problems. SIMO converters where individual DC-DC converters are used, the whole system will be bulky,

because of the increased number of switches. This will also increase the system cost. It should regulate each of the individual outputs precisely, to have better cross-regulation behavior due to changes in the other output and it should devise a suitable control system to coordinate the power flow between the different outputs [7]. SIMO DC-DC converters with cascaded DC-DC stages or time multiplexed and current channelized multiple output converters are the examples for non-isolated SIMO DCDC converters. In converters with cascaded DC-DC stages the system is bulky, but the control system is simple. But in the case of time multiplexed and current channelized converter the control system is very complex.

Another type of dual output converter is multi-output buck-boost (MOBB) converter, which is capable of generating several output voltages [8]. It is also used in E-cars or electric trains to stabilize voltages. High gain DC-DC converters are used in modern applications such as head lamps in cars with high ability of discharging, accelerators, RF transmission generators, modulators, X-rays generators and etc. [11]. Also many industrial and residential loads/appliances often require different supply voltages. So instead of powering each load from a separate single source, it is easy and cost-effective to use a multiple-output converter. The multiple-output converters also offer simplified number of components, reduced weight and cost and compact structure [9].

A dual output topology which uses a single input and two switches is shown in Fig 1.

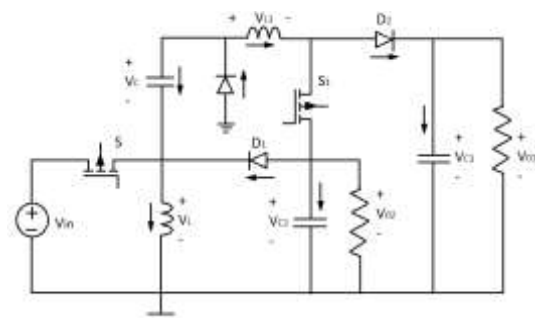

Fig. 1: Dual Output DC-DC Converter. [12]



The topology uses two switches and three diodes to perform the conversion. Output Voltage is taken across two capacitors  $C_1$  and  $C_2$ . Here two output voltages of opposite polarity is obtained and one of the outputs has a high gain.

## II. PROPOSED CONVERTER TOPOLOGY

This topology uses 3 switches to perform the power conversion, without employing any transformers. This topology can be used instead of three single output power supplies. This converter is opted for very low power application. The circuit diagram of proposed converter is shown in Fig. 2.

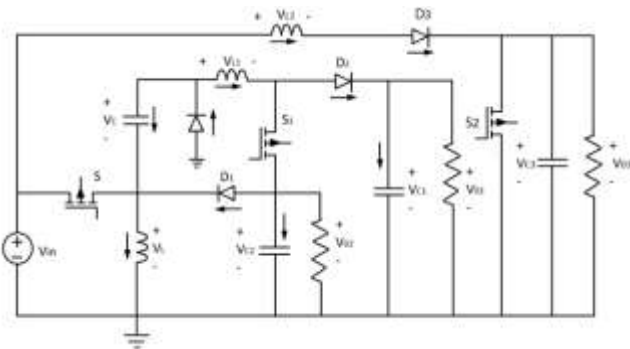

Fig. 2: Proposed High Gain Multi Output DC-DC Converter.

The working of the circuit is explained by two modes of operation. The three switches are triggered with same pulse and fixed duty cycle. Output voltages  $V_{01}$ ,  $V_{02}$  and  $V_{03}$  is taken across three filter capacitor  $C_1$ ,  $C_2$  and  $C_3$  respectively.

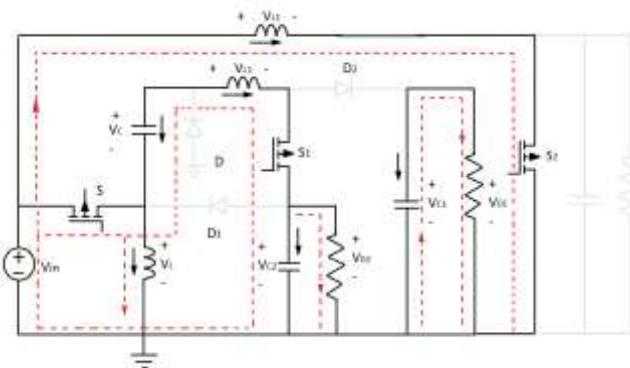

Fig. 3: Mode 1

In mode 1 all the switches are turned ON. All the inductors gets charged from the supply voltage during this time. The capacitors  $C_1$  and  $C_3$  discharges through the resistors, whereas the capacitor  $C_2$  charges. Fig. 3 shows this mode. Since  $S$  and  $S_1$  are turned ON, the output voltage is supplied by the source. The load resistance across  $C_3$  gets shorted as  $S_2$  is turned ON. The current path is as shown in Fig. 3.

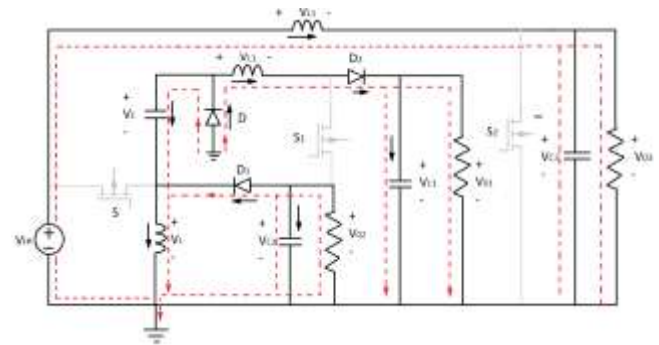

Fig.4:Mode2

All the switches are turned off in mode 2. Then the capacitors  $C_1$  and  $C_3$  charges whereas  $C_2$  discharges. The inductor  $L$  supply energy to the capacitor  $C_1$  and  $C_3$  is supplied from the source. The equivalent circuits of mode 2 is shown in Fig. 4.

From steady state analysis the gains are obtained as,

$$V_C/V_{in} = D/(1-D) \quad (1)$$

$$V_{01}/V_{in} = (D(1+D))/(1-D)^2 \quad (2)$$

$$V_{02}/V_{in} = -D/(1-D) \quad (3)$$

$$V_{03}/V_{in} = 1/(1-D) \quad (4)$$

where  $V_C$ ,  $V_{01}$ ,  $V_{02}$  and  $V_{03}$  are the voltage across capacitors  $C_1$ ,  $C_2$  and  $C_3$  respectively.

## III. CONTROL STRATEGY

The three switches are gated with same switching pulse. Switching strategy is as shown in Fig. 4. The duty ratio is taken as 0.75 with a switching frequency of 10 kHz.

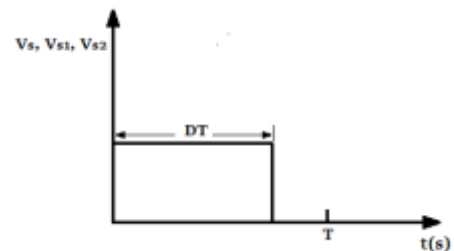

Fig. 5: Switching Strategy

## IV. SIMULATION PARAMETERS

The output current is assumed to be 50 mA. For an input voltage of 5 V and duty ratio of 0.75, the following values of inductances, capacitances and resistances are obtained. Switching frequency is taken as 10 kHz.

Table 1: Simulation Parameters



Parameters	Values
$L = L_1 = L_2$	5 mH
C	470 $\mu$ H
$C_1 = C_2 = C_3$	100 $\mu$ H
Resistance	5000 $\Omega$ , 300 $\Omega$

V. SIMULATION MODEL AND RESULTS

The circuits are drawn in Matlab/SIMULINK software. The Simulink model of high gain DC-DC converter is shown in Fig. 6.

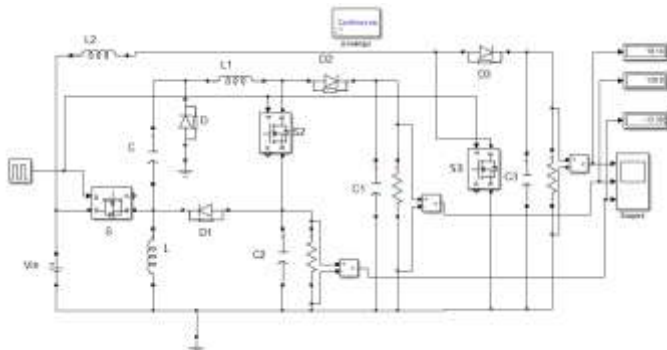

Fig. 6: Simulink Model of High Gain DC-DC Converter

The model is simulated to obtain plots of output voltage, voltage across switches, and voltage across capacitors and currents through inductors as shown in following figures.

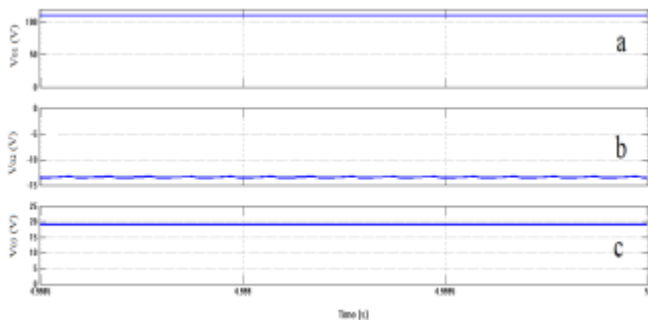

Fig. 7: (a) Output Voltage  $V_{01}$  (b) Output Voltage  $V_{02}$  (c) Output Voltage  $V_{03}$

Simulation of the proposed circuit gave output voltages 110.6 V, 19.12 and -13.15V for an input voltage of 5 V. Hence we can see that outputs of opposite polarities is obtained and one of the output has considerably high gain. Fig. 7 shows the output voltages.

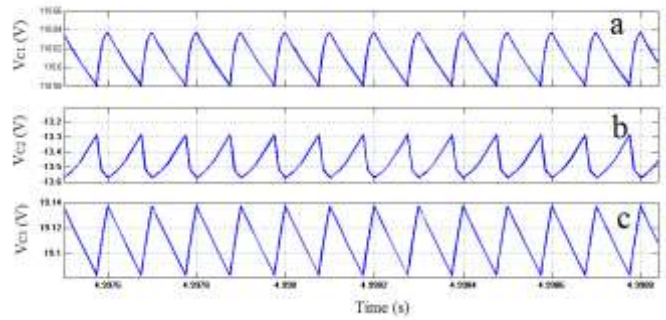

Fig. 8: (a) Voltage across  $C_1$  (b) Voltage across  $C_2$  (c) Voltage across  $C_3$

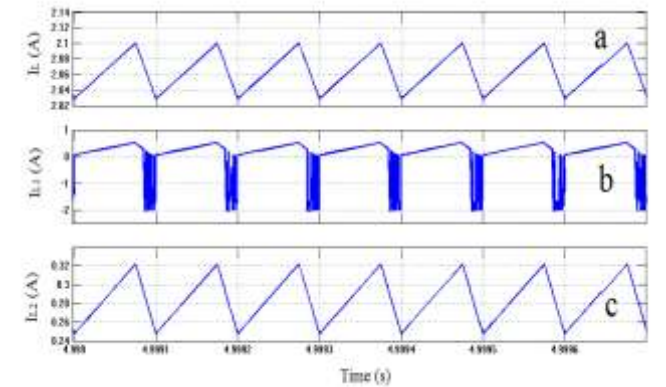

Fig. 9: (a) Current through L (b) Current through  $L_1$  (c) Current through  $L_2$

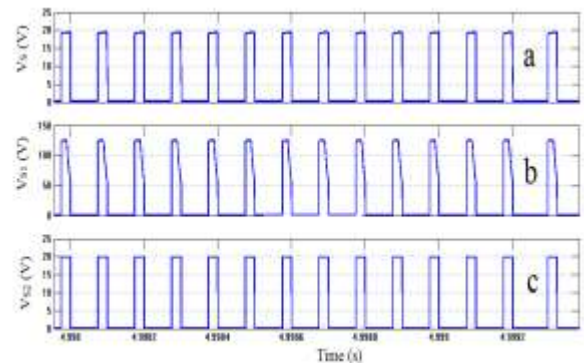

Fig. 10: (a) Voltage Stress across switch S (b) Voltage Stress across switch  $S_1$  (c) Voltage Stress across switch  $S_2$

The stress across switches is comparable with the output voltage. Since the duty ratio is high the average stress is low. The current ripple in the inductor  $L_2$  is more as compared to the dual output converter. As the capacitor value used is high, the ripple in the output voltage is also less. The ripple voltage of  $V_{01}$ ,  $V_{02}$  and  $V_{03}$  is 0.04V, 0.3V and 0.14V respectively.

**VI. EXPERIMENTAL SETUP AND RESULTS**

Experimental set up of the dual output DC-DC converter shown in Fig. 1 is done. To obtain the switching pulse micro controller PIC16F877A is used. The program for control pulse is written in microC. The program is verified and the frequency is checked by simulating the program using Proteus software. The output of the micro controller is given to a driver IC TLP250. These pulses are fed to the gate of switches in the power circuit.

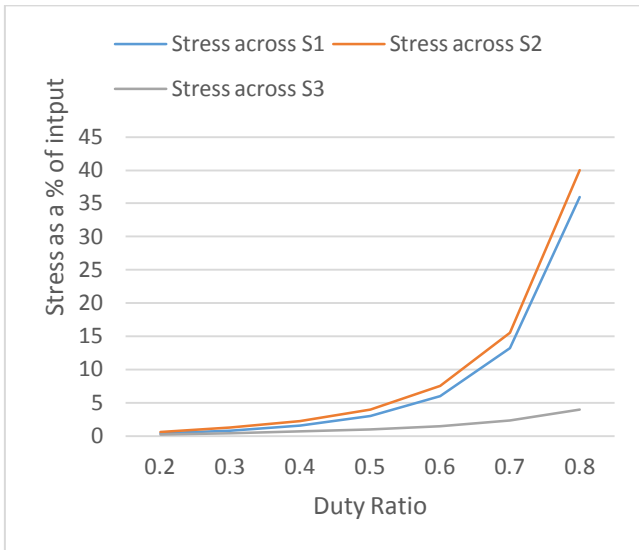

Fig. 11: Variation of stress with duty ratio

The graph shows variation of stress with duty ratio. As we increase duty ratio for increasing output voltage stress also increases. So the duty ratio must be properly selected.



Fig. 13: Experimental setup of Dual Output DC-DC Converter

The input DC voltage to the converter and microcontroller is fed from DC supply. The output is taken across two resistors.

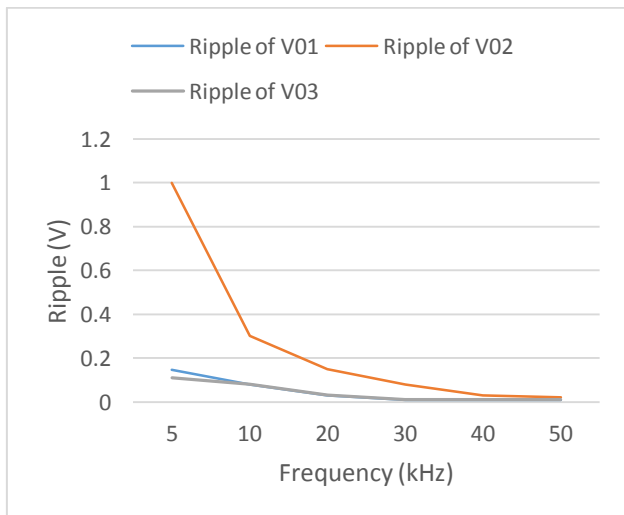

Fig. 12: Variation of ripple voltage with switching frequency

From the graph we can see that as we increase switching frequency the ripple of the output voltage decreases. When operated at high frequencies the inductor and capacitor values should be selected suitably.

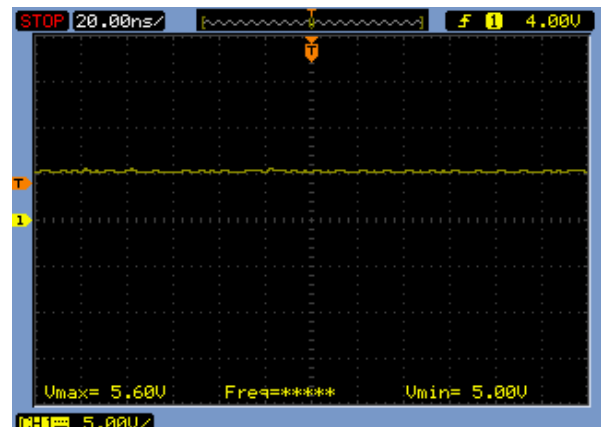

Fig. 14: Output V<sub>01</sub>

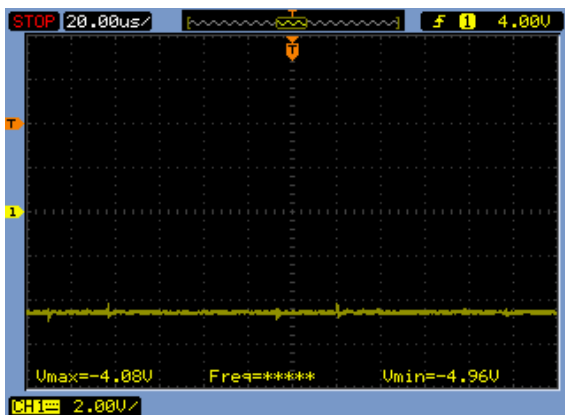

Fig. 15: Output  $V_{o2}$

From the Fig. 12 and Fig. 13 we can see that for an input voltage two output voltages are obtained which is of opposite polarity.

## VII. CONCLUSION

The high gain multiple output DC-DC converter is simulated using MATLAB/Simulink software. It is capable of producing three output voltages of 110 V, 19 V and -13 V for an input voltage of 5 V. One of the positive output voltage has a high gain of 20. The outputs voltage waveform obtained from simulation as shown in Fig. 7. From the figure it is clear that the ripple in output voltage is low. As the duty ratio is high the average value of stress is low and the instantaneous value is comparable with the output voltages. The hardware of dual output DC-DC converter is also done. The hardware results show that by a single input we can obtain two outputs of opposite polarity. Thus we can reduce the use of single input single output systems. By varying the duty ratio different output voltage levels can be obtained. This converter can be used for low power applications.

## VIII. REFERENCES

[1] A. Z. Rehman, I. Al-Bahadly, and S. Mukhopadhyay, "Multi input DC-DC converters in renewable energy applications: An overview", *Renewable and Sustainable Energy Reviews*, Vol. 41, pp. 521-539, 2015.

[2] A. Nami, F. Zare, A. Ghosh, and F. Blaabjerg, "Multi-output DC-DC converters based on diode clamped converters configuration: topology and control strategy", *2008 IET power electronics, 2010*, Vol. 3, pp. 197-208.

[3] R.-L. Lin, C.-R. Pan, and K.-H. Liu, "Family of single-inductor multi-output DCDC converter", *2008 International Conference on Power Electronics and Drive Systems, 2009*, pp. 1216-1221.

[4] K. Hwu, Y. Yau, and J.-J. Shieh, "Dual-output buck-boost converter with positive and negative output voltages under single positive voltage source fed", *International*

*Power Electronics Conference (IPEC)*, pp. 420-423, 2010.

[5] A. A. Boora, F. Zare, and A. Ghosh, "Multi-output buck-boost converter with enhanced dynamic response to load and input voltage changes", *IET Power Electronics*, Vol. 4, pp. 194-208, 2011

[6] M. R. Banaei, H. Ardi, R. Alizadeh, and A. Farakhor, "Non-isolated multi-input single-output DC/DC converter for photovoltaic power generation systems", *IET Power Electronics*, Vol. 7, pp. 2806- 2816, 2014.

[7] Divya Venugopal, Reshma Raj C, "Integrated Dual Output Buck Boost Converter for Industrial Application", *International Conference on Electrical, Electronics, and Optimization Techniques (ICEEOT)*, 2016.

[8] A. A. Boora, F. Zare, and A. Ghosh, "Multi-output buck boost converter with enhanced dynamic response to load and input voltage changes", *IET Power Electronics*, Vol. 4, pp. 194-208, 2011.

[9] Yajian Tong and Juri Jatskevich, "A Methodology to Derive Single-Stage Multiple Input Multiple-Output DC-DC Converters", *International Telecommunications Energy Conference*, 2014.

[10] Rong-Jong Wai and Kun-Huai Jheng, "High-Efficiency Single-Input Multiple Output DCDC Converter", *IEEE Transactions on Power Electronics*, Vol. 28, pp. 886-898, 2013.

[11] Yaser Nabati and Ebrahim Babaei, "A New DC-DC Converter with High Voltage Gain and Low Voltage Stress on Power Switches ", *IEEE Transactions on Power Electronics*, 2015.

[12] Jafar Marjani, Amir Imani, E. Afjei and A. Hekmani, "A New Dual Output DC-DC Converter with Enhancing Output Voltage Level", *24th Iranian Conference on Electrical Engineering*, 2016.