



# ANALYTICAL MODELING OF AlGaAs/GaAs VERTICAL CAVITY SURFACE EMITTING LASERS (VCSELS) OPERATING AT 850 nm FOR FREE-SPACE OPTICAL COMMUNICATION

Sanjeev Tyagi

Department of Electronics and Instrumentation Engg.  
MJP Rohilkhand University, Bareilly (UP) India

Sundar Singh

Department of Physics, Bareilly College, Bareilly  
(UP) India

**Abstract**— Analytical modeling of a Vertical Cavity Surface Emitting Laser (VCSEL) based on GaAs/AlGaAs material system has been presented in this paper. The VCSEL is expected to emit the laser radiation at 0.85  $\mu\text{m}$  wavelength which may be useful for free-space-optical communication (FSOC) through the available atmospheric window. The different properties of the VCSEL have been simulated analytically. The studies thus developed will provide useful design guidelines for the experimentalists for optimizing their device prototypes.

**Keywords**— Analytical modeling; DBR; FSOC; Vertical cavity surface-emitting laser

## I. INTRODUCTION

The free-space optical communication (FSOC) is favorite because of the availability of low loss atmospheric transmission windows in several spectral ranges [1]. The advantage of free-space optical communication includes high bandwidth, eye-safe, license-free operation, high transmission security, protocol transparency, jam-proof and error-free link. The FSOC consists of a light source and detector and uses the atmospheric windows as a medium of transmission. For FSOC it is necessary that the energy of the source should be in the form of a well-collimated beam in order to limit the large power loss between the source and detector [2]. As the light of a light source emitting diodes (LEDs) or LASERS have been used [2-4] but vertical-cavity surface-emitting lasers (VCSELS) are most suitable because of many inherent benefits like high-speed optical data communication capability and high modulation width at a low threshold current [5-6]. Moreover, VCSEL has several advantages over LEDs and edge-emitting sources because of its low divergence, high beam quality, circularly symmetric output beam, low-cost fabrication and packaging, and low power consumption. As light sources, high power VCSELS at the wavelength of 0.85  $\mu\text{m}$  have been developed for free-space-optical communication [7].

In this paper, we present analytical studies, which have been carried out for vertical-cavity surface-emitting laser (VCSEL) structure based on GaAs/AlGaAs material system [8]. The lattice constant of the GaAs/AlGaAs material system poorly depends on the mole fraction, so that it is possible to grow several lattice-matched epitaxial layers on GaAs substrate. Also an oxide of high aluminum concentration of AlGaAs can be formed to restrict the current in a VCSEL, gives very low threshold current and good optical confinement.

## II. THE PROPOSED STRUCTURE

A proposed structure of GaAs/AlGaAs VCSEL is shown in Fig.1 and it is identical to one reported by Jasim et al [9] The VCSEL structure consists of a 36-period- $\text{Al}_{0.16}\text{Ga}_{0.84}\text{As}/\text{Al}_{0.9}\text{Ga}_{0.1}\text{As}$  lower distributed Bragg reflector (DBR) with  $\lambda/4$  thickness, grown on the n-GaAs substrate. Then, the active region of GaAs quantum wells and  $\text{Al}_{0.24}\text{Ga}_{0.76}\text{As}$  barrier was sandwiched between two spacers of  $\text{Al}_{0.30}\text{Ga}_{0.70}\text{As}$ . The upper p-DBR consists of 20-period- $\text{Al}_{0.16}\text{Ga}_{0.84}\text{As}/\text{Al}_{0.9}\text{Ga}_{0.1}\text{As}$  with  $\lambda/4$  thickness. The VCSEL structure has been modeled analytically for its different characteristics.

## III. THE ANALYSIS

The Threshold current density is a key parameter in characterizing the diode laser performance where smaller values of threshold current density indicate superior performance. To achieve low threshold current density, the structure of the laser required short cavity length, high reflectivity and small thickness of the active region.

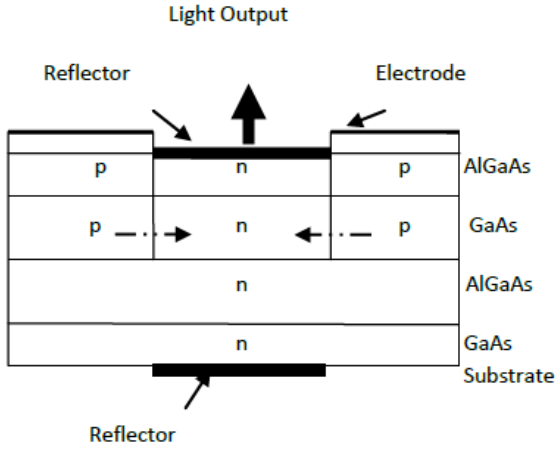

Fig.1 Schematic diagram of the proposed VCSEL

The relation between threshold current density, the thickness of the active region, cavity length and mirror reflectivities can be determined by examining the general condition for the laser in a Fabry-Perot cavity as follows:

$$R_1 R_2 \exp \left[ -j \frac{2\pi}{\lambda} (2nL) - j(\varphi_1 + \varphi_2) \right] \cdot \exp [2(\gamma - \alpha_i)] = 1 \quad (1)$$

Where  $\alpha_i$  is the total loss in the cavity,  $n$  is the refraction of the cavity medium,  $L$  is the effective length of the cavity,  $R_1, R_2$  are the reflectivity of two mirrors,  $\gamma$  is the gain and  $\varphi_1$  and  $\varphi_2$  are the phase shifts at mirrors.

From the amplitude condition for the surface-emitting laser, the general condition for the threshold of oscillation can be written as [8]

$$\Gamma \gamma_{th} d = \Gamma \alpha_a d + \alpha_c (L - d) + \ln \left( \frac{1}{\sqrt{R_1 R_2}} \right) \quad (2)$$

where  $\Gamma$  is the confinement factor,  $\Gamma = \Gamma_T \Gamma_L$  with transverse component  $\Gamma_T \approx 1$  and longitudinal component  $\Gamma_L = \frac{d}{L}$ ,  $d$  is the thickness of the region where the gain is distributed,  $\alpha_a$  is loss coefficient per unit length in the active region of the cavity;  $\alpha_c$  is the loss coefficient per unit length in the rest of the cavity.

The equation (2) can also be written as [8]

$$\gamma_{th} = \alpha_a + \frac{1}{\Gamma^2} \left[ \alpha_c (1 - \Gamma) + \frac{1}{L} \ln \left( \frac{1}{\sqrt{R_1 R_2}} \right) \right] \quad (3)$$

By solving the rate equation of lasers for steady-state condition, the threshold current density of oscillations can be written as

$$J_{th} = \frac{q d N_{th}}{\tau} \quad (4)$$

Where  $N_{th}$  is the threshold carrier density,  $q$  is the electronic charge and  $\tau$  is the spontaneous emission lifetime given by  $\tau = \frac{1}{B N_{th}}$ . Here  $B$  is the radiative recombination coefficient.

By taking account, the condition for continuous wave laser oscillation, the threshold carrier density  $N_{th}$  ( $N_{th} = \frac{\gamma_{th} + A N}{A}$ ) and spontaneous emission lifetime  $\tau$ , along with equation (3), the threshold current density ( $J_{th}$ ) can be estimated as [8]

$$J_{th} = \frac{q d B}{A^2} \left[ \alpha_a + A N + \frac{1}{\Gamma^2} \left\{ \alpha_c (1 - \Gamma) + \frac{1}{L} \ln \left( \frac{1}{\sqrt{R_1 R_2}} \right) \right\} \right]^2 \quad (5)$$

Equation (5) gives the dependence of threshold current density on the thickness of the active region, cavity length and mirror reflectivity of the proposed VCSEL.

**Table 1:** Values of various parameters used in the analytical study [8]

Parameter	Value( at 300K)
A	$4.0 \times 10^{-16} \text{cm}^2$
B	$1.0 \times 10^{-10} \text{cm}^3/\text{s}$
$\alpha_c$	$10 \text{cm}^{-1}$
$\alpha_a$	$25 \text{cm}^{-1}$
L	$15 \mu\text{m}$

#### IV. RESULTS AND DISCUSSION

The analytical studies have been performed on the proposed VCSEL based on GaAs/AlGaAs material system. The various materials parameters used in the study are given in Table 1.

Fig. 2 shows the dependence of the threshold current density of the proposed GaAs/AlGaAs VCSEL with the thickness of the active region for different mirror reflectivity at 300K. As a result of analytical studies, it is found that for low threshold current and short cavity length laser, the thickness of the active region should be small and the reflectivity of the corresponding mirror should be very high, of the order of 99%. However, to get the reflectivity of the order of 99.9% is the main hurdle to achieve the room temperature VCSEL operation based on GaAs/AlGaAs. Several DBR structures with better reflectivity have been reported in the recent past but the target reflectivity is yet to be reported. It is also clear from the graph that for low threshold VCSELs length of the cavity should be short at high reflectivity of the mirrors. However, short cavity lengths limit the output power of the VCSEL. So an optimum value of the cavity has to be taken for better VCSEL performance.

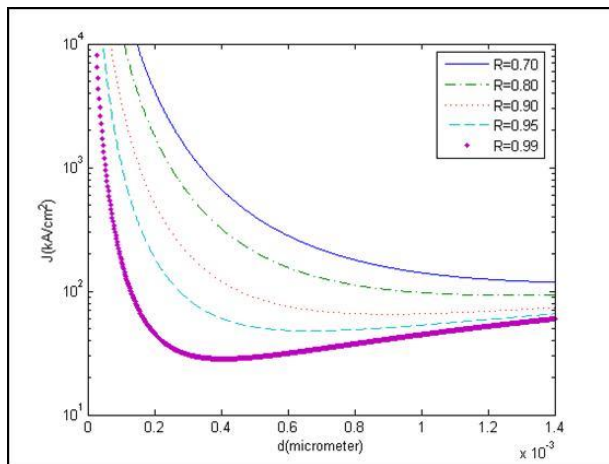

Fig. 2 Threshold current density (J) dependence on the thickness of the active region (d) at different mirror reflectivity of the proposed VCSEL.

The reflectivity spectrum of the  $\text{Al}_{0.16}\text{Ga}_{0.84}\text{As}/\text{Al}_{0.9}\text{Ga}_{0.1}\text{As}$  bottom DBR has been simulated for the proposed structure of GaAs/AlGaAs VCSEL by the transfer matrix method (TMM) using Matlab. Fig. 3. shows the plot of reflectivity vs. wavelength for the bottom DBR region for obtaining reflectivity of the order of 99% and above. Fig.2 shows the comparison between the peak power reflectivity of the bottom DBR estimated from theoretical and TMM analysis. It is clear from figures that approx. 30 numbers of periods are required for obtaining 99.9% reflectivity. So an optimum value of the number of periods for the DBR has to be chosen for better VCSEL performance.

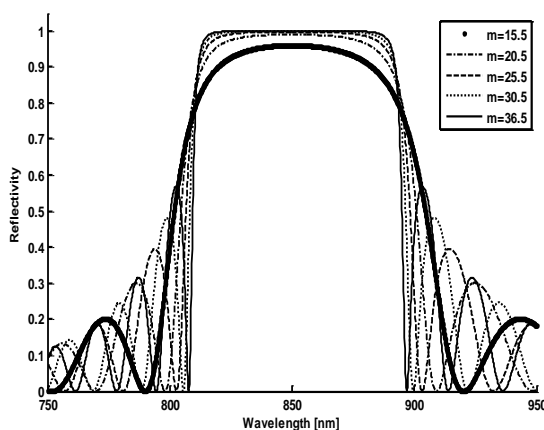

Figure 3. Reflectivity spectrum as a function of the wavelength of proposed VCSEL bottom DBR for different no. of periods.

Fig. 4 shows the plot of peak power reflectivity as a function of mirror pairs for  $\text{Al}_{0.16}\text{Ga}_{0.84}\text{As}/\text{Al}_{0.9}\text{Ga}_{0.1}\text{As}$  top and bottom DBRs of the VCSEL. From Fig.5 it is clear that the power reflectivity of the top mirror is higher than the bottom mirror for the same no. of periods. so greater no. of periods of  $\text{Al}_{0.16}\text{Ga}_{0.84}\text{As}/\text{Al}_{0.9}\text{Ga}_{0.1}\text{As}$  layers for bottom DBR is required for achieving reflectivity greater than 99.9% [9,10].

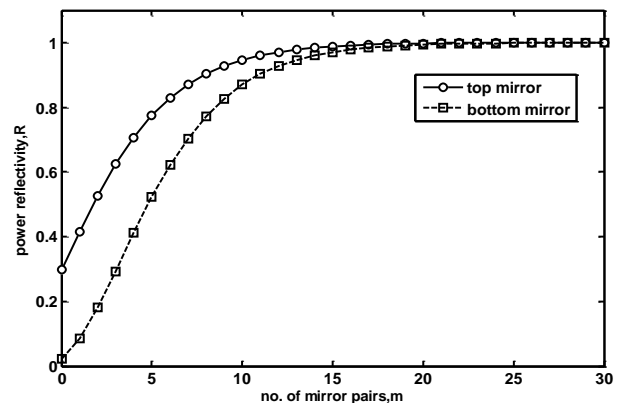

Fig. 4. The power reflectivity as a function of no. of mirrors pairs, m for  $\text{Al}_{0.16}\text{Ga}_{0.84}\text{As}/\text{Al}_{0.9}\text{Ga}_{0.1}\text{As}$  top and bottom DBR

## V. THE CONCLUSIONS

The AlGaAg/GaAs VCSEL has been simulated analytically for various optimizing parameters like threshold current density, cavity length, reflectivity spectrum and number of periods. It was observed that short cavity length, high reflectivity mirrors (of the order of 99%) and small thickness of the active region are required for low threshold VCSELs, which is still a challenge to achieve. The studies done in this paper may provide useful design guidelines to the experimentalists to optimize their laser structure for superior performance.

## VI. REFERENCE

- [1] N. S. Prasad, "Optical communication in the mid-wave IR spectral band," J. Opt. Fiber. Commun. Rep., 2, pp. 558-602, 2005.
- [2] [http://www.rp-photonics.com/free\\_space\\_optical\\_communications.html](http://www.rp-photonics.com/free_space_optical_communications.html) accessed on 02/01/2020.
- [3] [http://www.esa.int/esaCP/ESASGBZ84UC\\_index\\_0.html](http://www.esa.int/esaCP/ESASGBZ84UC_index_0.html) accessed on 02/01/2020
- [4] C. Hartmann and M. Pez, "High throughput free-space optical communication using white LED lighting equipment," Avionics, Fiber Optics and Photonics Technology, AVFOP'09. IEEE pp.78-79, 2009
- [5] W.W. Chow, K.D. Choquette, M.H. Crawford, K.L. Lear and G.R. Hadley, "Design, fabrication, and performance of infrared and visible vertical-cavity surface-emitting



- lasers,” *IEEE J Quantum Electron*, vol. 33(10), pp. 1810-1824, 1997.
- [6] H.H. Park, B.S. Yoo, “Low threshold current density and high-efficiency surface-emitting lasers with a periodic gain active structure,” *ETRI J*, vol. 17(1), pp. 1-10, 1995.
- [7] M. Yoshikawa, A. Murakami, J. Sakurai, H. Nakayama, T. Nakamura, “High power VCSEL devices for free-space optical communications,” *Electronics Components and Technology Conference*, vol. 2, pp 1353-1358, 2005.
- [8] E. Towe, F. Robert, and Y. Andrew, “A Historical Perspective of the development of the Vertical-cavity Surface-Emitting Laser.” *IEEE Journal on Selected Topics in Quantum Mechanics*, vol. 6(6), pp. 1458-1464, 2000
- [9] F. Z. Jasim, K. Omar, and Z. Hassan, “Temperature effect on VCSEL output performance,” *Optoelectronics and Advanced Materials-Rapid Communications*, vol. 3(11), pp. 1136-1138, 2009.
- [10] S. Tyagi and F. Parveen “Analytical Studies on Reflectance Spectrum of DBR of GaAs/AlGaAs VCSEL Operating at 0.85 $\mu\text{m}$ ,” *Journal of Basic and Applied Engineering Research*, vol.2 (3), p. 222, 2015