



# ENHANCED OPEN MONITORING ENVIRONMENT FOR CHILD (OMEC)

BALAVIGNESH S

Assistant Professor, Department of Electrical and Electronics,  
R.M.K. Engineering College, Tiruvallur, Chennai

PRIYA M.R, NIVEDHA.S, BHARGAVI.N

UG Scholar, Department of Electrical and Electronics Engineering,  
R.M.K. Engineering College, Tiruvallur, Chennai

**ABSTRACT:** *Nowadays the most common causes of death in children over years is due to playful activities which help to communicate, socialize and understand the surroundings. Falls; fires; scalds and burns; glass-related accidents; poisoning; suffocating and steps are the major factor which leads to babies accident. Even at this young age, new born are ready to learn about the world around them. But some time the play become tragedy and danger. Many accidents and harmful scenarios are happening while playing. Their mother has to monitor the children continuously to avoid the danger and problem occurring on the children. In our system child safety advice, the OMEC was implemented to avoid the children accidents and hazards. The wireless long way communication system enhanced to track the children location and the mother can get the alert about the children; the voice alert will be received by the mother. in case the children were reaching the dangerous zone, the siren system has been enhanced alert via the buzzer and the voice alert will be given to the mother.*

**Keywords:** *Children, Safety, Wearable, Voice alert.*

## I. INTRODUCTION

CHENNAI, India (Thomson Reuters Foundation) - At least 300,000 children across India are drugged, beaten and forced to beg every day, in what has become a multi-million rupee industry controlled by human trafficking cartels, police and trafficking experts said. Writing in a report which is about to be circulated across the country's police forces, the authors urged law enforcers to carry out greater surveillance of children living on the streets. Every year about 40,000 children are abducted in India of which atleast 11,000 remain untraced according to Indian National Human Rights Commission. "The police don't think begging is an issue because they assume that the adult with the child is either family or a known person," said co-author Anita Kanaiya, CEO of The Freedom Project India, which works on trafficking issues. "But for every 50 children rescued there will be at least 10 who are victims of trafficking. And there has to be a constant vigil to identify them," she told the

Thomson Reuters Foundation. Children are sometimes maimed or burned to elicit greater sympathy and get more alms, said the report. To avoid this kind of problem we proposed a new system. In Proposed System, the children's are monitored continuously using OMEC condition. Every time update about the children will be received and necessary action can be done by the mother. Here, the Wearable Wireless tracking system is adopted to check the location of children. In this system we are classifying the home into three locations in each location the wireless technology system has been implemented, that technology will communicate with the main child monitoring section and the location will be tracked using their communication. The GPS system is also implemented to identify the location in other area, by chance the child is going out of the home unit the location can be tracked. The location can be justified and GSM technology will send the location to mother's mobile according to the latitude and longitude. In mother's mobile the voice alert will be given via mobile application to know the location of the child. Whenever, the child is reaching the dangerous zone, the location is tracked and the monitoring unit will alert the mother using siren system. Heart beat sensor is used to detect body pulse rate, the sensor will detect the pulse of the body, once the child wearable devices is detached from the children body, and automatically it will alert the mothers via buzzer. Also, Voice alert will be received by the mother to take necessary action. In case the child is hiding in any critical spot the indication light is used to detect the location of the child, the child wearable device will have the dark indication light by giving the command on the mobile application the dark indication light will glow, so that we can spot the children easily.

## II. EXISTING SYSTEM

The existing system focuses on transmitting child's information via SMS text and enable communication between parent and the child. The wearable device will provide child's location,



temperature, UV radiation to the parent on receiving the keywords such as “LOCATION”, “TEMPERATURE”, “UV”, “SOS”, “BUZZER” respectively. In case of failure of any primary components the SOS light is used as secondary measure. The existing product is in the form of Wristband Vital which senses hazardous surroundings of children and seniors.

**A. PROBLEMS IN EXISTING SYSTEM:**

Children location cannot be monitored continuously. Detachment of wearable device cannot be identified. The signal is given to mother through Short Message Service (SMS) and since most of us won't read the message, it will create a problem. Simple buzzer alert has been adopted. One of the major drawback of Vital band is that it uses Bluetooth as a mode of communication which won't be able to establish a close link between the child and parent.

**III. PROPOSED SYSTEM A. SYSTEM OVERVIEW:**

In Proposed System, the children are monitored continuously using OMEC condition. Every time update about the children will be received and necessary action can be done by the mother. Here, the Wearable Wireless tracking system is adopted to check the location of children. In this system we are classifying the home into three locations in each location the wireless technology system has been implemented, that technology will communicate with the main child monitoring section and the location will be tracked using their communication. The GPS system is also implemented to identify the location in other area, by chance the child is going out of the home unit the location can be tracked. The location can be justified and GSM technology will send the location to mothers mobile according to the latitude and longitude. In mothers mobile the voice alert will be given via mobile application to know the location of the child. Whenever, the child is reaching the dangerous zone, the location is tracked and the monitoring unit will alert the mother using siren system. Heart beat sensor is used to detect body pulse rate, the sensor will detect the pulse of the body, once the child wearable devices is detached from the children body, and automatically it will alert the mothers via buzzer. Also, Voice alert will be received by the mother to take necessary action. In case the child is hiding in any critical spot the indication light is used to detect the location of the child, the child wearable device will have the dark indication light by giving the command on the mobile application the dark indication light will glow, so that we can spot the children easily.

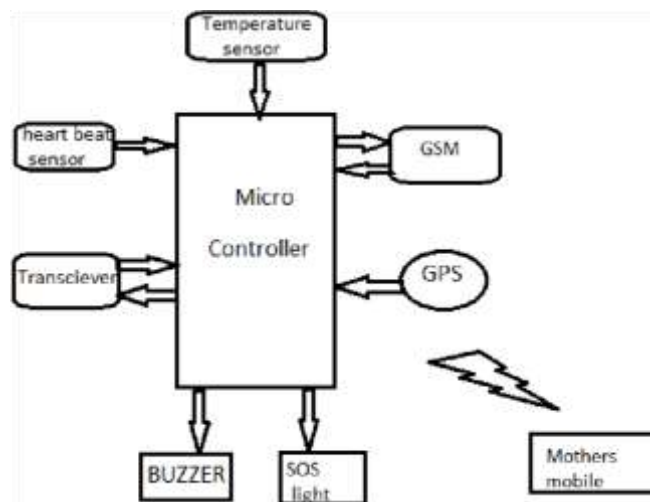

I. Fig 1. .Block diagram of children watch module.

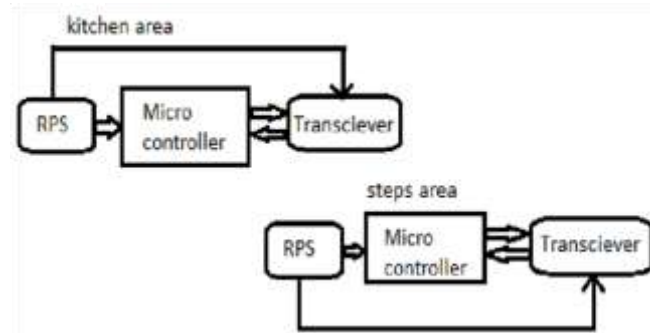

II. Fig 2. Block diagram of Home Unit

**B. HARDWARE COMPONENTS:**

The hardware components of the proposed system are:

- RPS-(REGULATED POWER SUPPLY)
- Microcontroller
- Wireless Transceiver
- Buzzer
- GSM
- GPS
- Heart Beat Sensor
- Temperature Sensor
- Indication Light

**1) PIC MICROCONTROLLER:**

Peripheral interface controller (PIC) microcontroller chip which is the world's smallest microcontroller designed for embedded. It



6. *GPS (GLOBAL POSITIONING SYSTEM):*

The GPS (Global Positioning System) is a “constellation” of approximately 30 well-spaced satellites that orbit the Earth and make it possible for people with ground receivers to pinpoint their geographic location. The location accuracy is anywhere from 100 to 10 meters for most equipment. Accuracy can be pinpointed to within one meter with special military-approved equipment. GPS equipment is widely used in science and has now become sufficiently low-cost so that almost anyone can own a GPS receiver.



Fig 5. GPS module

7. *GSM (GLOBAL SYSTEM FOR MOBILE COMMUNICATION):*

Global System for Mobile Communication is recognised as a standard for digital cellular communication globally. GSM is a cellular network which connects to the cell phones which is registered. The GSM module used in this project is SIM900. AMR926EJ-S processor present in the module is the one which controls phone communication, data communication and the communication with the circuit interfaced with the cell phone itself. The module also has a SIM card holder where the SIM can be attached. A continuous energy (between 3.4 and 4.5 V) is supplied and absorbs a maximum of 0.8 A during transmission.



Fig 6. SIM900

8. *BUZZER:*

A buzzer or beeper is an audio signalling device which finds application in alarm devices, timers, and confirmation of user input. The buzzer has

piezoelectric module which is responsible for high tone when the output is high. The working voltage is 5V. If the child is lost, the parent can locate the child by the loud sound produced by the buzzer. It can also acts as SOS signal to the people nearby that the child must be lost or in need of help.



Fig 6. Buzzer

9. *SOS LIGHT:*

The SOS light is used to alert the people nearby that the child might be in distress since the light will be flashing the universal SOS light symbol which many people nowadays know for to be a sign for help. The principal of SOS light is Morse code in which "S" stands for three short dots and the "O" stands for three long dashes.

*C. SOFTWARE COMPONENT*

The software components used are CCS compiler, ECLIPSE and POTEUS 7.0.

*1. CCS COMPILER:*

It is Built in libraries that work with all chips for RS232 serial I/O, I2C, discrete I/O and precision delays. Source level debugging is done by integrating with MPLAB IDE and other simulators and editors. Standard HEX file and debug files ensure compatibility with all programmers. Easy formatting and display in HEX or decimal is allowed by Formatted printf. Implementation of function efficiently allows call trees deeper than the hardware stack. Access to hardware features from easy t C functions, timers, A/D, EEPROM, SSP, PSP, USB, I2C and moreIt has 1, 8, 16 and 32 bit integer types and 32 bit floating point. Assembly code may be inserted anywhere in the source and may reference C variables. Multiple code pages is handled by automatic linking.

*2. ECLIPSE*

Eclipse is used as an integrated development environment (IDE) in computer programming. It is the most widely used Java IDE. Customization of environment is done using a base workspace and an extensible plug-in system. Eclipse is written mostly in Java. It is primarily used for developing Java applications and it may also be used to develop applications in other including Ada, ABAP, C, C++, C#, COBOL, D, Fortran, Haskell, JavaScript, Julia, Lasso, Lua, NATURAL, Perl, PHP, Prolog, Python, R, Ruby Rust, Scala, Clojure, Groovy, Scheme, and



Erlang.It can also be used to develop documents with LaTeX (via a TeXlipse plug-in) and packages for the software Mathematica.

### 3. PROTEUS 7.0 SIMULATION TOOL:

Proteus 7.0 is a Virtual System Modelling (VSM) that co-simulates complete microcontroller design by combining circuit simulation, animated components and microprocessor models. It act as a perfect tool for engineers to test their microcontroller designs before constructing a physical prototype in real time.

## IV. CONCLUSION

This project gives a new intelligent child security system that will be helpful to the parents in any helpless situations. It continuously monitors the sensor modules, if there any problem occurs, it will send information and location to the corresponding authorized parents. This system will work automatically so we can increase the child security. The violence against child tracking is avoided by this security system. Immediate information can be provided to parents

## V. REFERENCES

- [1] B. Dorsemaine, I. P. Gaulier, I. P. Wary, N. Kheir and P. Urien, "Internet of Things: A Definition and Taxonomy," *Next Generation Mobile Applications, Services and Technologies, 2015 9th International Conference on, Cambridge, 2015*, pp. 72- 77.
- [2] H. Moustafa, H. Kenn, K. Sayrafian, W. Scanlon and Y. Zhang, "Mobile wearable communications [Guest Editorial]," in *IEEE Wireless Communications*, vol. 22, no. 1, pp. 10-11, February 2015.
- [3] S. Nasrin and P. I. Radcliffe, "Novel protocol enables DIY home automation," *Telecommunication Networks and Applications Conference (ATNAC), 2014 Australasian, Southbank, VIC, 2014*, pp. 212-216.
- [4] F. A. Silva, "Industrial Wireless Sensor Networks: Applications, Protocols, and Standards [Book News]," in *IEEE Industrial Electronics Magazine*, vol. 8, no. 4, pp. 67-68, Dec. 2014.
- [5] Jun Zheng; Simplot-Ryl, D.; Bisdikian, c.; Mouftah, H.T., "The internet of things [Guest Editorial]," in *Communications Magazine, IEEE* , vol.49, no.11, pp.30-31, November 2011 doi: 10.1109/MCOM.2011.6069706

[6] K. Braam, Tsung-Ching Huang, Chin-Hui Chen, E. Montgomery, S. Vo and R. Beausoleil, "Wristband Vital: A wearable multi-sensor microsystem for real-time assistance via low-power Bluetooth link," *Internet of Things (WF-IoT), 2015 IEEE 2nd World Forwn on, Milan, 2015*, pp. 87-91. doi: 10.1109/WF-IoT.2015.7389032

[7] "Digital parenting: The best wearables and new smart baby monitors. The latest smart baby monitors and connected tech for your peace of mind," *Tech. Rep.*, 2015. [Online]. Available: <http://www.wearable.com/parenting/the-best-wearab-lesbabies-smart-baby-monitors>.

[8] "WiFi and WiMAX - break through in wireless access technologies," *Wireless, Mobile and Multimedia Networks, 2008. IET International Conference on, Beijing, 2008*, pp. 141- 145.

[9] P. Bhagwat, "Bluetooth: technology for shortrange wireless apps," in *IEEE Internet Computing*, vol. 5, no. 3, pp. 96-103, May/Jun 2001.